



HANDBOOK

## Redbox User Handbook No 4

**RB-DA6** 6 Way Stereo Distribution Amplifier  
**RB-DA6G** 6 Way Stereo Distribution Amplifier  
With Output Gain Control  
**RB-DA6P** 6 Way Stereo Distribution Amplifier  
**RB-DA6R** 6 Way Stereo Distribution Amplifier  
With RJ-45 Outputs  
**RB-DA6RG** 6 Way Stereo Distribution  
Amplifier With RJ-45 Outputs  
**RB-DA4x5** 4 Input, 4 x 5 Output Distribution  
Amplifier/Mixer  
**RB-DA24MD** 24 Way Mono Audio  
Distribution Amplifier  
**RB-DDA6A** 6 Way Stereo AES/EBU Digital  
Distribution Amplifier  
**RB-DDA6A3** 6 Way Stereo AES3 Digital Audio  
Distribution Amplifier

**RB-DDA6S** 6 Way Stereo S/PDIF Digital Distribution  
Amplifier  
**RB-DDA6A-2P** 6 Way Stereo AES/EBU Digital  
Distribution Amplifier With Dual Power Supplies  
**RB-DDA6W** 6 Way Word Clock Distribution Amplifier  
**RB-DDA6W-2P** 6 Way Word Clock Distribution Amplifier  
With Dual Power Supplies  
**RB-DDA22** Digital Audio Distribution Amplifier With  
Multiple Outputs  
**RB-AES4B3** Quad 3 Way Passive AES3ID Splitters With  
BNC Connectors  
**RB-AES4X3** Quad 3 Way AES3 Splitter XLR Connectors  
**RB-MS4X3** Quad 3 Way Microphone Splitter  
**RB-MSP6** 6 Way +48V Phantom Power Supply



Manufacturers of audio & video  
products for radio & TV broadcasters

**SONIFEX**

For the latest Sonifex handbook information please visit the  
Sonifex website at [www.sonifex.co.uk](http://www.sonifex.co.uk)

Redbox User Handbook No 4  
Stock Code: 30-341  
Artwork: AW10834A

Revision 3.01, December 2017  
©Sonifex Ltd, 2017  
All Rights Reserved

Sonifex Ltd, 61, Station Road, Irthlingborough,  
Northants, NN9 5QE, England.  
Tel: +44 (0)1933 650 700  
Fax: +44 (0)1933 650 726  
Email: [sales@sonifex.co.uk](mailto:sales@sonifex.co.uk)  
Website: <http://www.sonifex.co.uk>

Information in this document is subject to change without notice and does not represent a commitment on the part of the vendor. Sonifex Ltd shall not be liable for any loss or damage whatsoever arising from the use of information or any error contained in this manual.

No part of this manual may be reproduced or transmitted in any form or by any means, electronic or mechanical, including photocopying, recording, information storage and retrieval systems, for any purpose other than the purchaser's personal use, without the express written permission of Sonifex Ltd. Unless otherwise noted, all names of companies, products and persons contained herein are part of a completely fictitious adaptation and are designed solely to document the use of Sonifex product.

Made in the UK by **SONIFEX**

# Contents

## Product Warranty - 2 Year Extended

### Sonifex Warranty & Liability Terms & Conditions

1. Definitions
2. Warranty

### Unpacking Your Product

### Repairs & Returns

## ☞ Conformity

## Safety & Installation of Mains Operated Equipment

### Voltage Setting Checks

### Fuse Rating

### Power Cable & Connection

### WEEE Directive

### Atmosphere/Environment

### Fitting Redboxes

## 1 RB-DA6 6 Way Stereo Distribution Amplifier

### Introduction

System Block Diagram

### Connections and Operation

### Technical Specifications RB-DA6

## 2 RB-DA6G 6 Way Stereo Distribution Amplifier With Output Gain Control

### Introduction

System Block Diagram

### Connections and Operation

### Technical Specifications RB-DA6G

## 3 RB-DA6P 6 Way Stereo Distribution Amplifier

### Introduction

System Block Diagram

### Connections and Operation

### Technical Specifications RB-DA6P

## 4 RB-DA6R 6 Way Stereo Distribution Amplifier With RJ45 Outputs

### Introduction

### Connections and Operation

System Block Diagram

### Technical Specification RB-DA6R

## 5 RB-DA6RG 6 Way Stereo Distribution Amplifier With RJ45 Outputs

### Introduction

ii

ii

ii

ii

iii

iv

iv

iv

iv

iv

iv

v

v

v

1

1

1

2

3

4

4

4

5

6

7

7

7

7

8

9

9

10

10

11

11

13

14

14

## Connections and Operation

System Block Diagram

## Technical Specification RB-DA6RG

## 6 RB-DA4x5 4 Input, 4 x 5 Output Distribution Amplifier/Mixer

### Introduction

System Block Diagram

### Rear Panel Connections and Operation

## Technical Specifications RB-DA4x5

## 7 RB-DA24MD 24 Way Mono Audio Distribution Amplifier

### Introduction

### Connections And Operation

### Technical Specifications RB-DA24MD

## 8 RB-DDA6A 6 Way Stereo AES/EBU Digital Distribution Amplifier

### Introduction

### Rear Panel Connections and Operations

System Block Diagram

### Technical Specifications RB-DDA6A

## 9 RB-DDA6A-2P 6 Way Stereo AES/EBU Digital Distribution Amplifier With Dual Power Supplies

### Introduction

System Block Diagram

### Rear Panel Connections and Operations

## 10 RB-DDA6A3 6 Way Stereo AES-3id Digital Audio Distribution Amplifier

### Introduction

### Rear Panel Connections and Operations

System Block Diagram

### Technical Specifications RB-DDA6A3

## 11 RB-DDA6S 6 Way Stereo S/PDIF Digital Distribution Amplifier

### Introduction

### Rear Panel Connections and Operations

System Block Diagram

### Technical Specifications RB-DDA6S

## 12 RB-DDA6W 6 Way Word Clock Distribution Amplifier

### Introduction

### Rear Panel Connections and Operations

System Block Diagram

15

15

17

18

18

19

19

21

22

22

23

25

26

26

26

27

28

29

29

30

31

33

33

33

34

35

36

36

36

37

38

38

39

39

39

40

Technical Specifications RB-DDA6W	41
<b>13 RB-DDA6W-2P 6 Way Word Clock Distribution Amplifier With Dual Power Supplies</b>	<b>42</b>
Introduction	42
System Block Diagram	43
Rear Panel Connections and Operations	44
Technical Specification For RB-DDA6W-2P	45
<b>14 RB-DDA22 Digital Audio Distribution Amplifier With Multiple Outputs</b>	<b>46</b>
Introduction	46
System Block Diagram	47
Rear Panel Connections and Operations	48
Digital Audio Inputs	48
Digital Audio Outputs	48
Technical Specifications RB-DDA22	49
<b>15 RB-AES4B3 Quad 3 Way Passive AES-3id Splitters With BNC Connectors</b>	<b>50</b>
Introduction	50
Block Diagram	50
Controls & Connectors	51
Technical Specification RB-AES4B3	52
<b>16 RB-AES4X3 Quad 3 Way AES3 Splitter XLR Connectors</b>	<b>53</b>
Introduction	53
Block Diagram	53
Controls & Connectors	54
Technical Specifications RB-AES4X3	55
<b>17 RB-MS4X3 Quad 3 Way Microphone Splitter</b>	<b>56</b>
Introduction	56
Block Diagram	56
Controls & Connectors	57
Front Panel	57
Rear Panel	58
Technical Specifications RB-MS4X3	59
<b>18 RB-MSP6 6 Way +48V Phantom Power Supply</b>	<b>60</b>
Introduction	60
System Block Diagram	60
Connections and Operation	
Front Panel Controls and Indicators	61
Rear Panel Connections	61
Technical Specifications RB-MSP6	62

# Figures

Fig A: RB-RK1 Small Redbox Front Rack-mount Kit .	v	Fig 7-4: Analogue Input	23
Fig B: RB-RK2 Small Redbox Rear Rack-mount Kit.	vi	Fig 7-5: 25 Way D-Type Outputs	23
Fig C: RB-RK3 Large Redbox Rear Rack-mount Kit.	vi	Fig 7-6: 25 Roll Off and Dual Mono/Mixed Operation Switches	24
Fig 1-1: RB-DA6 Front Panel.	1	Fig 8-1: RB-DDA6A Front Panel	26
Fig 1-2: RB-DA6 System Block Diagram	1	Fig 8-2: RB-DDA6A Rear panel	26
Fig 1-3: RB-DA6 Rear Panel	2	Fig 8-3: RB-DDA6A System Block Diagram	27
Fig 2-1: RB-DA6G Front Panel	4	Fig 9-1: RB-DDA6A-2P Front Panel	29
Fig 2-2: RB-DA6G System Block Diagram	4	Fig 9-2: RB-DDA6A-2P System Block Diagram	30
Fig 2-3: RB-DA6G Rear Panel	5	Fig 9-3: RB-DDA6A-2P Rear panel	31
Fig 3-1: RB-DA6P Front Panel	7	Fig 9-4: RB-DDA6A-2P Alarm Connector Diagram	31
Fig 3-2: RB-DA6P System Block Diagram	7	Fig 10-1: RB-DDA6A3 Front Panel	33
Fig 3-3: RB-DA6P Rear Panel	8	Fig 10-2: RB-DDA6A3 Rear panel	33
Fig 3-4: RB-DA6P Phoenix Connectors	8	Fig 10-3: RB-DDA6A3 System Block Diagram	34
Fig 4-1: RB-DA6R Front Panel	10	Fig 11-1: RB-DDA6S Front Panel	36
Fig 4-2: RB-DA6R System Block Diagram	11	Fig 11-2: RB-DDA6S Rear panel	36
Fig 4-3: RB-DA6R Rear Panel	11	Fig 11-3: RB-DDA6S System Block Diagram	37
Fig 4-4: RB-DA6R Input Selector Switch	11	Fig 12-1: RB-DDA6W Front Panel	39
Fig 4-5: RB-DA6R Front Panel Input Gain Controls and Stereo/Mono Switch	12	Fig 12-2: RB-DDA6W Rear Panel	39
Fig 5-1: RB-DA6RG Front Panel	14	Fig 12-3: RB-DDA6W System Block Diagram	40
Fig 5-2: RB-DA6RG System Block Diagram	15	Fig 13-1: RB-DDA6W-2P Front Panel	42
Fig 5-3: RB-DA6RG Rear Panel	15	Fig 13-2: RB-DDA6W-2P System Block Diagram	43
Fig 5-4: RB-DA6RG Input Selector Switch	16	Fig 13-3: RB-DDA6W-2P Rear Panel	44
Fig 5-5: RB-DA6RG Front Panel Output Gain Controls and Stereo/Mono Switch	16	Fig 13-4: RB-DDA6W-2P Alarm Connector Diagram	44
Fig 6-1: RB-DA4x5 Front Panel	18	Fig 14-1: RB-DDA22 Front Panel	46
Fig 6-2: RB-DA4x5 System Block Diagram	19	Fig 14-2: RB-DDA22 Front Panel Controls	46
Fig 6-3: RB-DA4x5 Rear Panel	19	Fig 14-3: RB-DDA22 System Block Diagram	47
Fig 6-4: RB-DA4x5 Audio Output Group15-Way D-Type Plug	20	Fig 14-4: RB-DDA22 Rear Panel	48
Fig 6-5: RB-DA4x5 Pinout for Audio Output Group Connector	20	Fig 15-1: RB-AES4B3 Front Panel	50
Fig 6-6: RB-DA4x5 Routing Selection Switch	20	Fig 15-2: RB-AES4B3 System Block Diagram	50
Fig 6-7: RB-DA4x5 Routing Selection Switch Functions	20	Fig 15-3: RB-AES4B3 Front Rear Panel	51
Fig 7-1: RB-DA24MD Front Panel	22	Fig 15-4: RB-AES4B3 Examples Of Cumulative Cabling	52
Fig 7-2: RB-DA24MD System Block Diagram	22	Fig 16-1: RB-AES4X3 Front Panel	53
Fig 7-3: RB-DA24MD Rear Panel	23	Fig 16-2: RB-AES4X3 System Block Diagram	53
		Fig 16-3: RB-AES4X3 Rear Panel	54
		Fig 16-4: RB-AES4X3 Examples Of Cumulative Cabling	55

Fig 17-1: RB-MS4X3 Front Panel	56
Fig 17-2: RB-MS4X3 System Block Diagram	56
Fig 17-3: RB-MS4X3 Front Panel Connections	57
Fig 17-4: RB-MS4X3 Rear Panel Connections	58
Fig 17-5: RB-MS4X3 Examples Of Usage	59
Fig 18-1: RB-MSP6 Front Panel	60
Fig 18-2: RB-MSP6 System Block Diagram	60
Fig 18-3: RB-MSP6 Front Panel LED Indicators	61
Fig 18-4: RB-MSP6 Rear Panel Connections	61
Fig 18-5: RB-MSP6 Fault Scenario Diagram	62

# SONIFEX

## Register Online for an Extended 2 Year Warranty

As standard, Sonifex products are supplied with a 1 year back to base warranty.

If you register the product online, you can increase your product warranty to 2 years and we can also keep you informed of any product design improvements or modifications.

Product: \_\_\_\_\_

Serial No: \_\_\_\_\_

To register your product, please go online to [www.sonifex.co.uk/register](http://www.sonifex.co.uk/register)

## Product Warranty - 2 Year Extended

As standard, Sonifex products are supplied with a 1 year back to base warranty. In order to register the date of purchase and so that we can keep you informed of any product design improvements or modifications, it is important to complete the warranty registration online. Additionally, if you register the product on the Sonifex website, you can increase your product warranty to 2 years. Go to the Sonifex website at: <http://www.sonifex.co.uk/technical/register/index.asp> to apply for your 2 year warranty.

**Note:** For your own records the product serial number is recorded on the CE certification page of this handbook.

## Sonifex Warranty & Liability Terms & Conditions

### 1. Definitions

‘the Company’ means Sonifex Ltd and where relevant includes companies within the same group of companies as Sonifex Limited.

‘the Goods’ means the goods or any part thereof supplied by the Company and where relevant includes: work carried out by the Company on items supplied by the Purchaser; services supplied by the Company; and software supplied by the Company.

‘the Purchaser’ means the person or organisation who buys or has agreed to buy the Goods.

‘the Price’ means the Price of the Goods and any other charges incurred by the Company in the supply of the Goods.

‘the Warranty Term’ is the length of the product warranty which is usually 12 months from the date of despatch; except when the product has been registered at the Sonifex website when the Warranty Term is 24 months from the date of despatch.

‘the Contract’ means the quotation, these Conditions of Sale and any other document incorporated in a contract between the Company and the Purchaser.

This is the entire Contract between the parties relating to the subject matter hereof and may not be changed or terminated except in writing in accordance with the provisions of this Contract. A reference to the consent, acknowledgement, authority or agreement of the Company means in writing and only by a director of the Company.

### 2. Warranty

- a. The Company agrees to repair or (at its discretion) replace Goods which are found to be defective (fair wear and tear excepted) and which are returned to the Company within the Warranty Term provided that each of the following are satisfied:
  - i. notification of any defect is given to the Company immediately upon its becoming apparent to the Purchaser;
  - ii. the Goods have only been operated under normal operating conditions and have only been subject to normal use (and in particular the Goods must have been correctly connected and must not have been subject to high voltage or to ionising radiation and must not have been used contrary to the Company’s technical recommendations);
  - iii. the Goods are returned to the Company’s premises at the Purchaser’s expense;
  - iv. any Goods or parts of Goods replaced shall become the property of the Company;
  - v. no work whatsoever (other than normal and proper maintenance) has been carried out to the Goods or any part of the Goods without the Company’s prior written consent;

- vi. the defect has not arisen from a design made, furnished or specified by the Purchaser;
  - vii. the Goods have been assembled or incorporated into other goods only in accordance with any instructions issued by the Company;
  - viii. the defect has not arisen from a design modified by the Purchaser;
  - ix. the defect has not arisen from an item manufactured by a person other than the Company. In respect of any item manufactured by a person other than the Company, the Purchaser shall only be entitled to the benefit of any warranty or guarantee provided by such manufacturer to the Company.
- b. In respect of computer software supplied by the Company the Company does not warrant that the use of the software will be uninterrupted or error free.
- c. The Company accepts liability:
- (i) for death or personal injury to the extent that it results from the negligence of the Company, its employees (whilst in the course of their employment) or its agents (in the course of the agency);
  - (ii) for any breach by the Company of any statutory undertaking as to title, quiet possession and freedom from encumbrance.
- d. Subject to conditions (a) and (c) from the time of despatch of the Goods from the Company's premises the Purchaser shall be responsible for any defect in the Goods or loss, damage, nuisance or interference whatsoever consequential economic or otherwise or wastage of material resulting from or caused by or to the Goods. In particular the Company shall not be liable for any loss of profits or other economic losses. The Company accordingly excludes all liability for the same.
- e. At the request and expense of the Purchaser the Company will test the Goods to ascertain performance levels and provide a report of the results of that test. The report will be accurate at the time of the test, to the best of the belief and knowledge of the Company, and the Company accepts no liability in respect of its accuracy beyond that set out in Condition (a).
- f. Subject to Condition (e) no representation, condition, warranty or other term, express or implied (by statute or otherwise) is given by the Company that the Goods are of any particular quality or standard or will enable the Purchaser to attain any particular performance or result, or will be suitable for any particular purpose or use under specific conditions or will provide any particular capacity, notwithstanding that the requirement for such performance, result or capacity or that such particular purpose or conditions may have been known (or ought to have been known) to the Company, its employees or agents.
- g. (i) To the extent that the Company is held legally liable to the Purchaser for any single breach of contract, tort, representation or other act or default, the Company's liability for the same shall not exceed the price of the Goods.
- (ii) The restriction of liability in Condition (g)(i) shall not apply to any liability accepted by the Seller in Condition (c).
- h. Where the Goods are sold under a consumer transaction (as defined by the Consumer Transactions (Restrictions on Statements) Order 1976) the statutory rights of the Purchaser are not affected by these Conditions of Sale.

## Unpacking Your Product

Each product is shipped in protective packaging and should be inspected for damage before use. If there is any transit damage take pictures of the product packaging and notify the carrier immediately with all the relevant

details of the shipment. Packing materials should be kept for inspection and also for if the product needs to be returned.

The product is shipped with the following equipment so please check to ensure that you have all of the items below. If anything is missing, please contact the supplier of your equipment immediately.

Item	Quantity
Product unit	1
IEC mains lead fitted with moulded mains plug	1
Handbook and warranty card	1

If you require a different power lead, please let us know when ordering the product.

## Repairs & Returns

Please contact Sonifex or your supplier if you have any problems with your Sonifex product. Email [technical.support@sonifex.co.uk](mailto:technical.support@sonifex.co.uk) for the repair/upgrade/returns procedure, or for support & questions regarding the product operation.

## CE Conformity

The products in this manual comply with the essential requirements of the relevant European health, safety and environmental protection legislation.

The technical justification file for this product is available at Sonifex Ltd.

The declaration of conformity can be found at:  
<http://www.sonifex.co.uk/declarations>

## Safety & Installation of Mains Operated Equipment

There are no user serviceable parts inside the equipment. If you should ever need to look inside the unit, always disconnect the mains supply before removing the equipment covers. The cover is connected to earth by means of the fixing screws. It is essential to maintain this earth/ground connection to ensure a safe operating environment and provide electromagnetic shielding.

### Voltage Setting Checks

Ensure that the machine operating voltage is correct for your mains power supply by checking the box in which your product was supplied. The voltage is shown on the box label. The available voltage settings are 115V, or 230V. Please note that all products are either switchable between 115V and 230V, or have a universal power supply.

### Fuse Rating





The product is supplied with a single fuse in the live conducting path of the mains power input. For reasons of safety it is important that the correct rating and type of fuse is used. Incorrectly rated fuses could present a possible fire hazard, under equipment fault conditions. The active fuse is fitted on the outside rear panel of the unit.

### Power Cable & Connection

An IEC power connector is supplied with the product which has a moulded plug attached.

The mains plug or IEC power connector is used as the disconnect device. The mains plug and IEC power connector shall remain readily operable to disconnect the apparatus in case of a fault or emergency.

The mains lead is automatically configured for the country that the product is being sent to, from one of:

Territory	Voltage	IEC Lead Type	Image
UK & Middle East	230V	UK 3 pin to IEC lead	
Europe	230V	European Schuko round 2 pin to IEC lead	
USA, Canada and South America	115V	3 flat pin to IEC lead	
Australia & New Zealand	230V	Australasian 3 flat pin to IEC lead	

Connect the equipment in accordance with the connection details and before applying power to the unit, check that the machine has the correct operating voltage for your mains power supply.

This apparatus is of a class I construction. It must be connected to a mains socket outlet with a protective earthing connection.

**Important note:** If there is an earth/ground terminal on the rear panel of the product then it must be connected to Earth.



Fig A: RB-RK1 Small Redbox Front Rack-mount Kit .

## WEEE Directive



The Waste Electrical and Electronic Equipment (WEEE) Directive was agreed on 13 February 2003, along with the related Directive 2002/95/EC on Restrictions of the use of certain Hazardous Substances in electrical and electronic equipment (RoHS). The Waste Electrical and Electronic Equipment Directive (WEEE) aims to minimise the impacts of electrical and electronic equipment on the environment during their life times and when they become waste. All products manufactured by Sonifex Ltd have the WEEE directive label placed on the case. Sonifex Ltd will be happy to give you information about local organisations that can reprocess the product when it reaches its “end of use”, or alternatively all products that have reached “end of use” can be returned to Sonifex and will be reprocessed correctly free of charge.

## Atmosphere/Environment

This apparatus should be installed in an area that is not subject to excessive temperature variation (<0°C, >50°C), moisture, dust or vibration.

This apparatus shall not be exposed to dripping or splashing, and no objects filled with water, such as vases shall be placed on the apparatus.

## Fitting Redboxes

Redboxes can be fixed to the underside of a desk, or other surfaces using 4.2mm holes in the sides and fixed with 2 x M4 screws or 2 x No. 6 countersink wood screws.

They can also be rack-mounted, with either the front, or rear of the Redbox positioned at the front of the rack (Note: this product is front rack-mounted as standard):

**Front Mounting Redboxes:** For rack mounting smaller (28cm) units the optional **RB-RK1** (Red) or **RB-RK1B** (Black) kit can be used (which include 4 off M6 panel fixing screws).

**Rear Mounting a Redbox:** For rear panel mounting you can use either the **RB-RK2** (in this case), or **RB-RK3**, depending on the size of your Redbox.

**RK2**

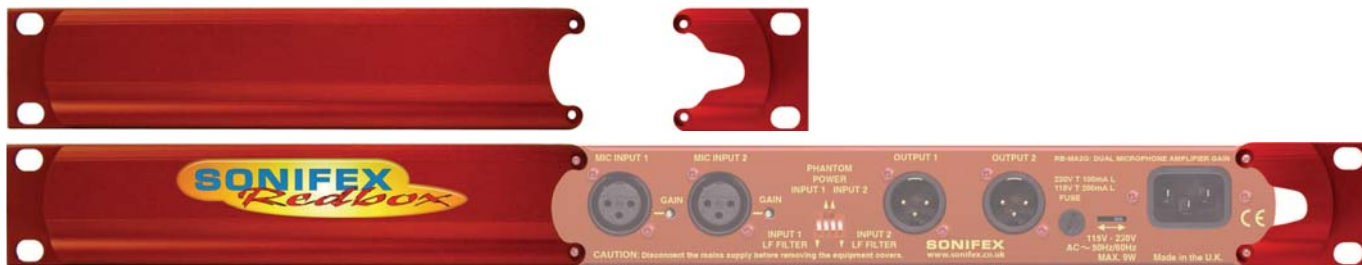

Fig B: RB-RK2 Small Redbox Rear Rack-mount Kit.

**RK3**



Fig C: RB-RK3 Large Redbox Rear Rack-mount Kit.

# 1 RB-DA6 6 Way Stereo Distribution Amplifier

## Introduction



Fig 1-1: RB-DA6 Front Panel.

The RB-DA6 is a high performance 6 way stereo analogue distribution amplifier for splitting a source to a number of different outputs. The RB-DA6 has 1 stereo input and 6 stereo outputs with gain control on both inputs. It can also be configured so that 1 mono input can be distributed to 12 outputs.

The XLR-3 inputs and outputs are electronically balanced and can be wired unbalanced. Each output is individually buffered so that a short circuit on one won't affect the others.

The RB-DA6 has master left and right gain controls which are pre-set potentiometers accessible through the front panel.

## System Block Diagram

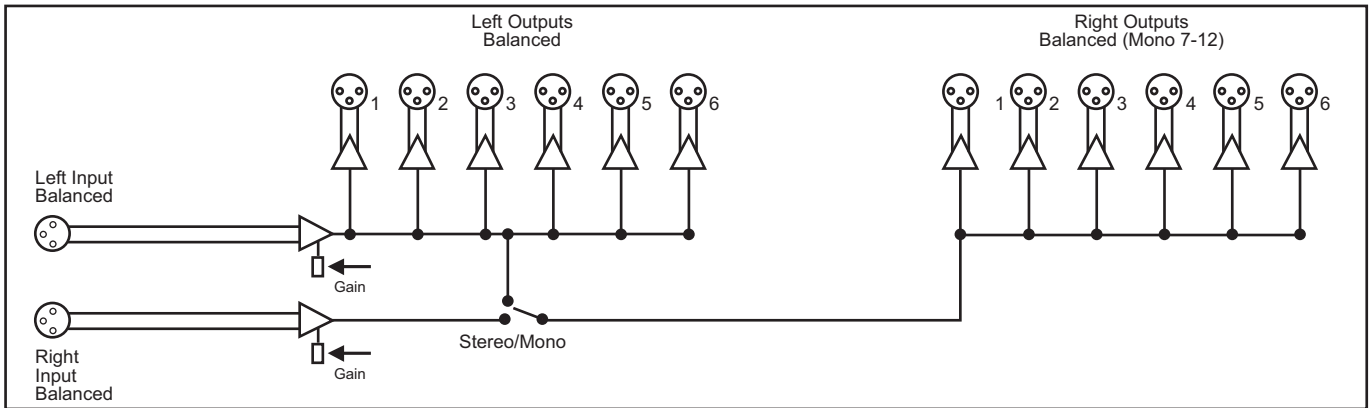

Fig 1-2: RB-DA6 System Block Diagram

## Connections and Operation

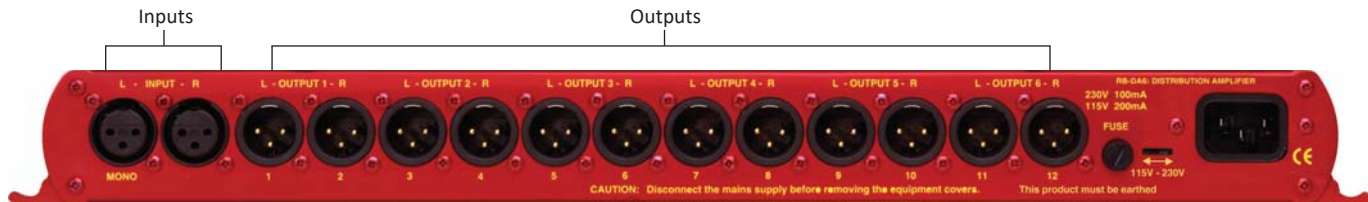

Fig 1-3: RB-DA6 Rear Panel

### Inputs (Left and Right)

The XLR-3 input connectors can take balanced professional levels, or unbalanced by using the front panel gain controls, and by connecting the non-phase to the signal ground. The input can be configured as either a stereo input with six stereo outputs or a mono input with twelve outputs.

The XLR 3 pin input has the following connections:

- Pin 1: Screen
- Pin 2: Phase
- Pin 3: Non-phase

### Stereo Outputs 1-6 (Mono Outputs 1-12)

The XLR 3 pin outputs are electronically balanced, and can be wired unbalanced. Each output is individually buffered so that a short circuit on one output will not affect the others. They have the following connections:

- Pin 1: Screen
- Pin 2: Phase
- Pin 3: Non-phase

### Input Gain Control

The input gain on the RB-DA6 can be varied  $-8\text{dB}$  to  $18\text{dB}$  by adjusting the pre-set potentiometers. These are accessible through the holes in the front panel. The RB-DA6 has separate left and right master gain controls.

### Stereo/Mono Operation

The mode of operation may be switched between a stereo distributed channel to 6 stereo channels, and a mono channel to 12 mono channels, by the push button on the front panel, which is recessed to prevent accidental switching.

## Technical Specifications RB-DA6

### Audio Specifications

Input Impedance:	>20k $\Omega$ bridging
Output Impedance:	<50 $\Omega$
Maximum Input Level:	+28dBu
Maximum Output Level:	+28dBu
Frequency Response:	20Hz to 20kHz $\pm$ 0.1dB (600 $\Omega$ load, ref 1kHz)
Common Mode Rejection:	>66dB typically
Distortion:	0.01% THD @ 1kHz, ref +8dBu output
Noise:	-100dB unity gain ref +8dB

### Connections

Inputs:	2 x 3 pin female (Balanced, can be unbalanced)
Outputs:	12 x XLR 3 pin male (Balanced, can be unbalanced)
Mains Input:	Filtered IEC, 110V-120V, or 220-240V, fused, 6W maximum
Fuse Rating:	Anti-surge fuse 100mA 20 x 5mm (230VAC) Anti-surge fuse 250mA 20 x 5mm (115VAC)

### Equipment Type

RB-DA6:		6 way stereo distribution amplifier
---------	--	-------------------------------------

### Physical Specifications

Dimensions (Raw):	48cm (W) x 10.8cm (D) x 4.2cm (H) (1U) 19" (W) x 4.3" (D) x 1.7" (H) (1U)
Dimensions (Boxed):	58.5cm (W) x 22.5cm (D) x 7cm (H) 21" (W) x 8" (D) x 2.4" (H)
Weight:	Nett: 1.3kg Gross: 1.9kg Nett: 2.9lbs Gross: 4.2lbs

## 2 RB-DA6G 6 Way Stereo Distribution Amplifier With Output Gain Control

### Introduction



Fig 2-1: RB-DA6G Front Panel

The RB-DA6G is a high performance 6 way stereo analogue distribution amplifier for splitting a source to a number of different outputs.

The RB-DA6P has 1 stereo input and 6 stereo outputs with gain control on both inputs. It can also be configured so that 1 mono input can be distributed to 12 outputs. As a variant of the RB-DA6, the RB-DA6G, has an individual gain control on every output.

On the RB-DA6G the XLR-3 inputs and outputs are electronically balanced and can be wired unbalanced. Each output is individually buffered so that a short circuit on one won't affect the others.

The RB-DA6G has master left and right gain controls which are pre-set potentiometers accessible through the front panel. Each channel has an individual output gain control (normalising) which are all pre-set potentiometers, also accessible through the front panel. The 1-12 mono, 1-6 stereo switch is recessed on the front panel to prevent accidental knocking. An LED power indicator on the front panel displays the power supply connection.

### System Block Diagram

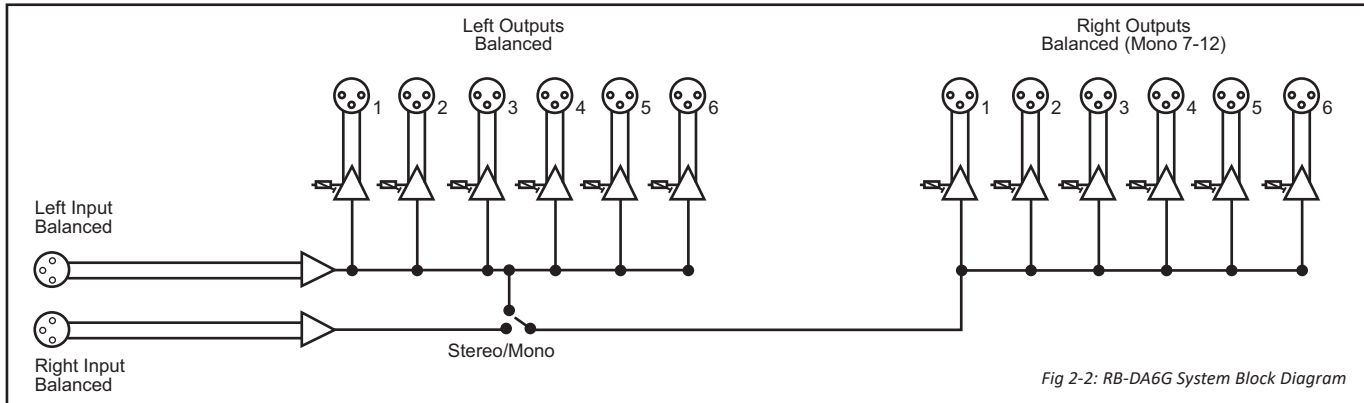

Fig 2-2: RB-DA6G System Block Diagram

## Connections and Operation

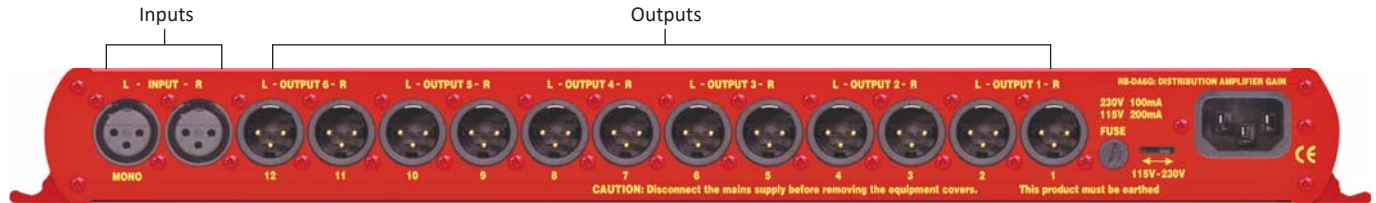

Fig 2-3: RB-DA6G Rear Panel

### Inputs (Left and Right)

The XLR-3 input connectors can take balanced professional levels, or unbalanced by using the front panel gain controls, and by connecting the non-phase to the signal ground. The input can be configured as either a stereo input with six stereo outputs or a mono input with twelve outputs.

The XLR 3 pin input has the following connections:

- Pin 1: Screen
- Pin 2: Phase
- Pin 3: Non-phase

### Stereo Outputs 1-6 (Mono Outputs 1-12)

The XLR 3 pin outputs are electronically balanced, and can be wired unbalanced. Each output is individually buffered so that a short circuit on one output will not affect the others. They have the following connections:

- Pin 1: Screen
- Pin 2: Phase
- Pin 3: Non-phase

### Output Gain Control

The output gain on the RB-DA6G can be varied  $-8\text{dB}$  to  $18\text{dB}$  by adjusting the pre-set potentiometers. These are accessible through the holes in the front panel. The RB-DA6G has output gain controls on every output.

### Stereo/Mono Operation

The mode of operation may be switched between a stereo distributed channel to 6 stereo channels, and a mono channel to 12 mono channels, by the push button on the front panel, which is recessed to prevent accidental switching.

## Technical Specifications RB-DA6G

### Audio Specifications

Input Impedance:	>20kΩ bridging
Output Impedance:	<50Ω
Maximum Input Level:	+28dBu
Maximum Output Level:	+28dBu
Frequency Response:	20Hz to 20kHz ± 0.1dB (600Ω load, ref 1kHz)
Gain Range:	Adjustable 8dB loss to 18dB gain
Common Mode Rejection:	>66dB typically
Distortion:	0.01% THD @ 1kHz, ref +8dBu output
Noise:	-88dB unity gain ref +8dB

### Connections

Inputs:	2 x 3 pin female (Balanced, can be unbalanced)
Outputs:	12 x XLR 3 pin male (Balanced, can be unbalanced)
Mains Input:	Filtered IEC, 110V-120V, or 220-240V, fused, 6W maximum
Fuse Rating:	Anti-surge fuse 100mA 20 x 5mm (230VAC) Anti-surge fuse 250mA 20 x 5mm (115VAC)

### Equipment Type

RB-DA6G:		6 way stereo distribution amplifier with output gain
----------	---	--

### Physical Specifications

Dimensions (Raw):	48cm (W) x 10.8cm (D) x 4.2cm (H) (1U) 19" (W) x 4.3" (D) x 1.7" (H) (1U)
Dimensions (Boxed):	58.5cm (W) x 22.5cm (D) x 7cm (H) 21" (W) x 8" (D) x 2.4" (H)
Weight:	Nett: 1.3kg Gross: 1.9kg Nett: 2.9lbs Gross: 4.2lbs

## 3 RB-DA6P 6 Way Stereo Distribution Amplifier

### Introduction



Fig 3-1: RB-DA6P Front Panel

The RB-DA6P is a high performance 6 way stereo analogue distribution amplifier for splitting a source to a number of different outputs. The RB-DA6P has 1 stereo input and 6 stereo outputs with gain control on both inputs. It can also be configured so that 1 mono input can be distributed to 12 outputs.

The RB-DA6P is a version of the RB-DA6 audio distribution amplifier which uses Neutrik Phoenix style connectors instead of XLR inputs and outputs. Each unit is shipped with the mating connectors so that wires can be simply

terminated using a small flat-blade screwdriver. The inputs and outputs are electronically balanced and can be wired unbalanced. Each output is individually buffered so that a short circuit on one won't affect the others.

It has master left and right gain controls which are pre-set potentiometers accessible through the front panel.

### System Block Diagram

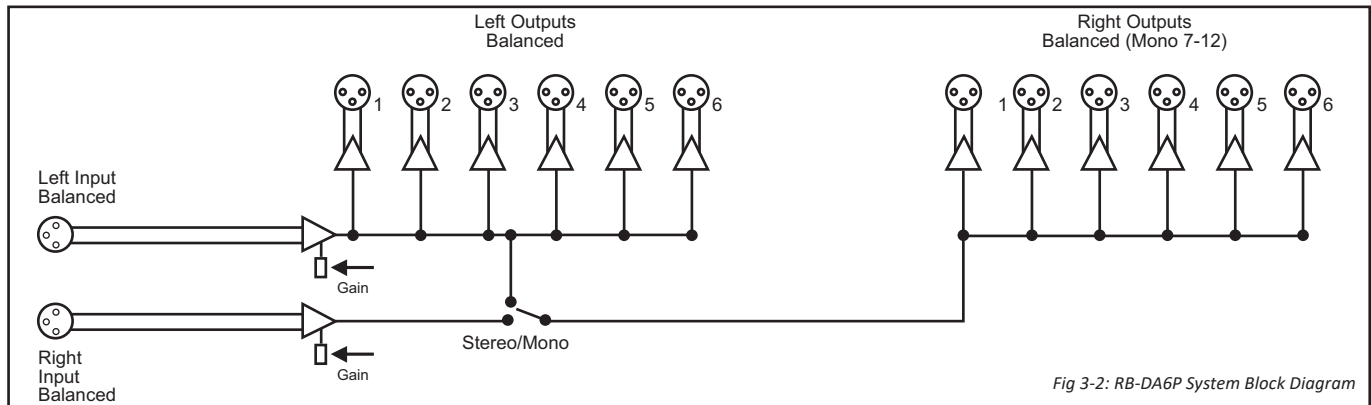

Fig 3-2: RB-DA6P System Block Diagram

## Connections and Operation

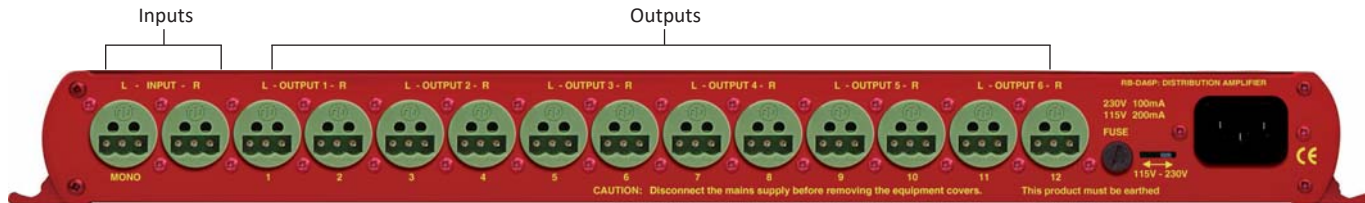

Fig 3-3: RB-DA6P Rear Panel

### Inputs (Left and Right)

The Phoenix style input connectors can take balanced professional levels, or unbalanced by using the front panel gain controls, and by connecting the non-phase to the signal ground. The input can be configured as either a stereo input with six stereo outputs or a mono input with twelve outputs. The connections are shown in Fig 1-8.

### Stereo Outputs 1-6 (Mono Outputs 1-12)

The Phoenix style 3 pin outputs are electronically balanced, and can be wired unbalanced. Each output is individually buffered so that a short circuit on one output will not affect the others. The connections are shown in Fig 3-4.

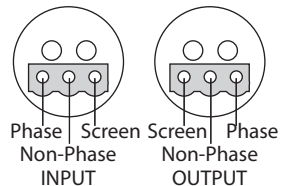

Fig 3-4: RB-DA6P Phoenix Connectors

### Input Gain Control

The input gain on the RB-DA6 can be varied  $-8\text{dB}$  to  $18\text{dB}$  by adjusting the pre-set potentiometers. These are accessible through the holes in the front panel. The RB-DA6 has separate left and right master gain controls.

### Stereo/Mono Operation

The mode of operation may be switched between a stereo distributed channel to 6 stereo channels, and a mono channel to 12 mono channels, by the push button on the front panel, which is recessed to prevent accidental switching.

## Technical Specifications RB-DA6P

### Audio Specifications

Input Impedance:	>20k $\Omega$ bridging
Output Impedance:	<50 $\Omega$
Maximum Input Level:	+28dBu
Maximum Output Level:	+28dBu
Frequency Response:	20Hz to 20kHz $\pm$ 0.1dB (600 $\Omega$ load, ref 1kHz)
Gain Range:	Adjustable 8dB loss to 18dB gain
Common Mode Rejection:	>66dB typically
Distortion:	0.01% THD @ 1kHz, ref +8dBu output
Noise:	-100dB unity gain ref +8dB (RB-DA6)

### Connections

Inputs:	2 x Phoenix 3 pin female (Balanced, can be unbalanced)
Outputs:	12 x Phoenix 3 pin male (Balanced, can be unbalanced)
Mains Input:	Filtered IEC, 110V-120V, or 220-240V, fused, 6W maximum
Fuse Rating:	Anti-surge fuse 100mA 20 x 5mm (230VAC) Anti-surge fuse 250mA 20 x 5mm (115VAC)

### Equipment Type

RB-DA6P:		6 way stereo distribution amplifier with Phoenix connectors
----------	--	---

### Physical Specifications

Dimensions (Raw):	48cm (W) x 10.8cm (D) x 4.2cm (H) (1U) 19" (W) x 4.3" (D) x 1.7" (H) (1U)
Dimensions (Boxed):	58.5cm (W) x 22.5cm (D) x 7cm (H) 21" (W) x 8" (D) x 2.4" (H)
Weight:	Nett: 1.3kg    Gross: 1.9kg Nett: 2.9lbs    Gross: 4.2lbs

## 4 RB-DA6R 6 Way Stereo Distribution Amplifier With RJ45 Outputs

### Introduction



Fig 4-1: RB-DA6R Front Panel

The RB-DA6R is a high performance 6 way stereo analogue distribution amplifiers for splitting a source to a number of different outputs. The RB-DA6R has 1 stereo input and 6 stereo outputs with gain control on both inputs. It can also be configured so that 1 mono input is distributed to 12 outputs.

A rear panel mounted switch selects between electronically balanced inputs via either XLR-3 or RJ45 connectors, or unbalanced inputs via RCA Phono connectors. The balanced inputs can be wired unbalanced. The electronically balanced outputs are via RJ45 connectors and can also be wired unbalanced.

The RJ45 connectors are wired to be StudioHub compatible, a format defined by Radio Systems Inc.

The RB-DA6R has master left and right gain controls which are pre-set potentiometers accessible through the front panel, providing a gain range of -8dB to +18dB. An LED power indicator on the front panel shows the unit is powered.

### System Block Diagram

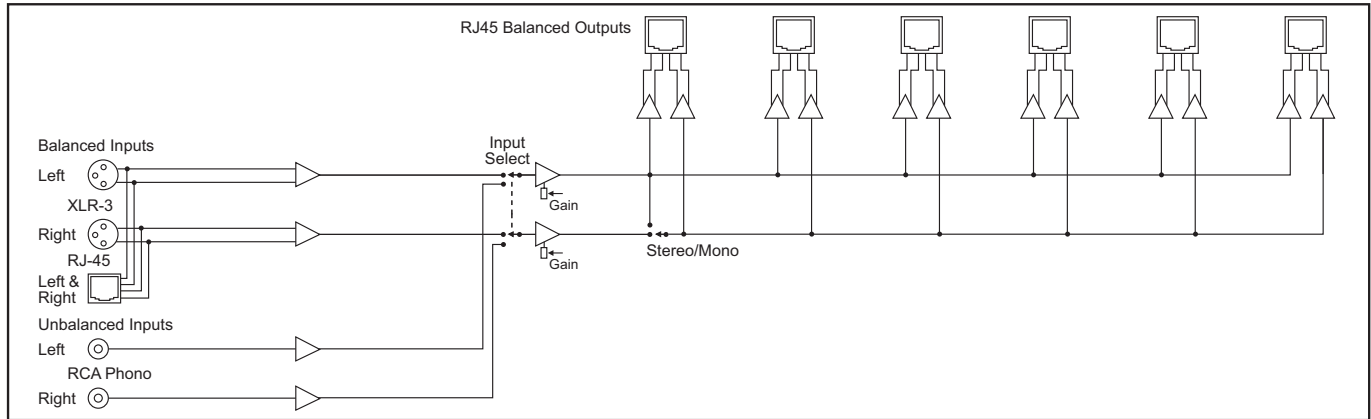

Fig 4-2: RB-DA6R System Block Diagram

### Connections and Operation

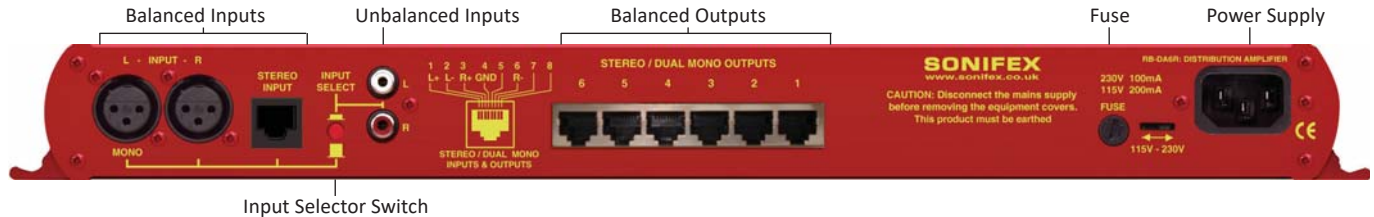

Fig 4-3: RB-DA6R Rear Panel

#### Balanced Inputs

Balanced professional inputs are provided via dual XLR-3 connectors or the single RJ45 connector. The two connector types are wired in parallel and each can take unbalanced signals by connecting the non-phase of each channel to signal ground (screen). The inputs can be configured as either stereo, with six stereo outputs, or as mono with twelve outputs.



Fig 4-4: RB-DA6R Input Selector Switch

The XLR-3 pin inputs have the following connections:  
 Pin 1: Screen  
 Pin 2: Phase  
 Pin 3: Non-Phase

The RJ45 input is wired according to the StudioHub+ standard and has the following connections:

Pin 1: Left Phase

Pin 2: Left Non-Phase

Pin 3: Right Phase

Pin 4: Screen

Pin 5: No Connection

Pin 6: Right Non-Phase

Pin 7: No Connection

Pin 8: No Connection

### Unbalanced Inputs

The RCA Phono input connectors provide an unbalanced input with an additional gain of +10dB to compensate for consumer level signals.

### Input Selector Switch

This switch controls which input is routed to the outputs; either balanced (XLR-3 or RJ45) or unbalanced (RCA Phono).

### Stereo Outputs 1-6 (Mono Outputs 1-12)

The electronically balanced outputs, which can be wired unbalanced, are via six RJ45 connectors. Each output is individually buffered so that a short on one output will not affect the others. They are wired according to the StudioHub+ standard and have the following connections:

Pin 1: Left Phase

Pin 2: Left Non-Phase

Pin 3: Right Phase

Pin 4: Screen

Pin 5: No Connection

Pin 6: Right Non-Phase

Pin 7: No Connection

Pin 8: No Connection

### Input Gain Control

The input gain on the RB-DA6R can be varied -8dB to +18dB by adjusting the pre-set potentiometers. These are accessible through the holes in the front panel. The RB-DA6R has separate left and right master gain controls.



Fig 4-5: RB-DA6R Front Panel Input Gain Controls and Stereo/Mono Switch

### Stereo/Mono Operation

The mode of operation may be switched between a stereo distributed channel to 6 stereo channels, and a mono channel to 12 mono channels, by the push button on the front panel, which is recessed to prevent accidental switching. In mono mode the left input channel is distributed to all outputs.

## Technical Specification RB-DA6R

### Audio Specifications

Input Impedance (XLR): >20k $\Omega$  balanced bridging

Input Impedance (RCA): >20k $\Omega$  unbalanced

Output Impedance: <50 $\Omega$

Maximum Input Level: +28dBu

Maximum Output Level: +28dBu

Frequency Response: 20Hz to 20kHz  $\pm$  0.1dB (600R load, ref 1kHz)

Gain Range: Adjustable 8dB loss to 18dB gain

Common Mode Rejection:>66dB typically

Distortion: 0.01% THD @ 1kHz, ref +8dBu output

Noise: -98dB unity gain ref +8dB (RB-DA6R)  
-86dB unity gain ref +8dB (RB-DA6RG)

### Connections

Inputs: 2 x XLR-3 pin female (Balanced, can be unbalanced)  
1 x RJ45 socket (Balanced, can be unbalanced)  
2 x RCA Phono sockets (Unbalanced)

Outputs: 6 x RJ45 socket (Balanced, can be unbalanced)

Mains Input: Filtered IEC, 110V-120V, or 220V-240V, fused, 6W max

Fuse Rating: Anti-surge fuse 100mA 20 x 5mm (230VAC)  
Anti-surge fuse 200mA 20 x 5mm (115VAC)

### Equipment Type

RB-DA6R:  6 way stereo distribution amplifier with RJ45 outputs

### Physical Specifications

Dimensions (Raw): 48cm (W) x 10.8cm (D) x 4.2cm (H) (1U)  
19" (W) x 4.3" (D) x 1.7" (H) (1U)

Dimensions (Boxed): 53cm (W) x 20.5cm (D) x 6cm (H)  
21" (W) x 8" (D) x 2.4" (H)

Weight: Nett: 1.3kg Gross: 1.9kg  
Nett: 2.9lbs Gross: 4.2lbs

## 5 RB-DA6RG 6 Way Stereo Distribution Amplifier With RJ45 Outputs

### Introduction

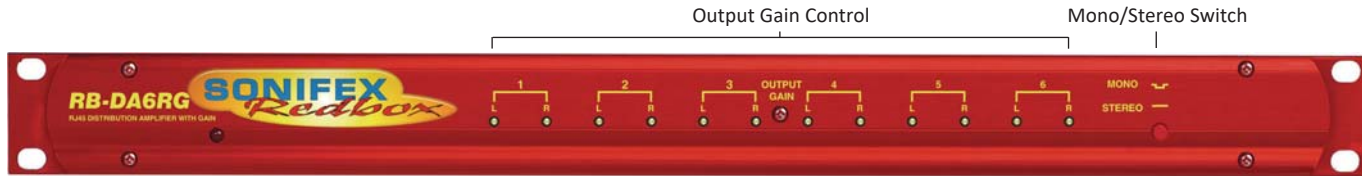

Fig 5-1: RB-DA6RG Front Panel

The RB-DA6RG is a high performance 6 way stereo analogue distribution amplifiers for splitting a source to a number of different outputs. The RB-DA6R has 1 stereo input and 6 stereo outputs with individual gain control on every output. It can also be configured so that 1 mono input is distributed to 12 outputs.

A rear panel mounted switch selects between electronically balanced inputs via either XLR-3 or RJ45 connectors, or unbalanced inputs via RCA Phono connectors. The balanced inputs can be wired unbalanced. The electronically balanced outputs are via RJ45 connectors and can also be wired unbalanced.

The RJ45 connectors are wired to be StudioHub compatible, a format defined by Radio Systems Inc.

On the RB-DA6RG each channel has an individual output gain control (normalising) which are all pre-set potentiometers, also accessible through the front panel. These can similarly be adjusted between -8db and +18dB. An extra 10dB of gain is applied to the unbalanced inputs to compensate for lower level consumer signals. The 1-12 mono, 1-6 stereo switch is recessed on the front panel to prevent accidental knocking. An LED power indicator on the front panel shows the unit is powered.

### System Block Diagram

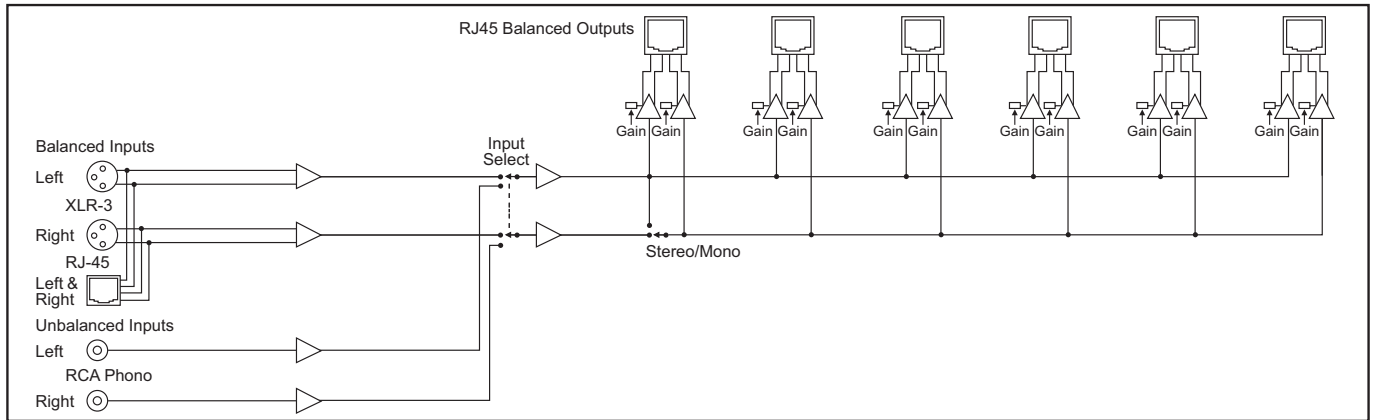

Fig 5-2: RB-DA6RG System Block Diagram

### Connections and Operation

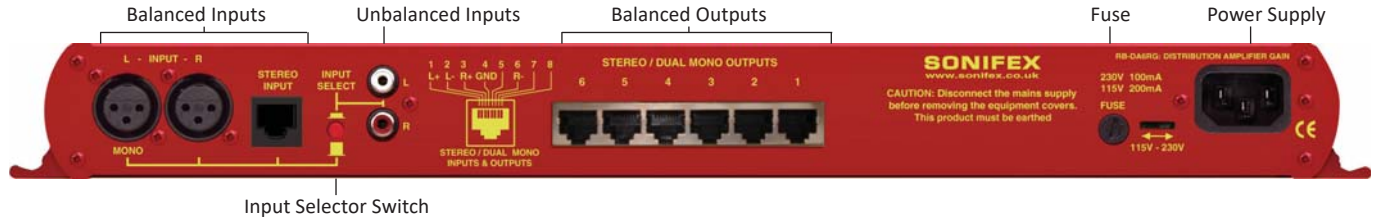

Fig 5-3: RB-DA6RG Rear Panel

### Balanced Inputs

Balanced professional inputs are provided via dual XLR-3 connectors or the single RJ45 connector. The two connector types are wired in parallel and each can take unbalanced signals by connecting the non-phase of each channel to signal ground (screen). The inputs can be configured as either stereo, with six stereo outputs, or as mono with twelve outputs.



Fig 5-4: RB-DA6RG  
Input Selector Switch

The XLR-3 pin inputs have the following connections:

- Pin 1: Screen
- Pin 2: Phase
- Pin 3: Non-Phase

The RJ45 input is wired according to the StudioHub+ standard and has the following connections:

- Pin 1: Left Phase
- Pin 2: Left Non-Phase
- Pin 3: Right Phase
- Pin 4: Screen
- Pin 5: No Connection
- Pin 6: Right Non-Phase
- Pin 7: No Connection
- Pin 8: No Connection

### Unbalanced Inputs

The RCA Phono input connectors provide an unbalanced input with an additional gain of +10dB to compensate for consumer level signals.

### Input Selector Switch

This switch controls which input is routed to the outputs; either balanced (XLR-3 or RJ45) or unbalanced (RCA Phono).

### Stereo Outputs 1-6 (Mono Outputs 1-12)

The electronically balanced outputs, which can be wired unbalanced, are via six RJ45 connectors. Each output is individually buffered so that a short on one output will not affect the others. They are wired according to the StudioHub+ standard and have the following connections:

- Pin 1: Left Phase
- Pin 2: Left Non-Phase
- Pin 3: Right Phase
- Pin 4: Screen
- Pin 5: No Connection
- Pin 6: Right Non-Phase
- Pin 7: No Connection
- Pin 8: No Connection

### Output Gain Control

The output gain on the RB-DA6RG can be varied -8dB to +18dB by adjusting the pre-set potentiometers. These are accessible through the holes in the front panel. The RB-DA6RG has output gain controls on every output.



Fig 5-5: RB-DA6RG Front Panel Output Gain Controls and Stereo/Mono Switch

### Stereo/Mono Operation

The mode of operation may be switched between a stereo distributed channel to 6 stereo channels, and a mono channel to 12 mono channels, by the push button on the front panel, which is recessed to prevent accidental switching. In mono mode the left input channel is distributed to all outputs.

## Technical Specification RB-DA6RG

### Audio Specifications

Input Impedance (XLR): >20k $\Omega$  balanced bridging

Input Impedance (RCA): >20k $\Omega$  unbalanced

Output Impedance: <50 $\Omega$

Maximum Input Level: +28dBu

Maximum Output Level: +28dBu

Frequency Response: 20Hz to 20kHz  $\pm$  0.1dB (600R load, ref 1kHz)

Gain Range: Adjustable 8dB loss to 18dB gain

Common Mode Rejection:>66dB typically

Distortion: 0.01% THD @ 1kHz, ref +8dBu output

Noise: -98dB unity gain ref +8dB (RB-DA6R)  
-86dB unity gain ref +8dB (RB-DA6RG)

### Connections

Inputs:	2 x XLR-3 pin female (Balanced, can be unbalanced) 1 x RJ45 socket (Balanced, can be unbalanced) 2 x RCA Phono sockets (Unbalanced)
Outputs:	6 x RJ45 socket (Balanced, can be unbalanced)
Mains Input:	Filtered IEC, 110V-120V, or 220V-240V, fused, 6W max
Fuse Rating:	Anti-surge fuse 100mA 20 x 5mm (230VAC) Anti-surge fuse 200mA 20 x 5mm (115VAC)

### Equipment Type

RB-DA6RG:  6 way stereo distribution amplifier with RJ45 outputs and output gain

### Physical Specifications

Dimensions (Raw):	48cm (W) x 10.8cm (D) x 4.2cm (H) (1U) 19" (W) x 4.3" (D) x 1.7" (H) (1U)
Dimensions (Boxed):	53cm (W) x 20.5cm (D) x 6cm (H) 21" (W) x 8" (D) x 2.4" (H)
Weight:	Nett: 1.3kg Gross: 1.9kg Nett: 2.9lbs Gross: 4.2lbs

## 6 RB-DA4x5 4 Input, 4 x 5 Output Distribution Amplifier/Mixer

### Introduction

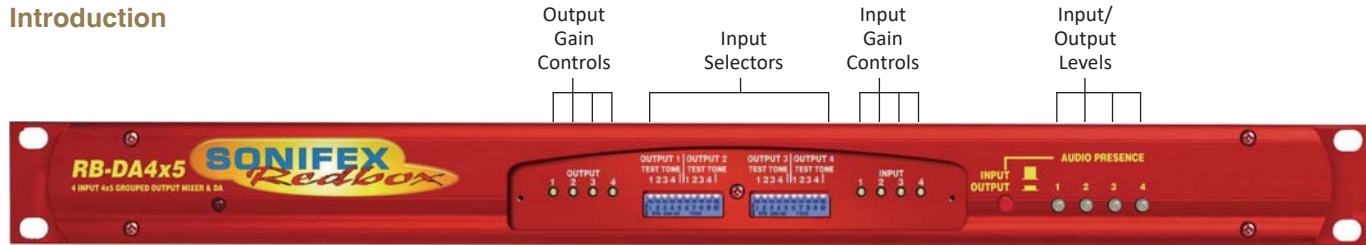

Fig 6-1: RB-DA4x5 Front Panel

The RB-DA4x5 is a 1U rack-mount combined distribution amplifier and mixer. It has 4 mono analogue audio inputs on female XLR and 4 groups of 5 outputs on 15 way D-type connectors. Each output group has a five way front-panel DIP switch assigned to it which is used to select the input(s) to send to the output group. This enables each of the four inputs, and a 1kHz 0dBu tone, to be mixed to the output group.

The inputs and outputs are electronically balanced and can be wired unbalanced. Each input has adjustable gain using a preset potentiometer, providing a gain range of -8dB to +18dB. Each output is individually buffered so that a short circuit on one output will not affect the others. The output gain of each group can similarly be adjusted between -8dB and +18dB using preset potentiometers.

The DIP switch settings and gain controls are recessed beneath a front-mounting screw-on cover so that settings can not be accidentally altered, for secure applications. Four bright front-panel signal present LEDs show the levels of either the inputs or the output groups by pressing the AUDIO PRESENCE button. The LEDs will show green illumination from -12dBu through to 0dBu, amber from 0dBu through to +6dBu and red for inputs and outputs at +6dBu and over.

### System Block Diagram

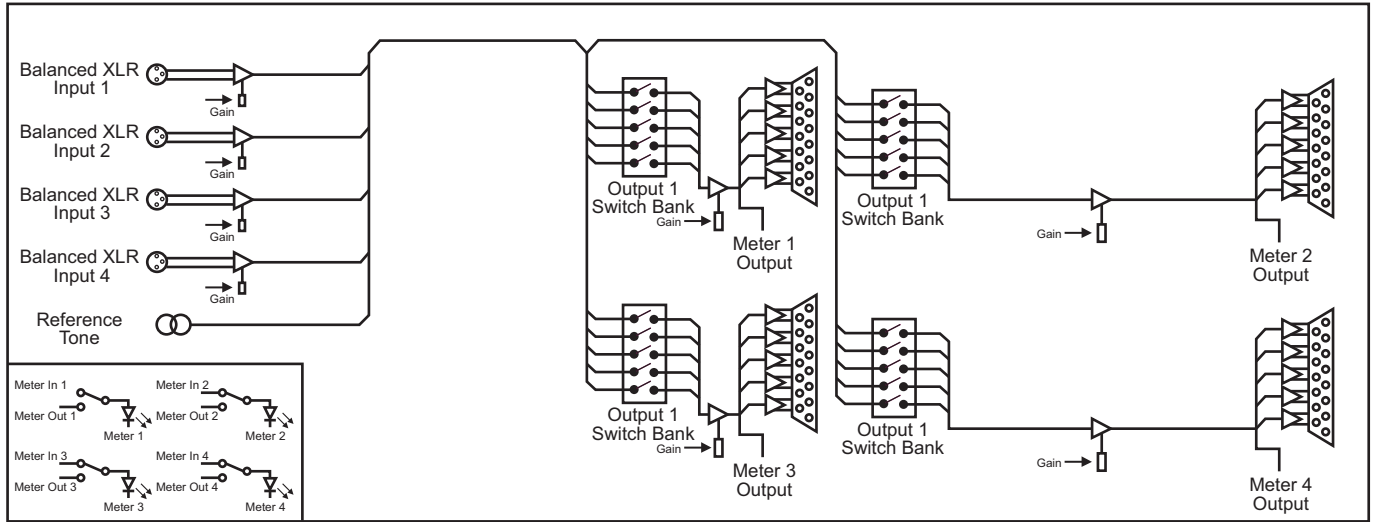

Fig 6-2: RB-DA4x5 System Block Diagram

### Rear Panel Connections and Operation

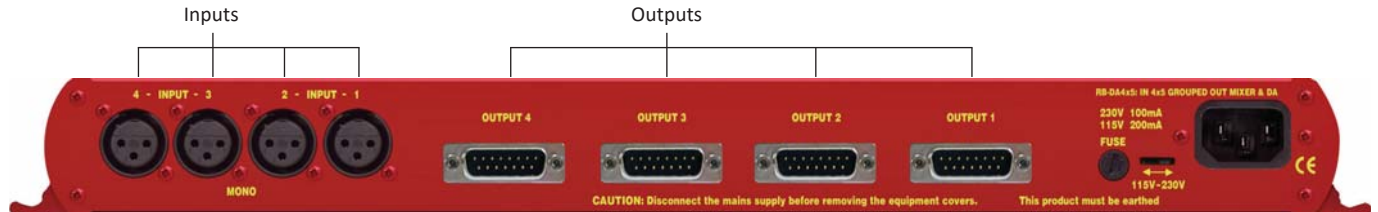

Fig 6-3: RB-DA4x5 Rear Panel

### Audio Inputs 1-4

The XLR 3 pin sockets used for the audio inputs are electronically balanced and have an impedance of 20kΩ bridging. They are routed to the switch matrix. Each XLR has the following connections:

Pin 1: Screen

Pin 2: Phase

Pin 3: Non-phase

### D-Type Audio Output Groups 1-4

Each output group connector has 5xDA driven balanced audio outputs on a D-type connector outputs each with an output impedance of <50Ω.

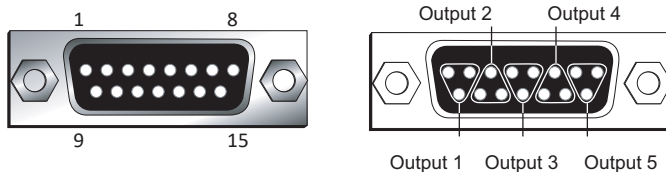

Fig 6-4: RB-DA4x5 Audio Output Group 15-Way D-Type Plug

Function	Output 1	Output 2	Output 3	Output 4	Output 5
Out - Pin No.	1	3	4	6	7
Out + Pin No.	9	10	12	13	15
Signal Ground Pin No.	2	11	5	14	8

Fig 6-5: RB-DA4x5 Pinout for Audio Output Group Connector

### Monitor LEDs

There are 4 LEDs on the front panel that indicate the relative levels of the audio signals at the inputs or outputs. A pushbutton switch on the front panel toggles the function of these LEDs between input and output. These LEDs indicate the levels of the signals by illuminating green for signals between -12 and 0dBu, illuminating yellow for signals between 0 and +6dBu, and illuminating red for signals over +6dBu.

### Input Level Adjustment

The gain for each input can be adjusted through pre-set potentiometers that are accessible from behind the removable plate on the front panel. The gain of each balanced input is variable within a range of -8dB to +18dB into the router input.

### Output Level Adjustment

The gain for each output group can be adjusted through pre-set potentiometers that are accessible from behind the removable plate on the front panel. The gain of each output group is variable within a range of -8dB to +18dB from the router output.

### Routing Selection

Each output group is capable of selecting its signal from any combination of inputs and the test tone. Set the appropriate dip-switch for that group & that input to the on position to include the signal in the group's output.

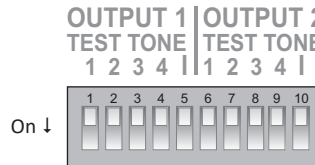

Fig 6-6: RB-DA4x5 Routing Selection Switch

Function	Group 1 Routing	Group 2 Routing	Group 3 Routing	Group 4 Routing
Input 1	SW1-1 On	SW1-6 On	SW2-1 On	SW2-6 On
Input 2	SW1-2 On	SW1-7 On	SW2-2 On	SW2-7 On
Input 3	SW1-3 On	SW1-8 On	SW2-3 On	SW2-8 On
Input 4	SW1-4 On	SW1-9 On	SW2-4 On	SW2-9 On
Test Tone	SW1-5 On	SW1-10 On	SW2-5 On	SW2-10 On

Fig 6-7: RB-DA4x5 Routing Selection Switch Functions

### Alignment Test Tone

Each of the output groups has the capability of selecting a 1kHz, 0dBu test tone. This signal can be used as a reference to set the output gain levels. Once these values are known then the input gains can be set by providing a known tone to the input and adjusting the input gain to the required level. It is possible to use this test tone as a reference level for the input gain by adjusting the output gains to unity and then looping back any output to the input connector. The on-board oscillator is temperature sensitive and in cold conditions may take a short time to start oscillating. In any case you should always allow the unit to fully come to its normal operating temperature before adjusting the gains.

## Technical Specifications RB-DA4x5

### Audio Specifications

Maximum Input Level:	+28dBu
Input Impedance (XLR):	>20kΩ balanced bridging
Output Impedance:	<50Ω
Maximum Output Level:	+28dBu
Distortion:	0.01% THD @ 1kHz, ref +8dBu output
Noise:	-100dB, unity gain, ref +8dBu output
Common Mode Rejection:	>66dB typically
Frequency Response:	20Hz to 20kHz ±0.1dB (600Ω load, ref 1kHz)
Input Gain Range:	Adjustable 8dB loss to 18dB gain (channel 1-4 adjust)
Output Gain Range:	Adjustable 8dB loss to 18dB gain (group 1-4 adjust)

### Connections

Inputs (4 x Mono):	4 x XLR 3 pin female (Balanced)
Outputs (20 x Mono):	4 x 15 way D-type (Balanced)
Mains Input:	Filtered IEC, 110V-120V, or 220-240V switchable, fused, 9W maximum
Fuse Rating:	Anti-surge fuse 100mA 20 x 5mm (230VAC) Anti-surge fuse 250mA 20 x 5mm (115VAC)

### Equipment Type

RB-DA4x5:	 4 input to 20 output distribution amplifier & mixer
-----------	--

### Physical Specifications

Dimensions (Raw):	48cm (W) x 15.8cm (D*) x 4.2cm (H) (1U) 19" (W) x 6.2" (D*) x 1.7 (H) (1U)
Dimensions (Boxed):	59cm (W) x 27.4cm (D*) x 10.8cm (H) 23.2" (W) x 10.8" (D*) x 4.3" (H)
Weight:	Nett: 1.6kg Gross: 2.2kg Nett: 3.5lbs Gross: 4.8lbs

\* Note that this product is deeper than standard redboxes.

## 7 RB-DA24MD 24 Way Mono Audio Distribution Amplifier

### Introduction



Fig 7-1: RB-DA24MD Front Panel

The RB-DA24MD is a 1U rack mount high performance 24 way audio distribution amplifier. It has 2 inputs which can be each individually routed to 12 outputs, or mixed and routed to all 24 outputs.

The XLR inputs and D-type outputs are electronically balanced and can be wired unbalanced. Each output is individually buffered so that a short circuit on one won't affect the others. Each output is also protected against connection to both POE (power over Ethernet) and phantom power circuits.

The RB-DA24MD has master gain controls for both input 1 and input 2 which are pre-set potentiometers accessible through the rear panel. These controls allow the gain to be adjusted from -15dB to +15dB, useful for normalising consumer to professional signals and vice versa. An LED power indicator on the front panel shows the unit is powered.

A 125Hz 6dB per octave roll off filter is activated by a push switch on the rear panel. When selected the filter is applied to both inputs.

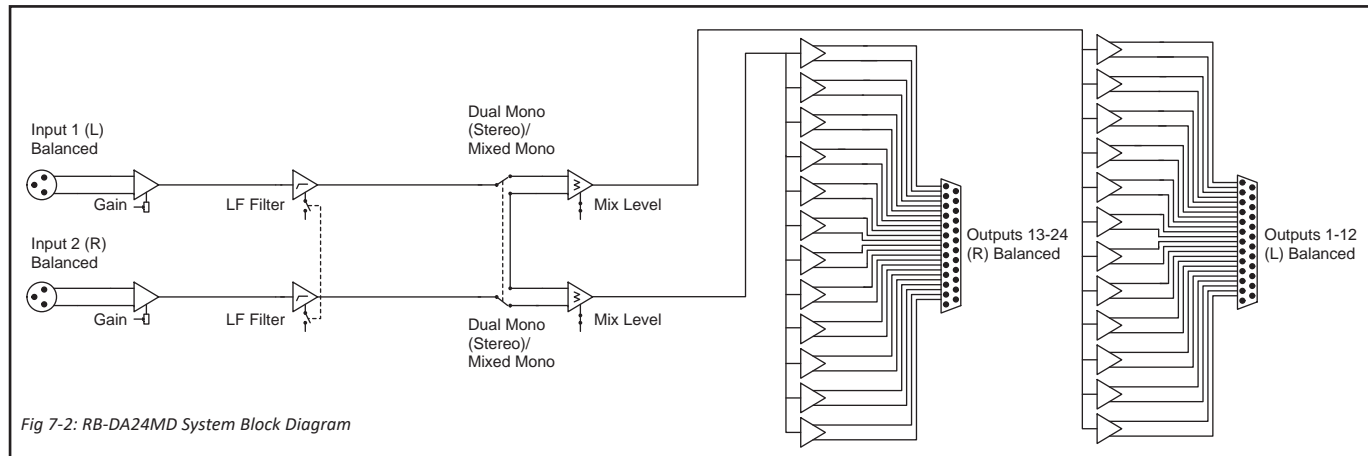

Fig 7-2: RB-DA24MD System Block Diagram

## Connections And Operation

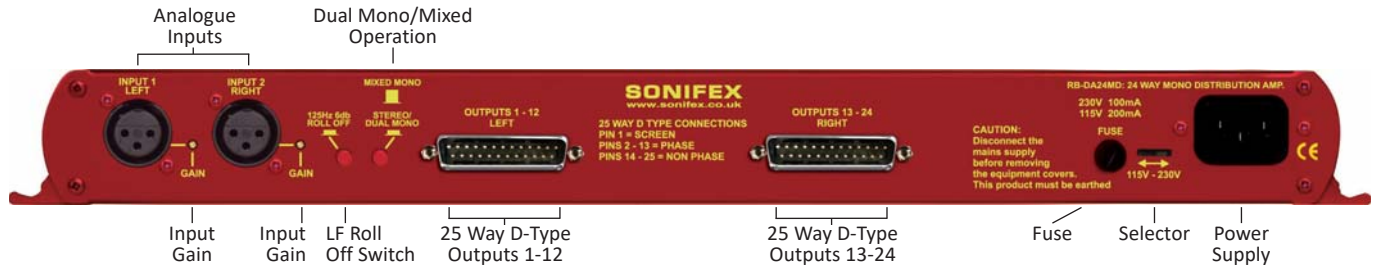

Fig 7-3: RB-DA24MD Rear Panel

### Inputs (1&2)

The XLR-3 input connectors can take balanced professional levels, or unbalanced consumer levels by connecting the non-phase to the signal ground and adjusting the rear panel input gain controls. The inputs can be configured as either dual mono, input 1 routed to outputs 1-12 and input 2 routed to outputs 13-24, or mixed mono, inputs 1 and 2 mixed at a pre-set level and routed to all 24 outputs. The XLR 3 pin input has the following connections:

Pin 1: Screen

Pin 2: Phase

Pin 3: Non-Phase

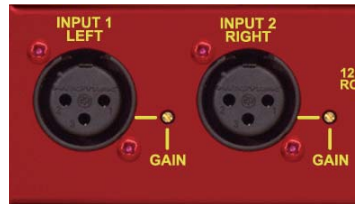

Fig 7-4: Analogue Input

### Outputs (1 – 24)

The 25 way D-type outputs are electronically balanced, and can be wired unbalanced (not recommended). Each output is individually buffered so that a short circuit on one output will not affect the others. The outputs are also protected from connection to POE (power over Ethernet) and phantom power circuits. They have the following connections:



Fig 7-5: 25 Way D-Type Outputs

	Outputs 1-12 D-Type	Outputs 13-24 D-Type
Pin No.	Signal	Signal
Pin 1	Screen	Screen
Pin 2	Output 1 - Phase	Output 13 - Phase
Pin 14	Output 1 - Non-Phase	Output 13 - Non-Phase
Pin 3	Output 2 - Phase	Output 14 - Phase
Pin 15	Output 2 - Non-Phase	Output 14 - Non-Phase
Pin 4	Output 3 - Phase	Output 15 - Phase
Pin 16	Output 3 - Non-Phase	Output 15 - Non-Phase
Pin 5	Output 4 - Phase	Output 16 - Phase
Pin 17	Output 4 - Non-Phase	Output 16 - Non-Phase
Pin 6	Output 5 - Phase	Output 17 - Phase
Pin 18	Output 5 - Non-Phase	Output 17 - Non-Phase
Pin 7	Output 6 - Phase	Output 18 - Phase
Pin 19	Output 6 - Non-Phase	Output 18 - Non-Phase
Pin 8	Output 7 - Phase	Output 19 - Phase
Pin 20	Output 7 - Non-Phase	Output 19 - Non-Phase
Pin 9	Output 8 - Phase	Output 20 - Phase
Pin 21	Output 8 - Non-Phase	Output 20 - Non-Phase
Pin 10	Output 9 - Phase	Output 21 - Phase
Pin 22	Output 9 - Non-Phase	Output 21 - Non-Phase
Pin 11	Output 10 - Phase	Output 22 - Phase
Pin 23	Output 10 - Non-Phase	Output 22 - Non-Phase
Pin 12	Output 11 - Phase	Output 23 - Phase
Pin 24	Output 11 - Non-Phase	Output 23 - Non-Phase
Pin 13	Output 12 - Phase	Output 24 - Phase
Pin 25	Output 12 - Non-Phase	Output 24 - Non-Phase

**Input Gain Control**

The input gain on the RB-DA24MD can be varied between -15dB and +15dB by adjusting the pre-set potentiometers. These are accessible through the holes in the rear panel. The RB-DA24MD has separate input 1 and input 2 gain controls.

**LF Roll Off Filter**

A low frequency roll off filter is activated by a push switch on the rear panel. This implements a 125Hz 6dB per octave roll off filter which is applied to both inputs.

**Dual Mono/Mixed Mono Operation**

The method of operation may be switched between stereo/dual mono and mixed mono. When the RB-DA24MD is set to dual mono each input is distributed separately to outputs 1-12 and 13-24. Input 1 is routed to outputs 1-12 and input 2 to 13-24. When it is set to mixed mono mode both inputs are mixed and routed to all 24 outputs.

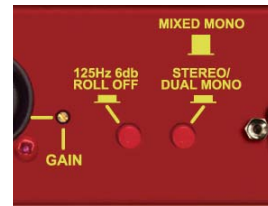

Fig 7-6: 25 Roll Off and Dual Mono/Mixed Operation Switches

**Mixed Mono Settings**

When set to mixed mono operation there are 3 different mix level modes, selected by the 4 jumpers on the PCB.

Jumper Link	Mix Mode
Off	(Input 1 + Input 2) -6dB
Pin 1 & 2	(Input 1 + Input 2) -3dB
Pin 2 & 3	Input 1 + Input 2

**All jumpers (J1 to J4) must be set the same for correct operation.**

## Technical Specifications RB-DA24MD

### Audio Specifications:

Input Impedance:	>20k $\Omega$ bridging (balanced)
Output Impedance:	<50 $\Omega$
Maximum Input Level:	+28dBu
Maximum Output Level:	+28dBu
Frequency Response:	20Hz to 20kHz $\pm$ 0.1dB (600 $\Omega$ load, ref 1kHz)
Gain Range:	Adjustable -15dB loss to +15dB gain
Common Mode Rejection:	>66dB typically
LF Roll Off Filter	125Hz at 6dB/octave
Distortion:	0.01%THD @ 1kHz, red + 8dBu output
Noise:	-100dB unity gain, ref +8dBu output

### Connections:

Inputs:	2 x XLR 3 pin female (balanced)
Outputs:	2 x 25 way D-type plug (balanced, can be unbalanced)
Mains Input:	Filtered IEC, switchable 110-120V, or 220-240V, fused, 12W maximum
Fuse Rating:	Anti-surge fuse 100mA x 5mm (230VAC) Anti-surge fuse 200mA x 5mm (115VAC)

### Equipment Type:

Equipment Type: RB-DA24MD 24 Way Mono Distribution Amplifier



### Physical Specification:

Dimensions (Raw):	48cm (W) x 15.8cm (D) x 4.2 (H) (1U) 19" (W) x 6.2" (D) x 1.7" (H) (1U)
Dimensions (Boxed)	58.5cm (W) x 27.4cm (D) x 10.8cm (H) 23" (W) x 10.9" (D) x 4.3" (H)
Weight	Nett: 1.6kg Gross: 2.2kg Nett: 3.5lbs Gross: 4.8lbs

## 8 RB-DDA6A 6 Way Stereo AES/EBU Digital Distribution Amplifier

### Introduction



Fig 8-1: RB-DDA6A Front Panel

**24<sup>BIT</sup>**  
**192<sup>ks/s</sup>** The RB-DDA6A digital distribution amplifier is used for distributing digital audio data in AES/EBU format, repeating both the audio data and the status information of the input whilst re-normalising to standard digital audio levels.

It has a single XLR-3 female AES/EBU audio input which is distributed to 6 XLR-3 male AES/EBU outputs.

Applications include distributing audio from a digital mixing desk to multiple digital recorders, or feeding multiple studios with an output from a DAT machine.

It can accept input sample rates in the range of 30kHz - 100kHz, and bit rates of 16, 20 and 24 bit. So, it can be used for standard CD signal distribution at 16 bit 44.1kHz, as well as for high quality 24 bit 96kHz recording.

### AES/EBU Input

The XLR 3 pin socket has an impedance of 110Ω. It has the following connections:

- Pin 1: Screen
- Pin 2: Phase
- Pin 3: Non-phase

### AES/EBU Outputs

The XLR 3 pin sockets have an impedance of 110Ω. They have the following connections:

- Pin 1: Screen
- Pin 2: Phase
- Pin 3: Non-phase

### Rear Panel Connections and Operations



Fig 8-2: RB-DDA6A Rear panel

System Block Diagram

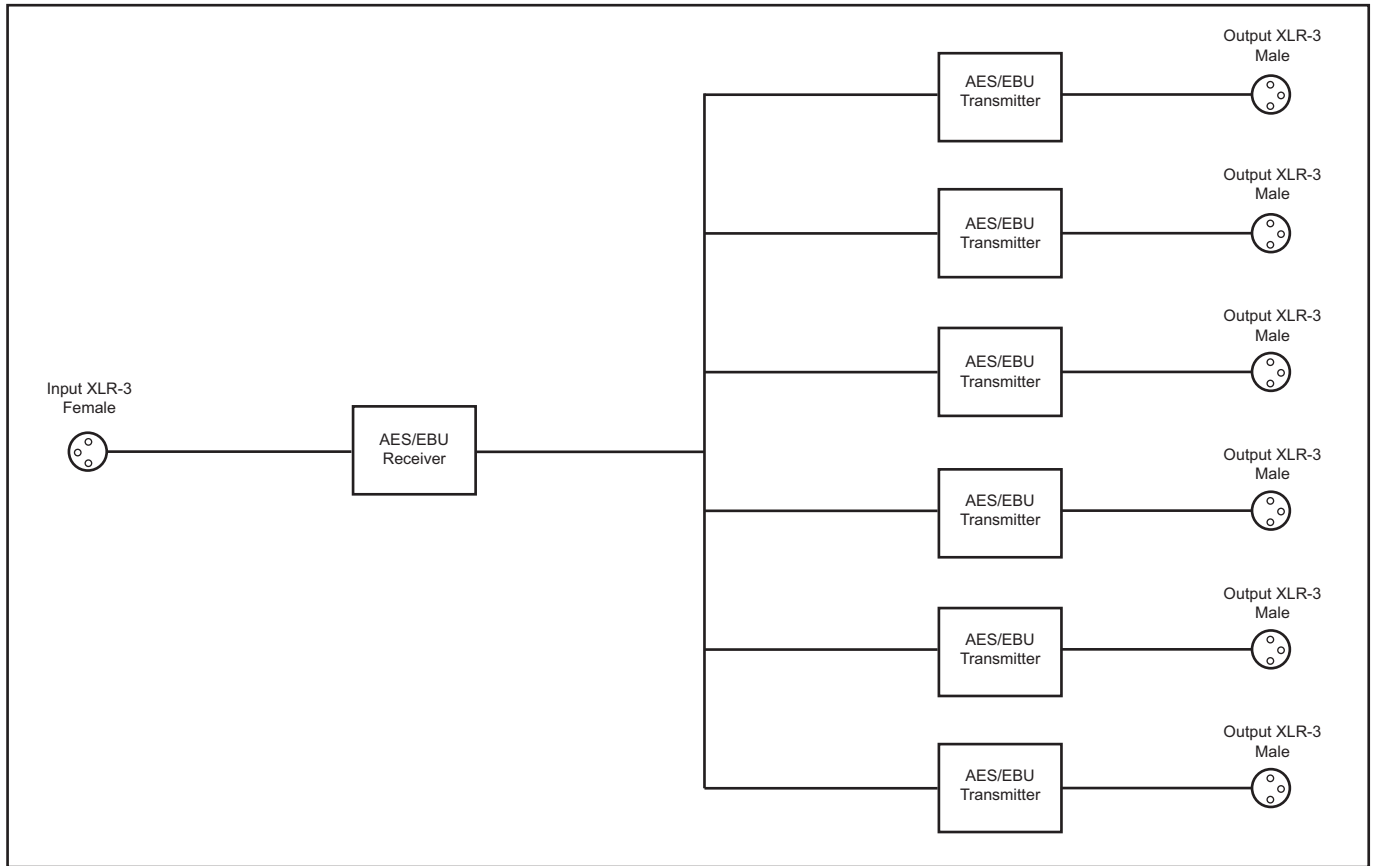

Fig 8-3: RB-DDA6A System Block Diagram

## Technical Specifications RB-DDA6A

### Audio Specifications

Input Impedance:	110Ω ± 20% balanced
Output Impedance:	110Ω ± 20% balanced
Sample Freq Range:	30-100kHz (i.e. including 32kHz, 44.1kHz, 48kHz, 64kHz, 88.2kHz and 96kHz)
Signal Level:	2V/7V peak to peak min/max

### Connections

Input:	1 x AES/EBU XLR 3 pin female (balanced)
Outputs:	6 x AES/EBU XLR 3 pin male (balanced)
Mains Input:	Filtered IEC, 110-120V, or 220-240V switchable, fused, 6W max
Fuse Rating:	Anti-surge fuse 100mA 20 x 5mm (230VAC) Anti-surge fuse 250mA 20 x 5mm (115VAC)

### Equipment Type

RB-DDA6A   6 way AES/EBU stereo digital distribution amplifier

### Physical Specifications

Dimensions (Raw):	28cm (W) x 10.8cm (D) x 4.2cm (H) (1U) 11" (W) x 4.3" (D) x 1.7" (H) (1U)
Dimensions (Boxed):	36cm (W) x 20.5cm (D) x 6cm (H) 14.2" (W) x 8" (D) x 2.4" (H)
Weight:	Nett: 0.95kg    Gross: 1.4kg Nett: 2.1lbs    Gross: 3.2lbs

## 9 RB-DDA6A-2P 6 Way Stereo AES/EBU Digital Distribution Amplifier With Dual Power Supplies

### Introduction



Fig 9-1: RB-DDA6A-2P Front Panel

The RB-DDA6A-2P digital distribution amplifier is used for distributing digital audio data in AES/EBU format, repeating both the audio data and the status information of the input whilst re-normalising to standard digital audio levels.

It has a single XLR-3 female AES/EBU audio input which is distributed to 6 XLR-3 male AES/EBU outputs.

Applications include distributing audio from a digital mixing desk to multiple digital recorders, or feeding multiple studios with an output from a DAT machine.

It can accept input sample rates in the range of 30kHz - 100kHz, and bit rates of 16, 20 and 24 bit. So, it can be used for standard CD signal distribution at 16 bit 44.1kHz, as well as for high quality 24 bit 96kHz recording.

The unit provides redundancy protection by using two power supply units that can be supplied from separate mains feeds. The unit automatically load shares between the two supplies so that if either supply should fail the unit will continue to work correctly. If both supplies fail the input is connected directly to output 1.

The condition of the two supplies is indicated on the front panel by two red LEDs which illuminate to indicate the correct function of the supply. On the alarm output connector there is a changeover relay to indicate the status of each supply. This is normally closed to indicate power fail and once the supply is working correctly the relay activates to make a normally open contact.

System Block Diagram

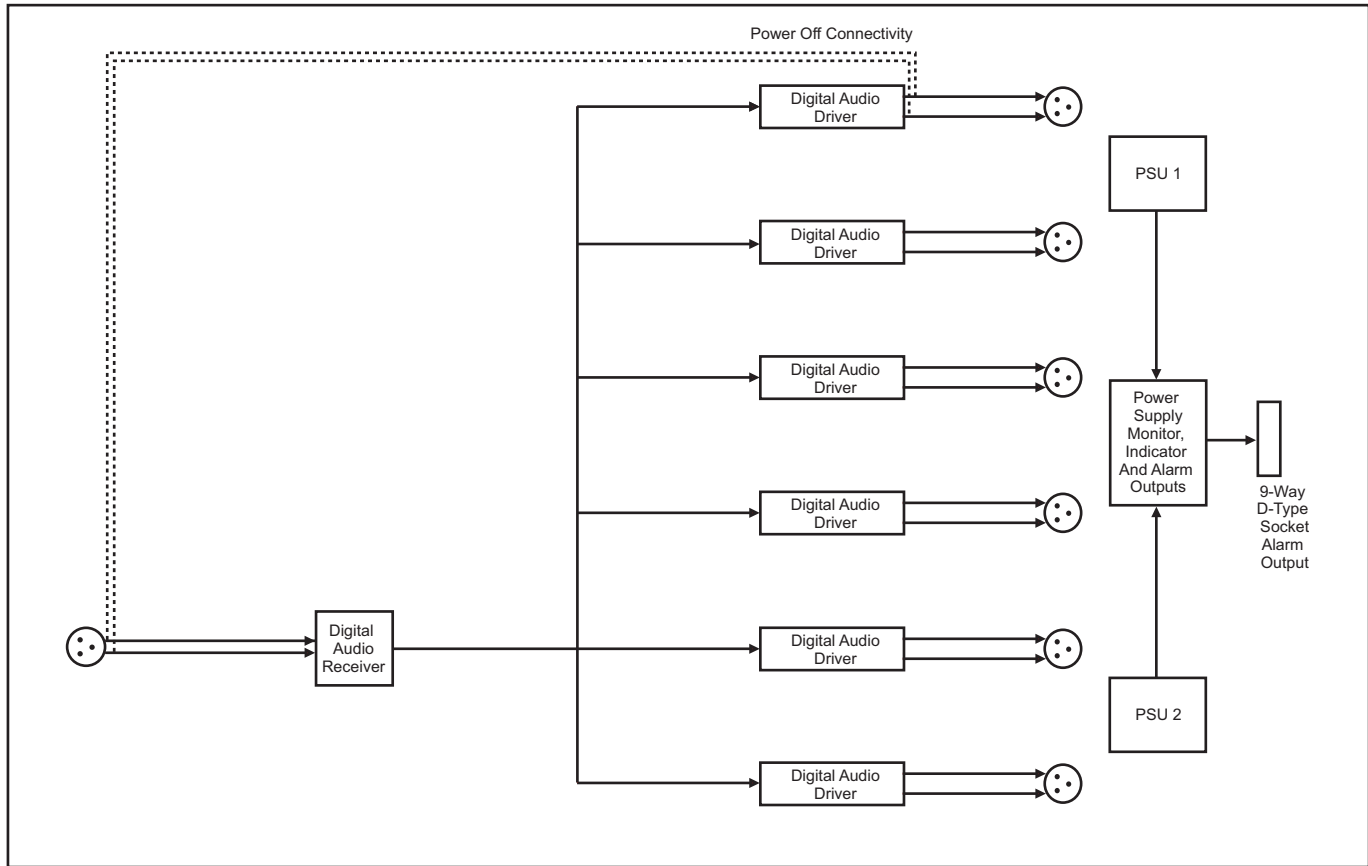

Fig 9-2: RB-DDA6A-2P System Block Diagram

## Rear Panel Connections and Operations



Fig 9-3: RB-DDA6A-2P Rear panel

### AES/EBU Input

The XLR 3 pin socket has an impedance of 110Ω. It has the following connections:

Pin 1: Screen

Pin 2: Phase

Pin 3: Non-phase

### AES/EBU Outputs

The XLR 3 pin sockets have an impedance of 110Ω. They have the following connections:

Pin 1: Screen

Pin 2: Phase

Pin 3: Non-phase

### Alarm Connector

Pin 1: Power Supply 1 Common

Pin 2: Power Supply 1 Normally Open

Pin 3: Ground

Pin 4: Power Supply 2 Common

Pin 5: Power Supply 2 Normally Open

Pin 6: Power Supply 1 Normally Closed (indicates supply inactive)

Pin 7: Ground

Pin 8: Ground

Pin 9: Power Supply 2 Normally Closed (indicates supply inactive)

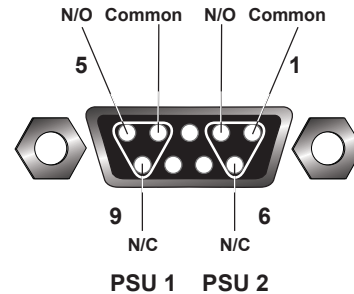

Fig 9-4: RB-DDA6A-2P Alarm Connector Diagram

## Technical Specification RB-DDA6A-2P

### Audio Specifications

Input Impedance:	110Ω ± 20% balanced
Output Impedance:	110Ω ± 20% balanced
Sample Freq Range:	30-100kHz (i.e. including 32kHz, 44.1kHz, 48kHz, 64kHz, 88.2kHz and 96kHz)
Signal Level:	2V/7V peak to peak min/max

### Connections

Audio Input:	1 x AES/EBU XLR 3 pin female (balanced)
Audio Outputs:	6 x AES/EBU XLR 3 pin male (balanced)
Alarm Outputs:	2 x Relay output indicators on 1 x 9 pin D-Type socket
Mains Inputs:	2 x Filtered IEC, 85-264V switchable, fused, 6W max
Fuse Ratings:	2 x Anti-surge fuse 1A 20 x 5mm

### Equipment Type

RB-DDA6A-2P:	 6 way AES/EBU stereo digital distribution amplifier with dual power supplies
--------------	--

### Physical Specifications

Dimensions (Raw):	48cm (W) x 10.8cm (D) x 4.2cm (H) (1U) 19" (W) x 4.3" (D) x 1.7" (H) (1U)
Dimensions (Boxed):	58.5cm (W) x 22.5cm (D) x 7cm (H) 23" (W) x 8.9" (D) x 2.8" (H)
Weight:	Nett: 1.5kg    Gross: 2.0kg Nett: 3.3lbs    Gross: 4.4lbs

# 10 RB-DDA6A3 6 Way Stereo AES-3id Digital Audio Distribution Amplifier

## Introduction



Fig 10-1: RB-DDA6A3 Front Panel

**24<sup>BIT</sup>**  
**192<sup>kHz</sup>** The RB-DDA6A3 digital distribution amplifier is used for distributing digital audio data in AES-3id format, repeating both the audio data and the status information of the input whilst re-normalising to standard AES-3id digital audio levels.

It has a single female BNC AES-3id audio input which is distributed to 6 female BNC AES-3id outputs.

It can accept input sample rates in the range of 30kHz - 100kHz, and bit rates of 16, 20 and 24 bit.

### AES-3id Input

The AES-3id input has an impedance of 75Ω.

### AES-3id Outputs

The AES-3id outputs have an impedance of 75Ω.

## Rear Panel Connections and Operations

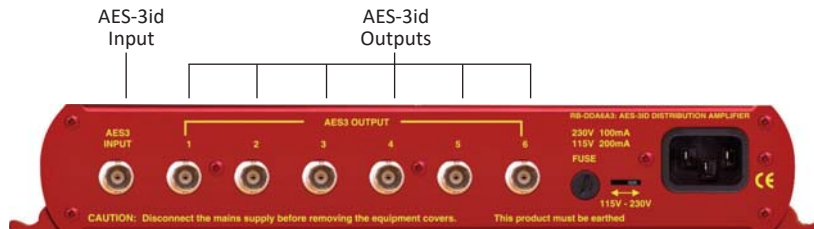

Fig 10-2: RB-DDA6A3 Rear panel

System Block Diagram

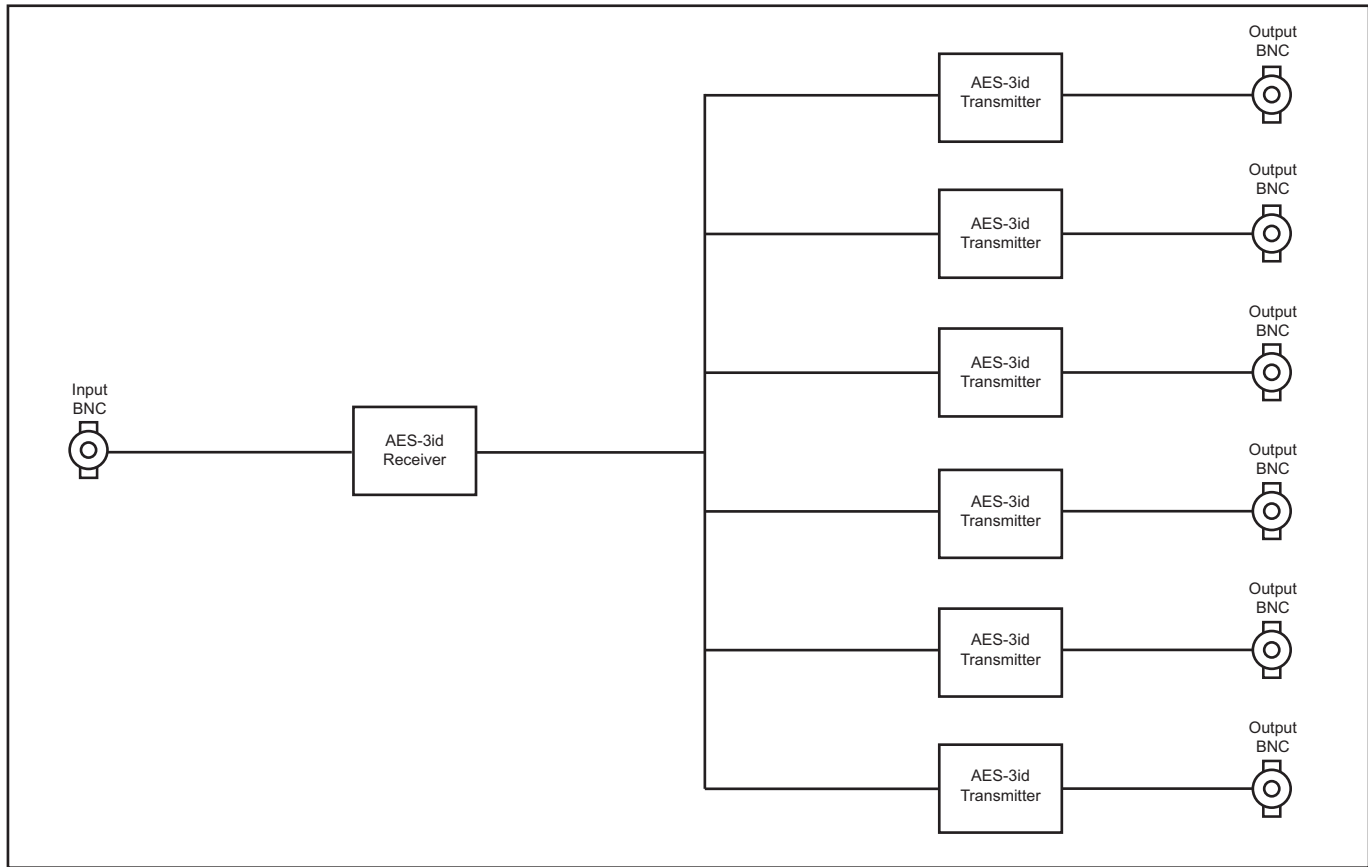

Fig 10-3: RB-DDA6A3 System Block Diagram

## Technical Specifications RB-DDA6A3

### Audio Specifications

Input Impedance:	75Ω
Output Impedance:	75Ω
Sample Freq Range:	30-100kHz (i.e. including 32kHz, 44.1kHz, 48kHz, 64kHz, 88.2kHz and 96kHz)
Signal Level:	0.8V/1.2V peak to peak min/max

### Connections

Input:	1 x BNC female
Outputs:	6 x BNC female
Mains Input:	Filtered IEC, 110-120V, or 220-240V switchable, fused, 6W max
Fuse Rating:	Anti-surge fuse 100mA 20 x 5mm (230VAC) Anti-surge fuse 250mA 20 x 5mm (115VAC)

### Equipment Type

RB-DDA6A3   6 way AES-3id stereo digital distribution amplifier

### Physical Specifications

Dimensions (Raw):	28cm (W) x 10.8cm (D) x 4.2cm (H) (1U) 11" (W) x 4.3" (D) x 1.7" (H) (1U)
Dimensions (Boxed):	36cm (W) x 20.5cm (D) x 6cm (H) 14.2" (W) x 8" (D) x 2.4" (H)
Weight:	Nett: 0.92kg    Gross: 1.46kg Nett: 2.1lbs    Gross: 3.2lbs

# 11 RB-DDA6S 6 Way Stereo S/PDIF Digital Distribution Amplifier

## Introduction



Fig 11-1: RB-DDA6S Front Panel

**24**<sup>BIT</sup>  
**192**<sup>kHz</sup>

The RB-DDA6S digital distribution amplifier is similar to the above models except that it is used for distributing digital audio data in S/PDIF format.

It has a single S/PDIF audio input which is distributed to 6 x S/PDIF audio outputs at the same level and condition as the input signal. It can accept input sample rates in the range of 30kHz - 100kHz, and bit rates of 16, 20 and 24 bit.

Uses include audio distribution at 16 bit 44.1kHz from a consumer CD player to multiple digital recorders, distribution of high quality 24 bit 96kHz signals from digital mixing desks to recorders and connection of the output of, say, a DVD player to multiple studios.

### S/PDIF Input

The S/PDIF phono input has an impedance of 75Ω.

### S/PDIF Outputs

The S/PDIF phono outputs have an impedance of 75Ω.

## Rear Panel Connections and Operations



Fig 11-2: RB-DDA6S Rear panel

System Block Diagram

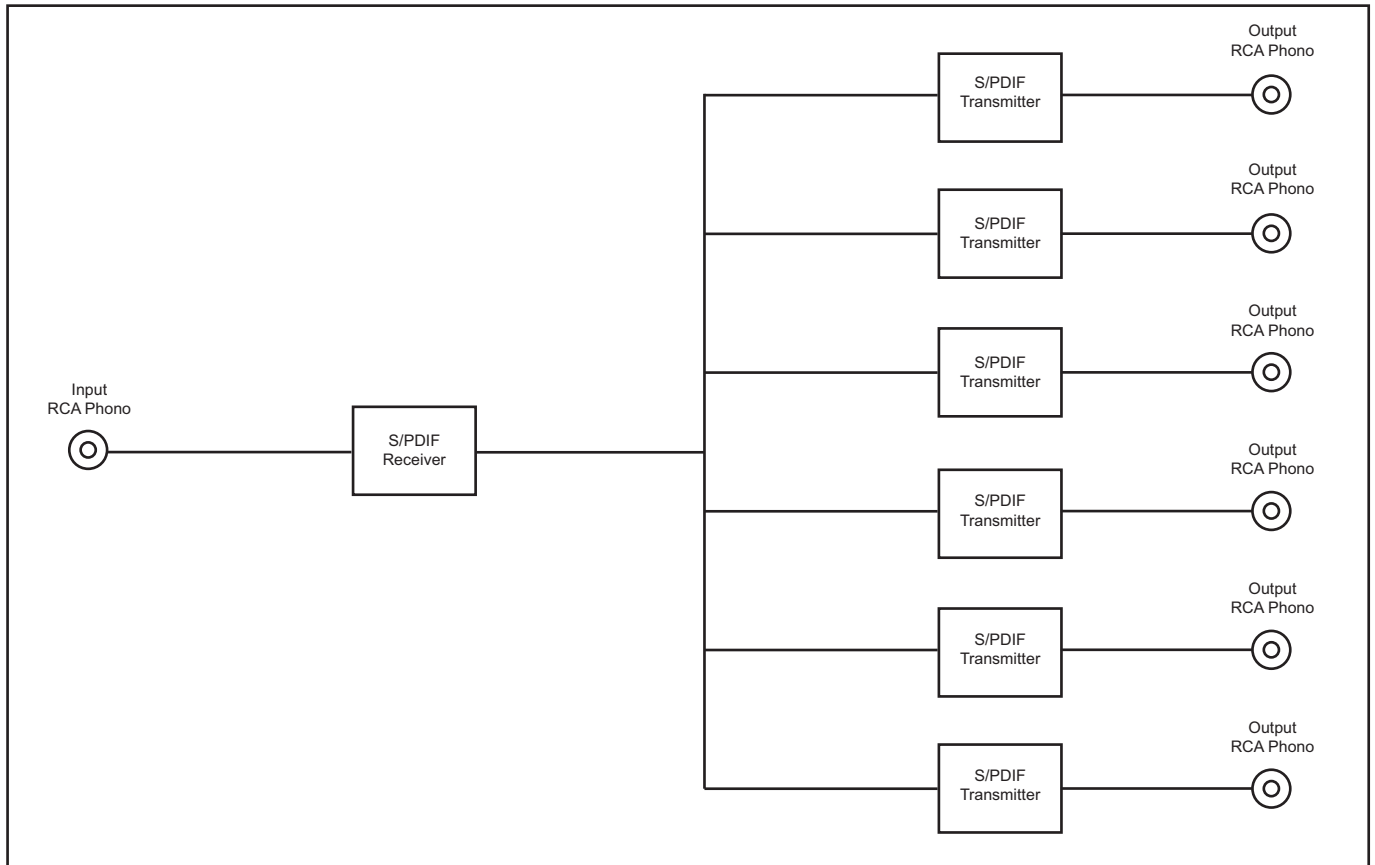

Fig 11-3: RB-DDA6S System Block Diagram

## Technical Specifications RB-DDA6S



### Audio Specifications

Input Impedance:	75Ω ±5% unbalanced
Output Impedance:	75Ω ±5% unbalanced
Sample Freq Range:	30-100kHz (i.e. including 32kHz, 44.1kHz, 48kHz, 64kHz, 88.2kHz and 96kHz)
Signal Level:	Balanced min 0.5V ±20% peak to peak

### Connections

Input (unbalanced):	1 x S/PDIF RCA phono female
Outputs:	6 x S/PDIF RCA phono female (unbalanced)
Mains Input:	Filtered IEC, 110-120V, or 220-240V switchable, fused, 6W max
Fuse Rating:	Anti-surge fuse 100mA 20 x 5mm (230VAC) Anti-surge fuse 250mA 20 x 5mm (115VAC)

### Equipment Type

RB-DDA6S   6 way stereo S/PDIF digital distribution amplifier

### Physical Specifications

Dimensions (Raw):	28cm (W) x 10.8cm (D) x 4.2cm (H) (1U) 11" (W) x 4.3" (D) x 1.7" (H) (1U)	
Dimensions (Boxed):	36cm (W) x 20.5cm (D) x 6cm (H) 14.2" (W) x 8" (D) x 2.4" (H)	
Weight RB-DDA6S:	Nett: 0.9kg	Gross: 1.35kg
	Nett: 2lbs	Gross: 3lbs

## 12 RB-DDA6W 6 Way Word Clock Distribution Amplifier

### Introduction



Fig 12-1: RB-DDA6W Front Panel

The RB-DDA6W 6 Way Word Clock Distribution Amplifier distributes a word clock BNC input signal to 6 word clock BNC outputs re-conditioned. It is used in distributing reference clocks for digital audio systems.

It has a single female BNC input which is distributed to 6 female BNC outputs.

The unit's primary application is to distribute a master TTL word clock source to multiple pieces of equipment that need to be synchronised from the master.

### Rear Panel Connections and Operations

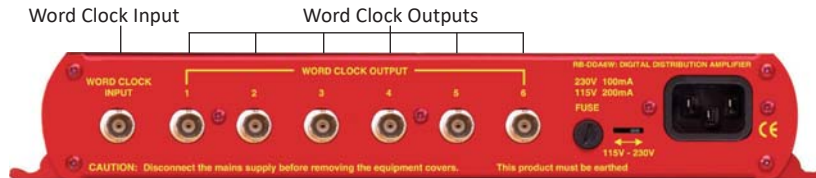

Fig 12-2: RB-DDA6W Rear Panel

#### Word Clock Input

The Word Clock BNC input has an impedance of 75  $\Omega$ .

#### Word Clock Outputs

The Word Clock BNC outputs have an impedance of <75  $\Omega$ .

System Block Diagram

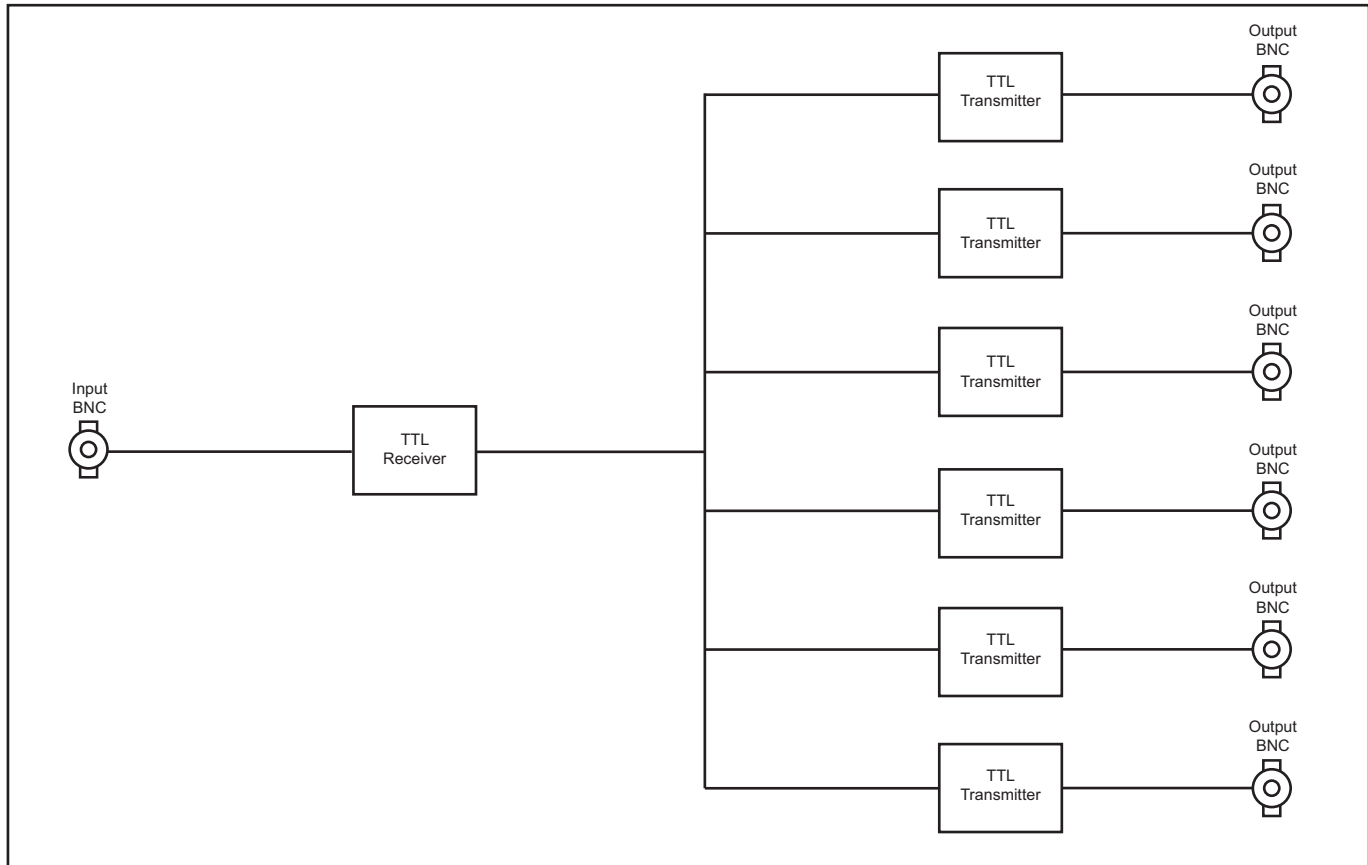

Fig 12-3: RB-DDA6W System Block Diagram

## Technical Specifications RB-DDA6W

### Signal Specifications

Input Impedance :	75Ω
Output Impedance:	<75Ω

### Connections

Input:	1 x BNC female
Outputs:	6 x BNC female
Mains Input:	Filtered IEC, 110-120V, or 220-240V switchable, fused, 6W max
Fuse Rating:	Anti-surge fuse 100mA 20 x 5mm (230VAC) Anti-surge fuse 250mA 20 x 5mm (115VAC)

### Equipment Type

RB-DDA6W:  6 way word clock distribution amplifier

### Physical Specifications

Dimensions (Raw):	28cm (W) x 10.8cm (D) x 4.2cm (H) (1U) 11" (W) x 4.3" (D) x 1.7" (H) (1U)
Dimensions (Boxed):	36cm (W) x 20.5cm (D) x 6cm (H) 14.2" (W) x 8" (D) x 2.4" (H)
Weight:	Nett: 0.9kg    Gross: 1.35kg Nett: 2lbs    Gross: 3lbs

## 13 RB-DDA6W-2P 6 Way Word Clock Distribution Amplifier With Dual Power Supplies

### Introduction



Fig 13-1: RB-DDA6W-2P Front Panel

The **RB-DDA6W-2P** word clock distribution amplifier distributes a word clock BNC input signal to 6 word clock BNC outputs re-conditioned. It is used to distribute reference clocks for digital audio systems.

It has a single female BNC audio input which is distributed to 6 female BNC outputs. The unit's primary application is to distribute a master TTL word clock source to multiple pieces of equipment that need to be synchronised from the master.

The unit provides redundancy protection by using two power supply units that can be supplied from separate mains feeds. The unit automatically load shares between the two supplies so that if either supply should fail the unit will continue to work correctly. If both supplies fail the input is connected directly to output 1.

The condition of the two supplies is indicated on the front panel by two red LEDs which illuminate to indicate the correct function of the supply. On the alarm output connector there is a changeover relay to indicate the status of each supply. This is normally closed to indicate power fail and once the supply is working correctly the relay activates to make a normally open contact.

System Block Diagram

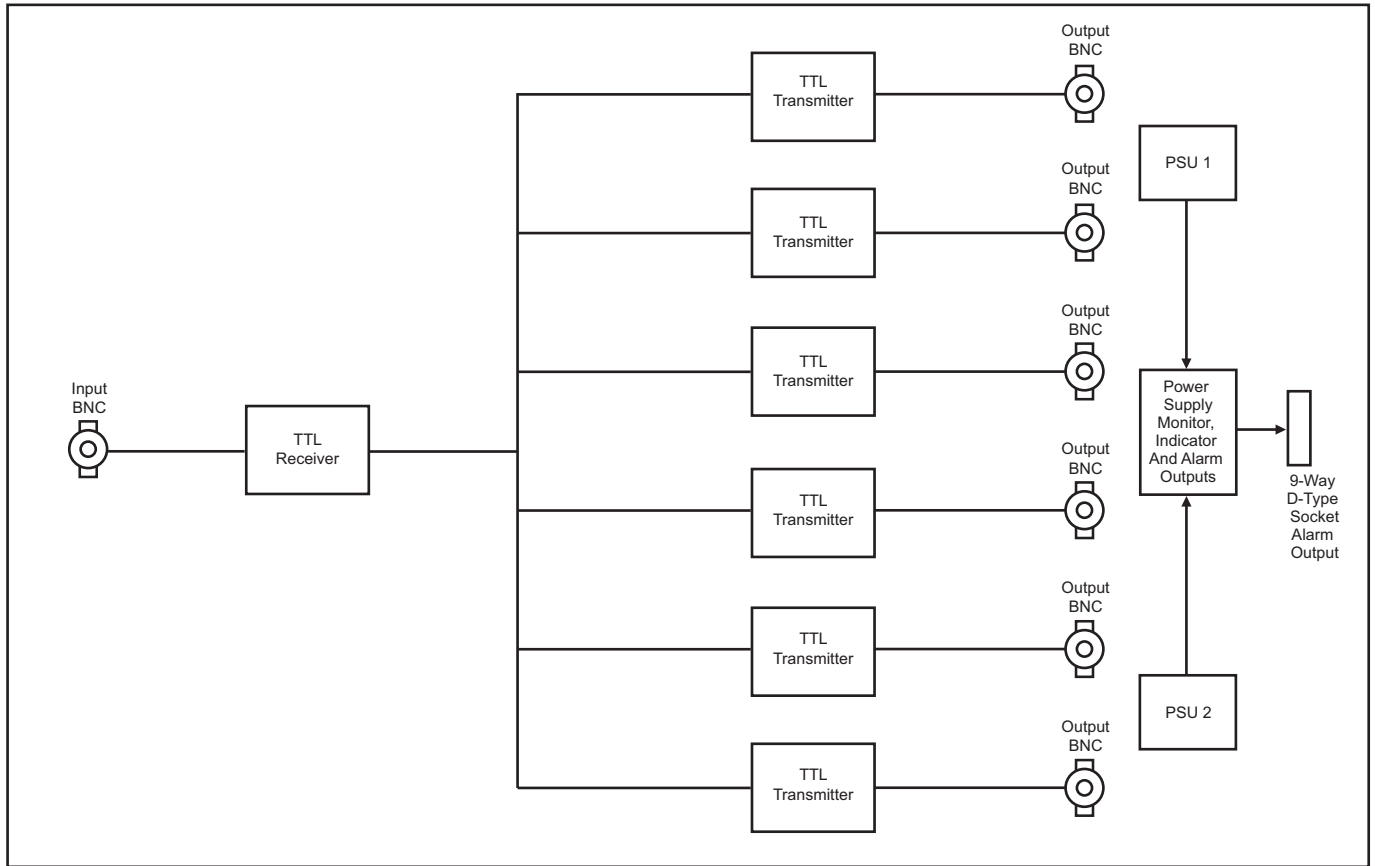

Fig 13-2: RB-DDA6W-2P System Block Diagram

## Rear Panel Connections and Operations

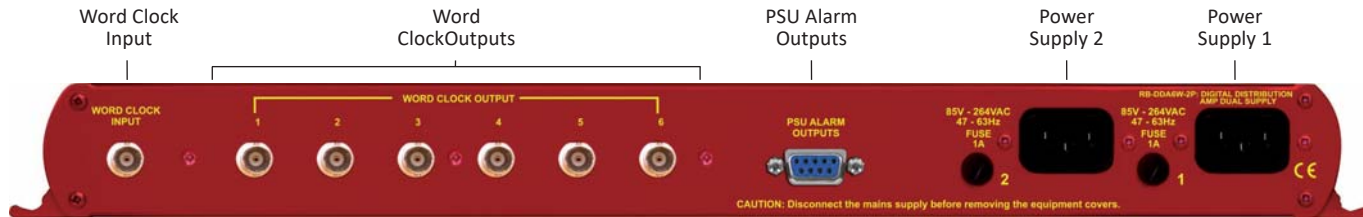

Fig 13-3: RB-DDA6W-2P Rear Panel

### Word Clock Input

The Word Clock BNC input has an impedance of 75Ω.

### Word Clock Outputs

The Word Clock BNC outputs have an impedance of <75 Ω.

### Alarm Connector

Pin 1: Power Supply 1 Common

Pin 2: Power Supply 1 Normally Open

Pin 3: Ground

Pin 4: Power Supply 2 Common

Pin 5: Power Supply 2 Normally Open

Pin 6: Power Supply 1 Normally Closed (indicates supply inactive)

Pin 7: Ground

Pin 8: Ground

Pin 9: Power Supply 2 Normally Closed (indicates supply inactive)

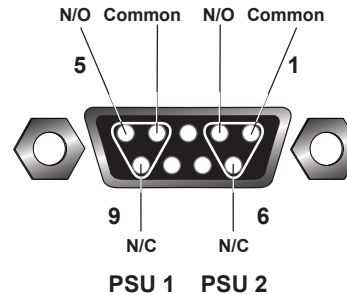

Fig 13-4: RB-DDA6W-2P Alarm Connector Diagram

## Technical Specification For RB-DDA6W-2P

### Audio Specification

Input impedance: 75Ω

Output impedance: <75Ω

### Connections

Audio Inputs: 1 x BNC female

Audio Outputs: 6 x BNC female

Alarm Outputs: 2 x Relay output indicators on 1 x 9 pin D-Type socket

Mains Input: 2 x Filtered IEC, 85-264V switchable, fused, 6W max

Fuse Rating: 2 x Anti-surge fuse 1A 20 x 5mm

### Equipment Type

RB-DDA6W-2P:  6 way word clock distribution amplifier with dual power supplies

### Physical Specification

Dimensions (Raw): 48cm (W) x 10.8cm (D) x 4.2cm (H) (1U)  
19" (W) x 4.3" (D) x 1.7" (H) (1U)

Dimensions (Boxed): 58.5cm (W) x 22.5cm (D) x 7cm (H)  
23" (W) x 8.9" (D) x 2.8" (H)

Weight: Nett: 1.5kg Gross: 2.0kg  
Nett: 3.3lbs Gross: 4.4lbs

# 14 RB-DDA22 Digital Audio Distribution Amplifier With Multiple Outputs

## Introduction



Fig 14-1: RB-DDA22 Front Panel

The RB-DDA22 digital distribution amplifier is used for distributing digital audio data in many formats, repeating both the audio data and the status information of the input whilst re-clocking the data and re-normalising to the appropriate standard digital audio levels.

The unit has 5 inputs and you can select one of them to distribute to all of the 22 outputs.

### Input Signals:

- 1 x XLR 3 female AES/EBU digital audio input
- 1 x BNC AES-3id digital audio input
- 1 x RJ45 AES/EBU digital audio input
- 1 x RCA Phono S/PDIF input
- 1 x TOSLink digital audio optical input

### Output Signals:

- 6 x XLR-3 male AES/EBU digital audio outputs
- 6 x BNC AES-3id digital audio outputs
- 6 x RJ45 AES/EBU digital audio outputs
- 2 x RCA Phono S/PDIF outputs
- 2 x TOSLink optical outputs

The RJ-45 connectors are wired to be StudioHub+ compatible, a format defined by Radio Systems Inc.

*StudioHub+™ is a registered trademark of Radio Systems Inc*

Applications include distributing audio from a digital mixing desk to multiple digital recorders, or feeding multiple studios with an output from a USB audio player.

It can accept input sample rates in the range of 30kHz - 200kHz, and bit rates of 16, 20 and 24 bit. So, it can be used for standard CD signal distribution at 16 bit 44.1kHz, as well as for high quality 24 bit 96kHz or 192kHz recording.



Fig 14-2: RB-DDA22 Front Panel Controls

The front panel has an INPUT SELECT button and 7 indicator LEDs. The button is used to select the input to be used and shows the mode of operation of the unit. The LEDs will indicate, depending on the mode of operation, the input selected,

valid signal presence, or the operational frequency.

### Operating Mode

In 'operating mode', the central button LED is unlit. The unit selects this mode when a valid input signal has been present and no button presses have been made for 8 seconds. The LEDs around the button illuminate amber to directly indicate the following frequencies 32, 44.1, 48, 88.2, 96,

176.4 & 192 kHz. If the input is at a non-standard frequency then the unit will indicate both the frequencies either side of the incoming frequency – e.g. if the input signal has a frequency of 64kHz then both the 48kHz and 88.2kHz LEDs will be illuminated. If the frequency is below 32kHz or above 192kHz then the appropriate LED will flash.

**Input Select Mode**

Pressing the INPUT SELECT central button illuminates it red and allows you to select the required input. Pressing the button will step the selected input to the next input selection including auto mode.

In Input Select Mode the LEDs have the following states:

Off – Signal not selected and no valid signal present

Green – Signal not selected and valid signal present

Red – Signal selected and no valid signal present

Amber – Signal selected and valid signal present or Auto Mode Selected

Note: Input Select mode is chosen automatically when the selected input is not present.

**Auto Select Mode**

In this special input select mode the unit will hunt through all the inputs until it finds a valid signal. If multiple signals are present you can force selection of the next input by holding the input select button down for 2 seconds, when the next valid input will be selected.

**System Block Diagram**

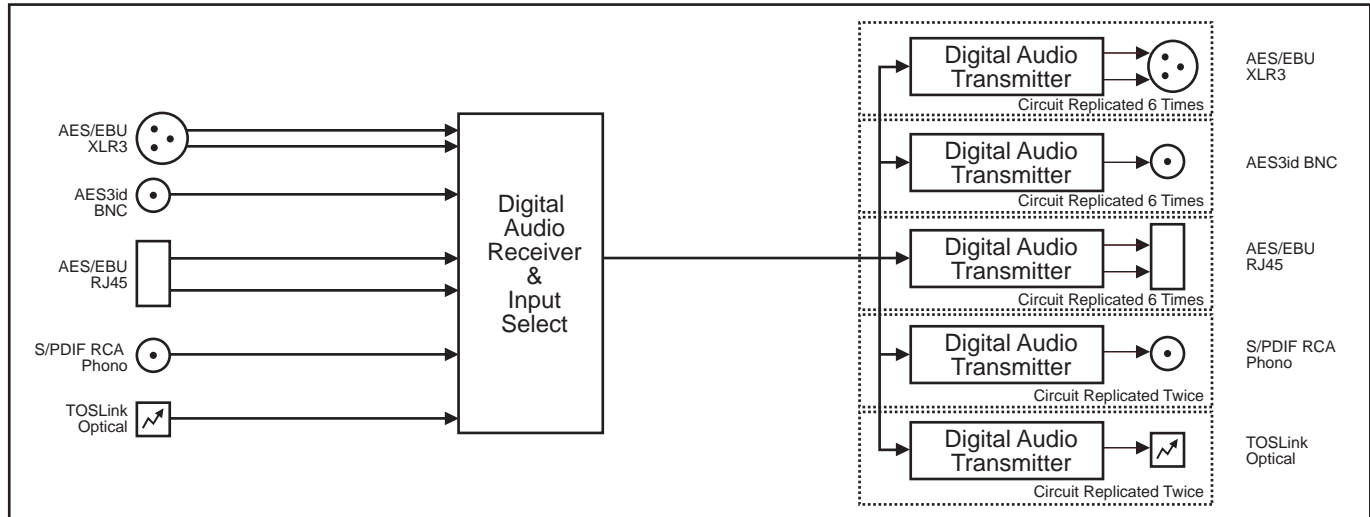

Fig 14-3: RB-DDA22 System Block Diagram

## Rear Panel Connections and Operations



Fig 14-4: RB-DDA22 Rear Panel

### Digital Audio Inputs

#### AES/EBU Inputs

The XLR 3 pin socket has an impedance of 110Ω. It has the following connections:

- Pin 1: Screen
- Pin 2: Phase
- Pin 3: Non-phase

The BNC AES3id input has an impedance of 75Ω.

The RJ45 AES input has an impedance of 110Ω. It has the following connections:

- Pin 1: Phase
- Pin 2: Non-phase
- Pin 3: No Connection
- Pin 4: Screen
- Pin 5: No Connection
- Pin 6: No Connection
- Pin 7: No Connection
- Pin 8: No Connection

#### S/PDIF Input

The S/PDIF phono input has an impedance of 75Ω.

### Optical Input

The optical input is a standard TOSLink connector.

### Digital Audio Outputs

#### AES/EBU Outputs

The XLR 3 pin sockets have an impedance of 110Ω. They have the following connections:

- Pin 1: Screen
- Pin 2: Phase
- Pin 3: Non-phase

The BNC AES3id outputs have an impedance of 75Ω.

The RJ45 AES outputs have an impedance of 110Ω. They have the following connections:

- Pin 1: Phase
- Pin 2: Non-phase
- Pin 3: No Connection
- Pin 4: Screen
- Pin 5: No Connection
- Pin 6: No Connection
- Pin 7: No Connection
- Pin 8: No Connection

**S/PDIF Outputs**

The S/PDIF phono outputs have an impedance of 75Ω.

**Optical Outputs**

The optical outputs are standard TosLink connectors.

**Technical Specifications RB-DDA22****Audio Specifications**

Sample Frequency Range: 30-200kHz (i.e. including 32kHz, 44.1kHz, 48kHz, 88.2kHz, 96kHz, 176.4kHz and 192kHz)

Bit Depth: Up to and including 24 bit

Input Impedance: AES/EBU or RJ45: 110Ω ± 20% balanced  
AES BNC: 75Ω ± 20% unbalanced  
S/PDIF: 75Ω ± 5% unbalanced

Input Signal Level: AES/EBU or RJ45: 3V/10V peak to peak min/max  
AES/BNC: 1.0V ± 20% min  
S/PDIF: 0.5V ± 20% min

Output Impedance: AES/EBU or RJ45: 110Ω ± 20% balanced  
AES BNC: 75Ω ± 20% unbalanced  
S/PDIF: 75Ω ± 5% unbalanced

Input Signal Level: AES/EBU or RJ45: 3V/10V peak to peak min/max  
AES/BNC: 1.0V ± 20% min  
S/PDIF: 0.5V ± 20% min

**Front Panel Operational Controls & Indicators**

Digital Input Select: AES/EBU (XLR), AES/EBU (BNC), AES/EBU (RJ45), S/PDIF or TosLink optical

Indicators: Input presence and sample rate being used indicators via tricolour LEDs around the input select button

**Connections**

Inputs: 1 x AES/EBU XLR 3 pin female (balanced)  
1 x AES3id BNC (unbalanced)  
1 x AES StudioHub+TM RJ45 (balanced)  
1 x S/PDIF RCA phono female (unbalanced)  
1 x TosLink optical receiver

Outputs: 6 x AES/EBU XLR 3 pin male (balanced)  
6 x AES3id BNC male (balanced)  
6 x AES StudioHub+ TM RJ45 (balanced)  
2 x S/PDIF RCA phono female (unbalanced)  
2 x TosLink optical transmitter

Mains Input: Filtered IEC, 85-264VAC 47-63Hz, fused, 10W max

Fuse Rating: Anti-surge fuse 1A 20 x 5mm

**Equipment Type**

RB-DDA22:  Digital audio distribution amplifier with multiple outputs

**Physical Specifications**

Dimensions (Raw): 48cm (W) x 10.8cm (D) x 4.2cm (H) (1U)  
19" (W) x 4.3" (D) x 1.7" (H) (1U)

Dimensions (Boxed): 58.5cm (W) x 22.5cm (D) x 7cm (H)  
23" (W) x 8.9" (D) x 2.75" (H)

Weight: Nett: 1.4kg Gross: 2.0kg  
Nett: 3.0lbs Gross: 4.4lbs

## 15 RB-AES4B3 Quad 3 Way Passive AES-3id Splitters With BNC Connectors

### Introduction



Fig 15-1: RB-AES4B3 Front Panel

The RB-AES4B3 is a passive digital splitter, designed to split a single AES-3id source to up to three destinations, using BNC connectors. 75 $\Omega$  termination can be applied, if desired to unconnected outputs. The RB-AES4B3 is a quad “one-to-three” splitter housed in a 19” rack.

### Block Diagram

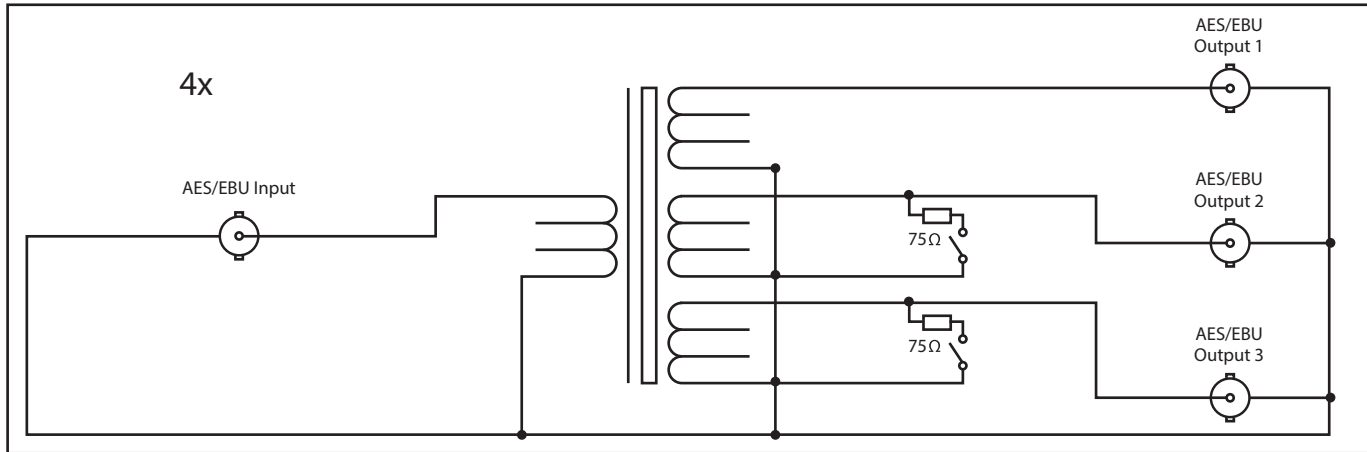

Fig 15-2: RB-AES4B3 System Block Diagram

## Controls & Connectors

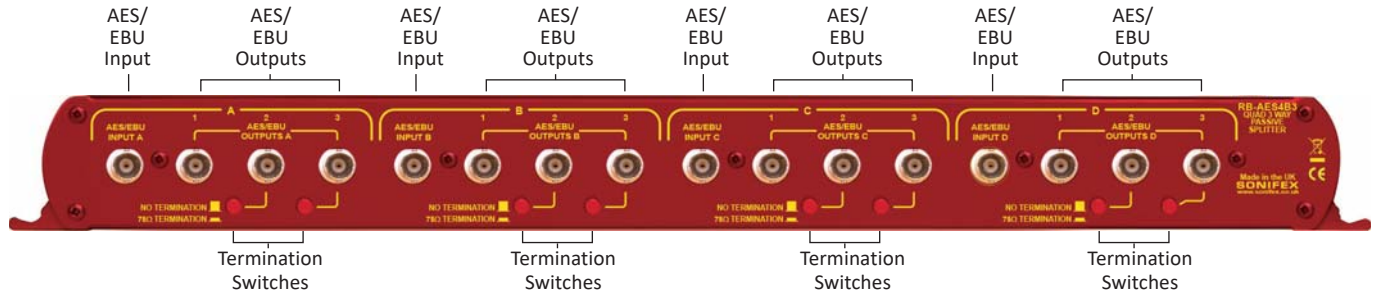

Fig 15-3: RB-AES4B3 Front Rear Panel

### AES/EBU input(s)

The single digital audio input is via a female BNC connector with the following pin assignment:

Tip: Signal

Screen: 0V Common

### AES/EBU outputs 1-3

The digital audio outputs are via a female BNC connectors with the following pin assignment:

Tip: Signal

Screen: 0V Common

### Termination switches

It is possible to terminate Output 2 and Output 3 with 75Ω in the event that they are not connected to a destination device. It may be necessary to remove termination from an unused output if a used output is connected to a destination via a long cable run, in order to increase the level of the AES-3id carrier signal.

## Technical Specification RB-AES4B3

### Cable drive capability

Cumulative cable drive capability of 100m of 75Ω coaxial cable at sample rates up to and including 96kHz.

### Equipment Type

RB-AES4B3



Quad 3 Way Passive Digital AES-3id Splitters, with BNC connections in a 19" rack.

### Physical Specification

Dimensions (Raw): 48cm (W) x 10.8cm (D) x 4.2cm (H)(1U)  
19" (W) x 4.3" (D) x 1.7" (H) (1U)

Dimensions (Boxed): 58.5cm (W) x 22.5cm (D) x 7cm (H)  
23" (W) x 8.9" (D) x 2.8" (H)

Weight: Nett: 1.02kg Gross: 1.38kg  
Nett: 2.25lbs Gross: 3.04lbs

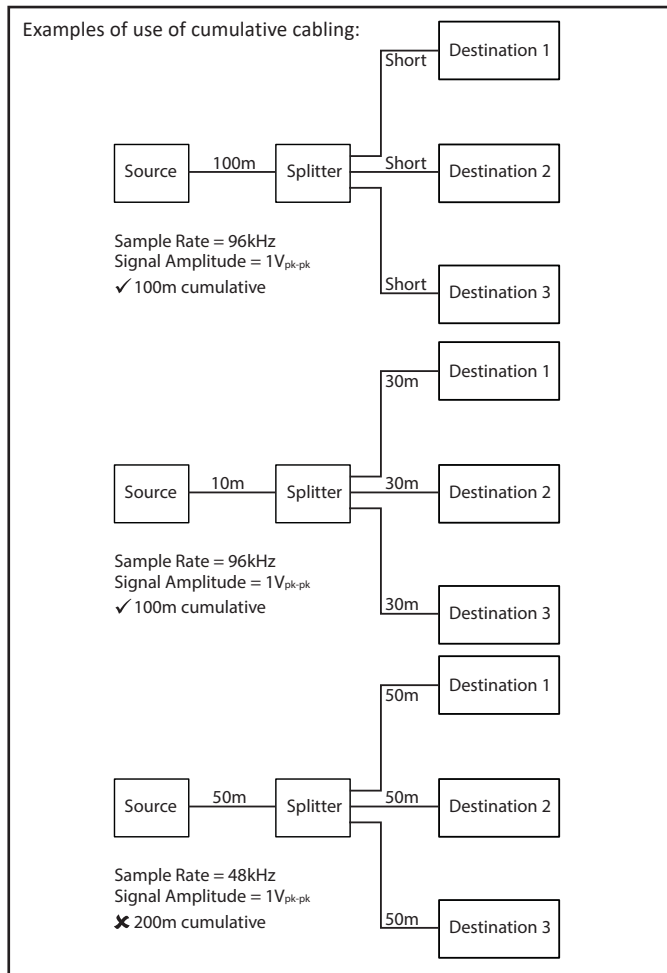

Fig 15-4: RB-AES4B3 Examples Of Cumulative Cabling

## 16 RB-AES4X3 Quad 3 Way AES3 Splitter XLR Connectors

### Introduction



Fig 16-1: RB-AES4X3 Front Panel

The RB-AES4X3 is a passive digital splitter, designed to split a single AES3 source to up to three destinations, using Neutrik XLR connectors.  $110\Omega$  termination can be applied, if desired to unconnected outputs. The RB-AES4X3 is a quad “one-to-three” splitter housed in a 19” rack.

### Block Diagram

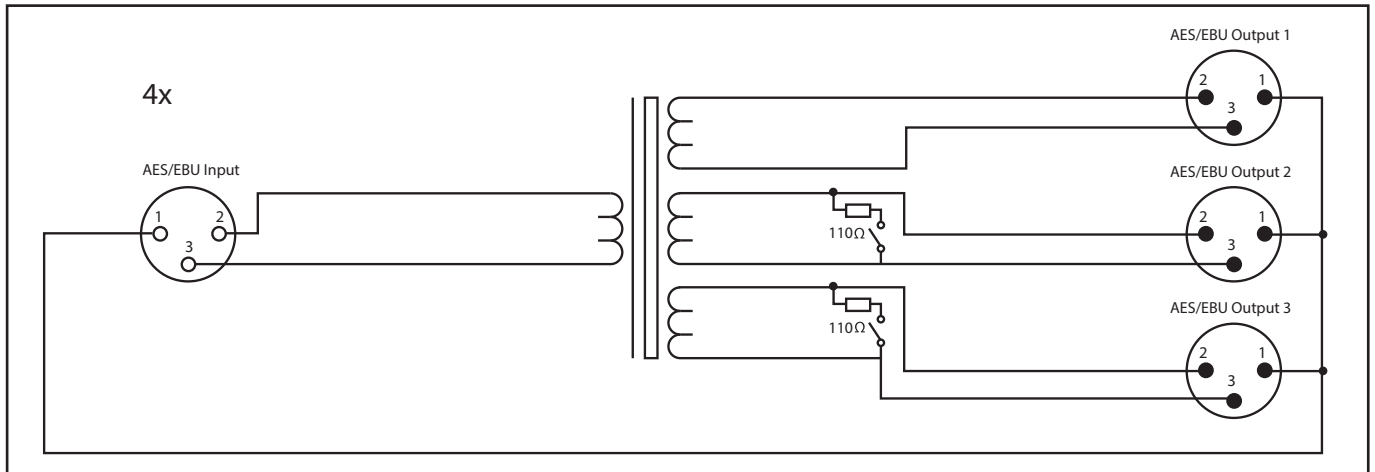

Fig 16-2: RB-AES4X3 System Block Diagram

## Controls & Connectors

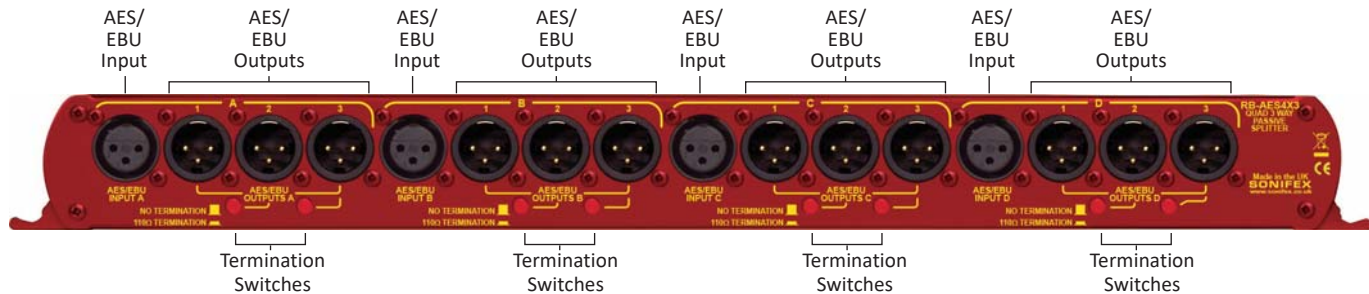

Fig 16-3: RB-AES4X3 Rear Panel

### AES/EBU input(s)

The single digital audio input is via a female XLR connector with the following pin assignment:

- Pin 1: 0V Common
- Pin 2: Phase
- Pin 3: Non Phase

### AES/EBU outputs 1-3

The digital audio outputs are via male XLR connectors with the following pin assignment:

- Pin 1: 0V Common
- Pin 2: Phase
- Pin 3: Non Phase

### Termination switches

It is possible to terminate Output 2 and Output 3 with 110Ω in the event that they are not connected to a destination device. It may be necessary to remove termination from an unused output if a used output is connected to a destination via a long cable run, in order to increase the level of the AES3 carrier signal.

## Technical Specifications RB-AES4X3

### Cable drive capability

The table below sets out the minimum signal amplitude required to drive 100m (cumulative) of 110Ω twisted pair cable, based on the sample rate of the digital audio:

Sample Rate	Minimum Signal Amplitude
32kHz	*2Vpk-pk
44.1kHz	*2Vpk-pk
48kHz	*2Vpk-pk
88.2kHz	5Vpk-pk
96kHz	5Vpk-pk

\* Minimum of 2Vpk-pk is defined by the AES3 format specification.

The table below sets out the minimum signal amplitude required to drive 30m (cumulative) of 110Ω twisted pair cable, based on the sample rate of the digital audio:

Sample Rate	Minimum Signal Amplitude
176.4kHz	3Vpk-pk
192kHz	3Vpk-pk

### Equipment Type

RB-AES4X3  Quad 3 Way Passive Digital AES3 Splitters, with XLR connections in a 19" rack.

### Physical Specification

Dimensions (Raw): 48cm (W) x 10.8cm (D) x 4.2cm (H)(1U)  
19" (W) x 4.3" (D) x 1.7" (H) (1U)

Dimensions (Boxed): 58.5cm (W) x 22.5cm (D) x 7cm (H)  
23" (W) x 8.9" (D) x 2.8" (H)

Weight: Nett: 1.02kg Gross: 1.38kg  
Nett: 2.25lbs Gross: 3.04lbs

Examples of use of cumulative cabling:

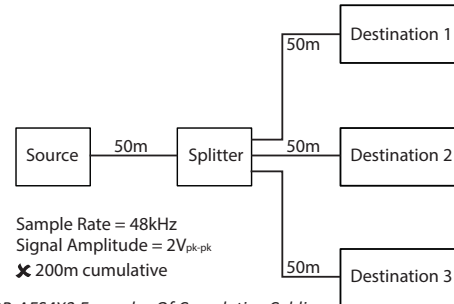
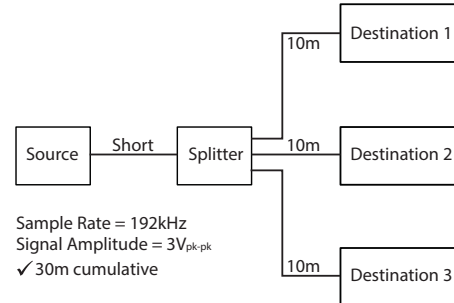
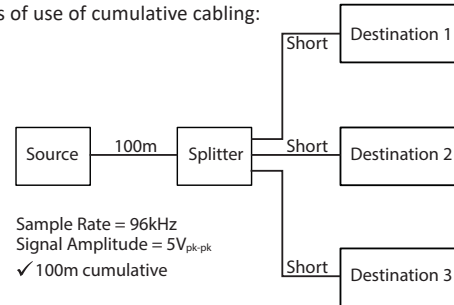

Fig 16-4: RB-AES4X3 Examples Of Cumulative Cabling

# 17 RB-MS4X3 Quad 3 Way Microphone Splitter

## Introduction



Fig 17-1: RB-MS4X3 Front Panel

Controls x 4

The RB-MS4X3 is a passive microphone splitter, designed to split the signal from a single mic or line source, to up to 3 destinations, whilst allowing the operator to pass phantom power back from mic preamplifier inputs, or apply +48VDC power directly from the unit. Pin 1 “ground” lifts are provided to eliminate ground loop problems.

## Block Diagram

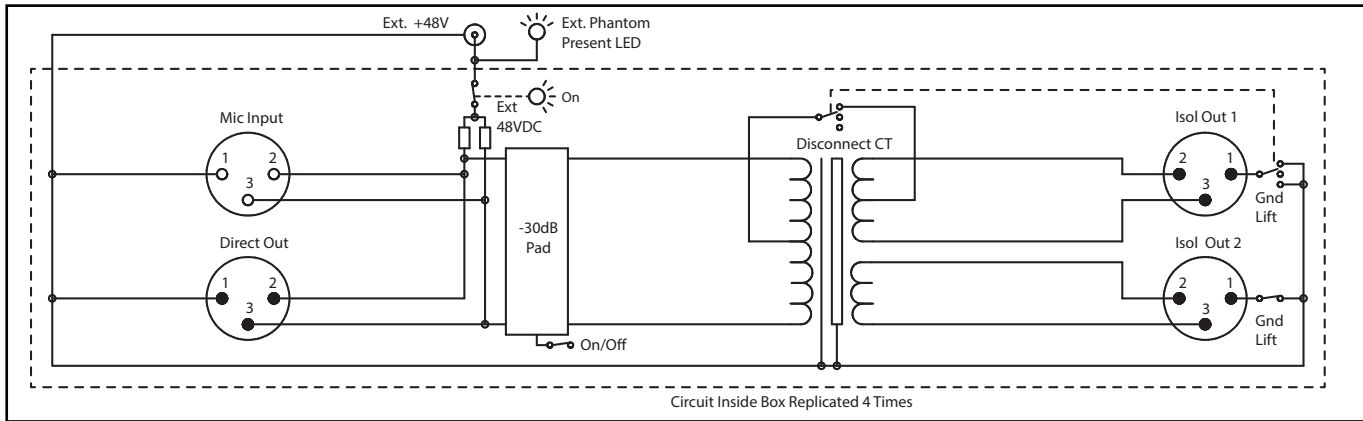

Fig 17-2: RB-MS4X3 System Block Diagram

## Controls & Connectors Front Panel

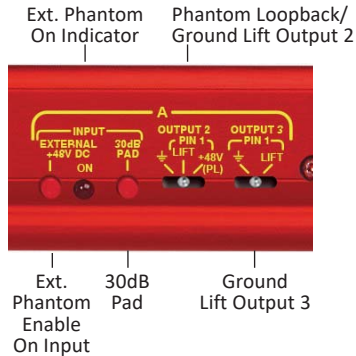

Fig 17-3: RB-MS4X3 Front Panel Connections

### External +48VDC

This latching push switch applies the external +48V phantom power (if connected) to a microphone connected to the rear panel input connector.

### ON LED

The ON LED illuminates when both external +48V phantom power is connected to the rear panel DC socket and the external power is switched to the input.

### 30dB Pad

It is possible to attenuate the incoming signal by 30dB for example when interfacing a line level signal into a microphone preamplifier. The latching push switch applies and removes the 30dB pad.

**Important:** Phantom power should be disabled when connecting a line level signal to the splitter input.

### Output 2 Toggle switch

This switch controls both the grounding of the output 2 XLR connector (pin 1) and the ability to pass back phantom power (via the internal transformer's centre tap) from output 2 to a mic connected to the splitter's input.

Switch Position	Phantom Loopback (PL)	Output 2 XLR Pin 1
Left	Disabled	Grounded
Centre	Disabled	Lifted
Right	Enabled	Grounded

### Output 3 Toggle Switch

This switch controls the grounding of the output 3 XLR connector.

Switch Position	Phantom Loopback (PL)
Left	Grounded
Right	Lifted

### Phantom Powering Guidance

It is possible to pass phantom power to the splitter input by three different methods:

- Via the external +48V DC connector.
- From a mic pre-amp connected to direct output (output 1).
- From a mic pre-amp connected to output 2 (provided phantom loopback is enabled).

It is therefore possible to concurrently power the microphone using any two of the above methods (for power redundancy) without causing signal degradation. It is important the output connectors are grounded (and not lifted) should the external phantom power be connected, to prevent hum/hiss caused by ground loop currents.

**Important:** A maximum of two phantom powering methods can be used concurrently.

## Rear Panel

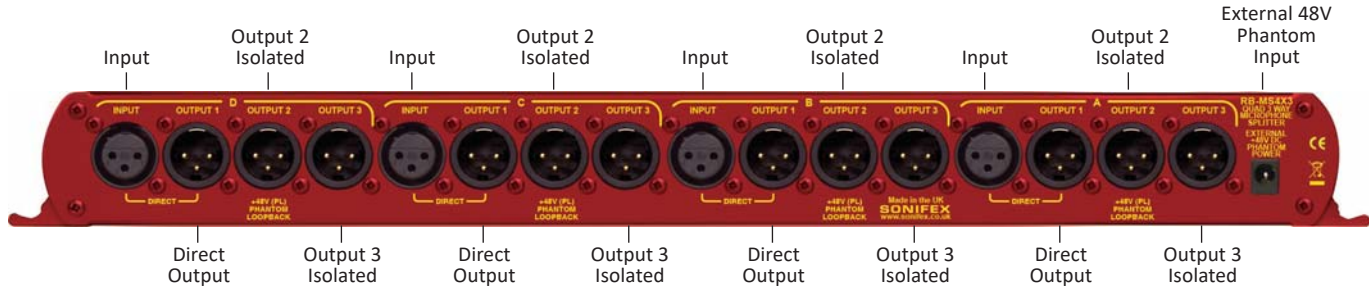

Fig 17-4: RB-MS4X3 Rear Panel Connections

### Input

The XLR 3 pin input socket is transformer balanced and is capable of accepting a dynamic or phantom powered microphone, or a line level signal up to +18dBu (without the 30dB pad applied). The input socket has the following connections:

- Pin 1: Screen
- Pin 2: Phase
- Pin 3: Non Phase

### Output 1 (Direct)

The XLR 3 pin plug is a parallel connection of the input. It is therefore possible to supply phantom power to the splitter input by connecting output 1 to a phantom powered microphone preamplifier. The output 1 plug has the following connections:

- Pin 1: Screen
- Pin 2: Phase
- Pin 3: Non Phase

### Output 2 (+48V PL Phantom Loopback)

The XLR 3 pin plug is a transformer isolated output. A switchable centre tap connection makes it possible to supply phantom power to the splitter input by connecting output 2 to a phantom powered microphone preamplifier, and setting the front panel toggle switch to the correct position (see front panel controls). The output 2 plug has the following connections:

- Pin 1: Screen (Can be grounded or lifted by front panel toggle switch)
- Pin 2: Phase
- Pin 3: Non Phase

### Output 3

The XLR 3 pin plug is a transformer isolated output and has the following connections:

- Pin 1: Screen (Can be grounded or lifted by front panel toggle switch)
- Pin 2: Phase
- Pin 3: Non Phase

### Technical Specifications RB-MS4X3

Test	Conditions	Result
Frequency Response	Ref. -6dBu, 1kHz Source Impedance = 150Ω Load Impedance = 10kΩ	10Hz - 30kHz ±0.5dB
Total Harmonic Distortion	Ref. +3dBu, 50Hz Source Impedance = 150Ω Load Impedance = 10kΩ	0.02%
Total Harmonic Distortion 0.1%	Ref. 0.1%THD+N, 50Hz Source Impedance = 150Ω Load Impedance = 10kΩ	+13dBu
Total Harmonic Distortion 1%	Ref. 1%THD+N, 50Hz Source Impedance = 150Ω Load Impedance = 10kΩ	+18dBu
Common Mode Rejection Ratio	Ref. 20kHz Source Impedance = 600Ω Load Impedance = 10kΩ	>60dB

**Equipment Type**  
 RB-MS4X3  Quad 3 Way Microphone Splitter.

**Physical Specification**  
 Dimensions (Raw): 48cm (W) x 10.8cm (D) x 4.2cm (H)(1U)  
 19" (W) x 4.3" (D) x 1.7" (H) (1U)  
 Dimensions (Boxed): 58.5cm (W) x 22.5cm (D) x 7cm (H)  
 23" (W) x 8.9" (D) x 2.8" (H)  
 Weight: Nett: 1.02kg Gross: 1.38kg  
 Nett: 2.25lbs Gross: 3.04lbs

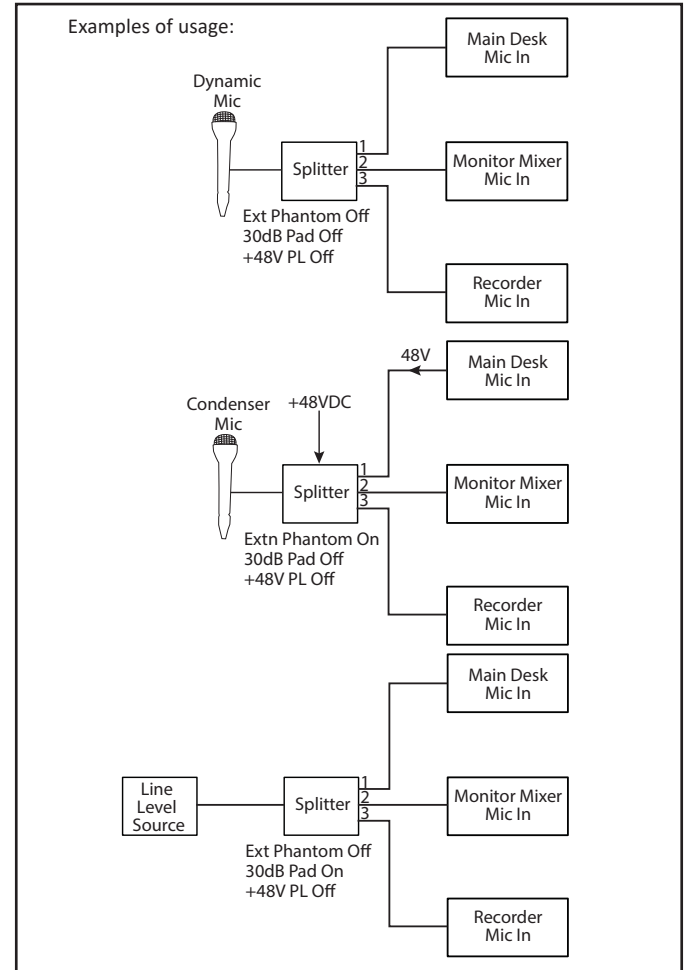

Fig 17-5: RB-MS4X3 Examples Of Usage

## 18 RB-MSP6 6 Way +48V Phantom Power Supply

### Introduction



Fig 18-1: RB-MSP6 Front Panel

The RB-MSP6 is a 1U rack-mount phantom power supply, designed to be used in conjunction with up to six RB-MS4X3s, providing mains input redundancy to ensure the target microphones remain powered in the event of a single mains failure.

Two mains AC inlets power separate 48V supplies that are diode fed to six locking DC connector outputs. Each output connector is individually

protected with a resettable fuse rated at 50mA, so a fault on one output will not affect the others.

Should either of the 48V supplies fail, or if their AC power input is removed, the corresponding red front panel LED will extinguish, and a relay alarm output is provided on the rear panel D-Type.

### System Block Diagram

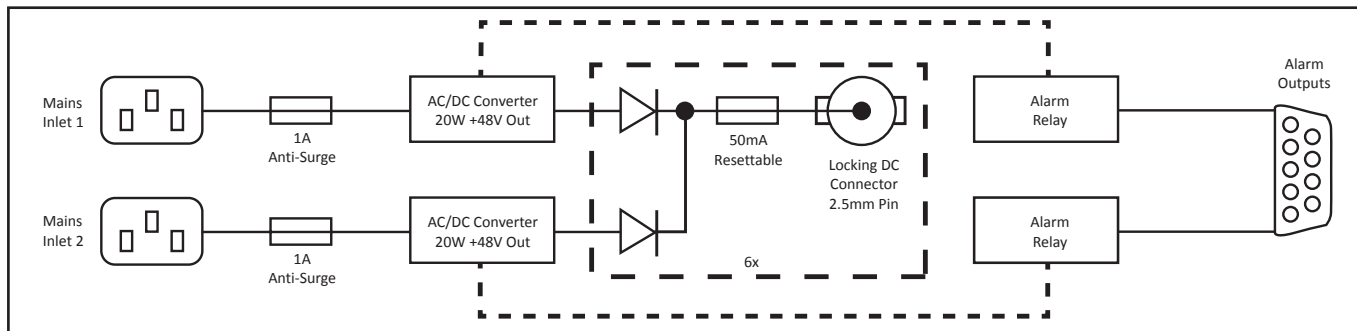

Fig 18-2: RB-MSP6 System Block Diagram

## Connections and Operation

### Front Panel Controls and Indicators



Fig 18-3: RB-MSP6 Front Panel LED Indicators

The RB-MSP6 front panel LEDs (labelled 1 and 2) show the presence of power at the input of each IEC AC supply. Each LED illuminates red if power is present at the input. If a LED extinguishes, it indicates a problem with the corresponding supply. This could be due to one or more of the following:

- The AC mains input is out of range or missing.
- The mains fuse is blown or missing.
- The internal AC/DC 48V supply is faulty.

The current status of the two AC/DC 48V power supplies is also reflected at the remote output port on the rear panel, see below for details.



Fig 18-4: RB-MSP6 Rear Panel Connections

## Rear Panel Connections

### AC Mains inputs

The two mains inputs should be connected to 90V – 264V, 47 – 63Hz AC mains supplies, and protected with a 1A anti-surge fuse.

### +48V Phantom Power Outputs

The DC outputs each provide up to 50mA of phantom power (48V) to an externally connected RB-MS4X3. The connectors are locking to prevent accidental unplugging, and the positive voltage is on the 2.5mm centre pin.



### Alarm Outputs (ALARMS)

The 9 way D-Type socket contains alarm outputs that monitor the status of the two 48V power supplies. A changeover relay provides a normally open (NO), normally closed (NC) and a common connection for each supply. The pinout of the D-Type connector is shown below.

**Note:** “Normally closed” refers to the pin that is connected to the common when the corresponding supply is working normally.

Pin Number	Connection
1	Supply 1 Normally Open (NO)
2	Supply 1 Common
3	Supply 1 Normally Closed (NC)
6	Supply 2 Normally Open (NO)
7	Supply 2 Common
8	Supply 2 Normally Closed (NC)
4,5,9	No Connection

**Example:**

The diagram below shows a fault scenario where the mains connection to Supply 2 has been unplugged. The front panel LED is no longer illuminated, and the relay has switched, creating a connection between pins 6 and 7 of the ALARMS D-Type.

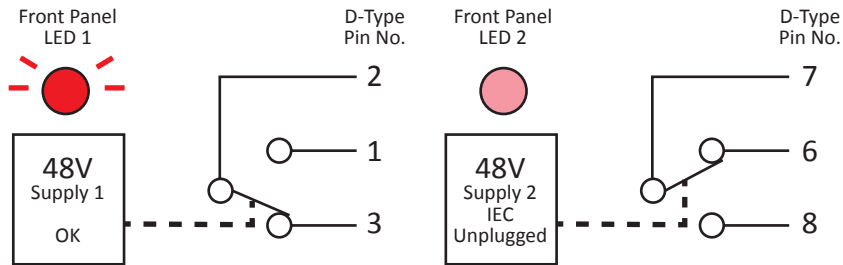

Fig 18-5: RB-MSP6 Fault Scenario Diagram

**Technical Specifications RB-MSP6**

Mains inputs	2 x Filtered IEC, 90V-264V, 47-63Hz, fused, 20W maximum
Fuse Ratings	2 x Anti-surge fuse 1A 20 x 5mm
Phantom Power Outputs	6 x locking DC connectors, 2.5mm pin, 48VDC, 50mA maximum current, protected by resettable fuse.

**Equipment Type:**

RB-MSP6:  RB-MSP6 6 way phantom power supply

**Physical Specification:**

Dimensions (Raw):	28cm (W) x 10.8cm (D) x 4.2cm (H) (1U) 11" (W) x 4.3" (D) x 1.7" (H) (1U)
Dimensions (Boxed):	36cm (W) x 20.5cm (D) x 6cm (H) 14.2" (W) x 8" (D) x 2.4" (H)
Weight:	Nett: 1.14kg Gross: 1.52kg Nett: 2.50lbs Gross: 3.34lbs

**Accessories:**

RB-RK2: 1U rear panel rack kit for small Redbox range



**SONIFEX**

[www.sonifex.co.uk](http://www.sonifex.co.uk)

t:+44 (0)1933 650 700

f:+44 (0)1933 650 726

[sales@sonifex.co.uk](mailto:sales@sonifex.co.uk)