



HANDBOOK

## Redbox User Handbook No 2

<b>RB-SD1</b>	Silence Detection Unit
<b>RB-SD1IP</b>	Silence Detection Unit With Ethernet & USB
<b>RB-DSD1</b>	Digital Silence Detection Unit
<b>RB-DSD8</b>	8 Channel Silence Switcher
<b>RB-FS42</b>	Audio Failover Switcher, 4 Main I/O, 2 Standby I/O
<b>RB-FS42DC</b>	Audio Failover Switcher, 4 Main I/O, 2 Standby I/O, DC PSU
<b>RB-FS82</b>	Audio Failover Switcher, 8 Main I/O, 2 Standby I/O
<b>RB-FS82DC</b>	Audio Failover Switcher, 8 Main I/O, 2 Standby I/O, DC PSU



Manufacturers of audio & video  
products for radio & TV broadcasters

**SONIFEX**

For the latest Sonifex handbook information please visit the  
Sonifex website at [www.sonifex.co.uk](http://www.sonifex.co.uk)

This handbook is for use with the following product:

Redbox User Handbook No 2

Stock Code: 30-337

Artwork: AW10839A

Revision 3.04, September 2018

©Sonifex Ltd, 2018

All Rights Reserved

Sonifex Ltd, 61, Station Road, Irthlingborough,  
Northants, NN9 5QE, England.

Tel: +44 (0)1933 650 700

Fax: +44 (0)1933 650 726

Email: [sales@sonifex.co.uk](mailto:sales@sonifex.co.uk)

Website: <http://www.sonifex.co.uk>

Information in this document is subject to change without notice and does not represent a commitment on the part of the vendor. Sonifex Ltd shall not be liable for any loss or damage whatsoever arising from the use of information or any error contained in this manual.

No part of this manual may be reproduced or transmitted in any form or by any means, electronic or mechanical, including photocopying, recording, information storage and retrieval systems, for any purpose other than the purchaser's personal use, without the express written permission of Sonifex Ltd. Unless otherwise noted, all names of companies, products and persons contained herein are part of a completely fictitious adaptation and are designed solely to document the use of Sonifex product.

Made in the UK by **SONIFEX**

# Contents

## Product Warranty - 2 Year Extended

### Sonifex Warranty & Liability Terms & Conditions

1. Definitions
2. Warranty

### Unpacking Your Product

### Repairs & Returns

## CE Conformity

## Safety & Installation of Mains Operated Equipment

### Voltage Setting Checks

### Fuse Rating

### Power Cable & Connection

### WEEE Directive

### Atmosphere/Environment

### Fitting Redboxes

## 1 RB-SD1 Silence Detection Unit

### Introduction

### System Block Diagram

### Rear Panel Connections and Operation

### Front Panel Selectors and Indicators

- Source Select and Indicator

### Additional Modes

### Technical Specifications RB-SD1

## 2 RB-SD1IP Silence Detection Unit With Ethernet & USB

### Introduction

### System Block Diagram

### Rear Panel Connections and Operation

- Mode DIP Switch Settings
- Remote Alarms Connector

### Front Panel Selectors and Indicators

### RB-SD1IP Network Discovery and Webserver

- Sonifex Service Discovery App

### Home Page

### Device Information

### Network Settings

### Configuration : Level & Time Settings

### Configuration : Source Settings

### Configuration : Alarm Settings

### Configuration : SNMP Settings

### Configuration : USB Settings

### Configuration : Remote Settings

### Configuration : GPIO Settings

### Configuration : Physical Settings

### Update

### Technical Specification RB-SD1IP

## 3 RB-DSD1 Digital Silence Detection Unit

### Introduction

### Front Panel Controls and Indicators

### Front Panel DIPSwitches

### Rear Panel Controls

### Remotes Connector

### RB-DSD1 Inputs & Outputs

### Serial Port Control

- Serial Interface Commands and Responses

- Serial Protocol RB-DSD1

### SCi for RB-DSD1

- Indication Page

- Unit Setup Page

- Miscellaneous Page

### Special Modes

### Technical Specification For RB-DSD1

## 4 RB-DSD8 8 Channel Silence Switcher

### Front Panel Controls & Indicators

- Status Buttons

- DISPLAY LEDS

### Rear Panel DIPSwitch Settings

### RB-DSD8 Rear Panel Connections

### Audio Connections

- GPIO Remotes Connector

- Alarm Output Pins

- Control Inputs

- Slave Socket

- USB Remote Control

### Ethernet

### Wordclock & AES Synchronisation Input

### Dual IEC Main Inputs

### Remote Control

- Slave Control

### Serial Interface Commands & Responses

- Error Messages

29

30

31

32

33

34

34

36

37

38

41

42

43

43

43

46

47

48

49

50

51

53

55

55

55

58

61

61

62

63

63

64

64

64

64

64

65

65

65

65

68

<b>SCI for RB-DSD8</b>	<b>68</b>	<b>Network Discovery &amp; Webserver Configuration</b>	<b>110</b>
Status Page	68	Device Info	114
Channel Status Page	70	Home Page	115
Miscellaneous Page	71	Network Settings	116
<b>Webserver</b>	<b>72</b>	SNMP	117
Connecting to the device	73	Channel Settings	118
Webserver Password	73	Power Supply Trap Settings	119
<b>Updating The Firmware</b>	<b>74</b>	GPO Settings	120
<b>Technical Specification RB-DSD8</b>	<b>75</b>	LED Settings	121
<b>5 RB-FS42 Audio Failover Switcher, 4 Main I/O, 2 Standby I/O</b>	<b>77</b>	Update	122
<b>Introduction</b>	<b>77</b>	<b>Technical Specifications RB-FS82</b>	<b>123</b>
<b>Connections &amp; Operation</b>	<b>80</b>		
<b>Front Panel</b>	<b>80</b>		
<b>Rear Panel Connections</b>	<b>82</b>		
25 Way D-Type Connection Details	83		
<b>Typical Application</b>	<b>85</b>		
<b>Network Discovery &amp; Webserver Configuration</b>	<b>86</b>		
Device Info	90		
Home Page	91		
Network Settings	92		
SNMP	93		
Channel Settings	94		
Power Supply Trap Settings	95		
GPO Settings	96		
LED Settings	97		
Update	98		
<b>Technical Specifications RB-FS42</b>	<b>99</b>		
<b>6 RB-FS82 Audio Failover Switcher, 8 Main I/O, 2 Standby I/O</b>	<b>101</b>		
<b>Introduction</b>	<b>101</b>		
<b>Connections &amp; Operation</b>	<b>104</b>		
Front Panel	104		
<b>Rear Panel Connections</b>	<b>106</b>		
25 Way D-Type Connection Details	107		
<b>Typical Application</b>	<b>109</b>		
GPI Operation	110		

# Figures

Fig A:	RB-RK1Small Redbox Front Rack-mount Kit .	v	Fig 3-10:	Indication Page	47
Fig B:	RB-RK2 Small Redbox Rear Rack-mount Kit.	vi	Fig 3-11:	Unit Setup Page	48
Fig C:	RB-RK3 Large Redbox Rear Rack-mount Kit.	vi	Fig 3-12:	Miscellaneous Page	49
Fig 1-1:	RB-SD1 Front Panel	1	Fig 4-1:	RB-DSD8 Front Panel	53
Fig 1-2:	RB-SD1 System Block Diagram	2	Fig 4-2:	RB-DSD8 Status Buttons	55
Fig 1-3:	RB-SD1 Rear Panel	3	Fig 4-3:	RB-DSD8 Controls & Indicators For Each Channel	55
Fig 1-4:	RB-SD1 Front Panel	5	Fig 4-4:	RB-DSD8 Additional Indicators	57
Fig 2-1:	RB-SD1IP Front Panel	10	Fig 4-5:	RB-DSD8 Rear Panel DIPSwitches	58
Fig 2-2:	RB-SD1IP System Block Diagram	12	Fig 4-6:	RB-DSD8 Rear Panel	61
Fig 2-3:	RB-SD1IP Rear Panel	13	Fig 4-7:	Audio & GPI/O Connector Detail	61
Fig 2-4:	RB-SD1IP Front Panel	16	Fig 4-8:	Audio Connector Pin Numbers	62
Fig 2-5:	Sonifex Service Discovery - Bonjour Page	20	Fig 4-9:	GPI/O Remotes Connector Pin Numbers	62
Fig 2-6:	Sonifex Service Discovery - Legacy Discovery Page	20	Fig 4-10:	Communications Connectors	64
Fig 2-7:	RB-SD1IP Screenshot of the Webserver Home Page	21	Fig 4-11:	Status Page	69
Fig 2-8:	RB-SD1IP Screenshot of the Webserver Device Page	22	Fig 4-12:	Channel Status Page	70
Fig 2-9:	RB-SD1IP Screenshot of the Webserver Network Settings Page	23	Fig 4-13:	Miscellaneous Page	71
Fig 2-10:	RB-SD1IP Screenshot of the Webserver Level & Time Settings Page	24	Fig 4-14:	General Settings Page	72
Fig 2-11:	RB-SD1IP Screenshot of the Webserver Sources Page	25	Fig 5-1:	The RB-FS42 Front Panel	77
Fig 2-12:	RB-SD1IP Screenshot of the Webserver Alarms Page	26	Fig 5-2:	The RB-FS42 Diagram	79
Fig 2-13:	RB-SD1IP Screenshot of the Webserver SNMP Page	27	Fig 5-3:	The RB-FS42 Front Panel	80
Fig 2-14:	RB-SD1IP Screenshot of the Webserver USB Page	28	Fig 5-4:	The RB-FS42 Rear Panel	82
Fig 2-15:	RB-SD1IP Screenshot of the Webserver Remotes Page	29	Fig 5-5:	The RB-FS42 Female and Male Connectors	83
Fig 2-16:	RB-SD1IP Screenshot of the Webserver GPIO Page	30	Fig 5-6:	The RB-FS42 Bonjour Panel	89
Fig 2-17:	RB-SD1IP Screenshot of the Webserver Physical Settings Page	31	Fig 5-7:	The RB-FS42 Legacy Discovery Panel	89
Fig 2-18:	RB-SD1IP Screenshot of the Webserver Update Firmware Page	32	Fig 5-8:	The RB-FS42 Device Info Panel	90
Fig 3-1:	RB-DSD1 Front Panel	34	Fig 5-9:	The RB-FS42 Home Screen	91
Fig 3-2:	RB-DSD1 System Block Diagram	36	Fig 5-10:	The RB-FS42 Network Settings Screen	92
Fig 3-3:	RB-DSD1 Front Panel Controls and Indicators	36	Fig 5-11:	The RB-FS42 SNMP Screen	93
Fig 3-4:	SILENCE Detect Duration DIPSwitch	37	Fig 5-12:	The RB-FS42 Channel Settings Screen	94
Fig 3-5:	SILENCE Detect Audio Trigger Level DIPSwitch	38	Fig 5-13:	The RB-FS42 Power Supply Trap Settings Screen	95
Fig 3-6:	SILENCE Detect Stereo/Mono & Sync Source DIPSwitch	38	Fig 5-14:	The RB-FS42 GPO Settings Screen	96
Fig 3-7:	Rear Panel DIPSwitches	38	Fig 5-15:	The RB-FS42 LED Settings Screen	97
Fig 3-8:	RB-DSD1 Rear Panel	42	Fig 5-16:	The RB-FS42 Update Screen	98
Fig 3-9:	Serial Port Default Settings	43	Fig 6-1:	The RB-FS82 Front Panel	101
			Fig 6-2:	The RB-FS82 Diagram	103
			Fig 6-3:	The RB-FS82 Front Panel	104
			Fig 6-4:	The RB-FS82 Rear Panel	106
			Fig 6-5:	The RB-FS82 Female and Male Connectors	107

Fig 6-6: The RB-FS82 Bonjour Panel	113
Fig 6-7: The RB-FS82 Legacy Discovery Panel	113
Fig 6-8: The RB-FS82 Device Info Panel	114
Fig 6-9: The RB-FS82 Home Screen	115
Fig 6-10: The RB-FS82 Network Settings Screen	116
Fig 6-11: The RB-FS82 SNMP Screen	117
Fig 6-12: The RB-FS82 Channel Settings Screen	118
Fig 6-13: The RB-FS82 Power Supply Trap Settings Screen	119
Fig 6-14: The RB-FS82 GPO Settings Screen	120
Fig 6-15: The RB-FS82 LED Settings Screen	121
Fig 6-16: The RB-FS82 Update Screen	122

# SONIFEX

## Register Online for an Extended 2 Year Warranty

As standard, Sonifex products are supplied with a 1 year back to base warranty.

If you register the product online, you can increase your product warranty to 2 years and we can also keep you informed of any product design improvements or modifications.

Product: \_\_\_\_\_

Serial No: \_\_\_\_\_

To register your product, please go online to [www.sonifex.co.uk/register](http://www.sonifex.co.uk/register)

## Product Warranty - 2 Year Extended

As standard, Sonifex products are supplied with a 1 year back to base warranty. In order to register the date of purchase and so that we can keep you informed of any product design improvements or modifications, it is important to complete the warranty registration online. Additionally, if you register the product on the Sonifex website, you can increase your product warranty to 2 years. Go to the Sonifex website at: <http://www.sonifex.co.uk/technical/register/index.asp> to apply for your 2 year warranty.

**Note:** For your own records the product serial number is recorded on the CE certification page of this handbook.

## Sonifex Warranty & Liability Terms & Conditions

### 1. Definitions

‘the Company’ means Sonifex Ltd and where relevant includes companies within the same group of companies as Sonifex Limited.

‘the Goods’ means the goods or any part thereof supplied by the Company and where relevant includes: work carried out by the Company on items supplied by the Purchaser; services supplied by the Company; and software supplied by the Company.

‘the Purchaser’ means the person or organisation who buys or has agreed to buy the Goods.

‘the Price’ means the Price of the Goods and any other charges incurred by the Company in the supply of the Goods.

‘the Warranty Term’ is the length of the product warranty which is usually 12 months from the date of despatch; except when the product has been registered at the Sonifex website when the Warranty Term is 24 months from the date of despatch.

‘the Contract’ means the quotation, these Conditions of Sale and any other document incorporated in a contract between the Company and the Purchaser.

This is the entire Contract between the parties relating to the subject matter hereof and may not be changed or terminated except in writing in accordance with the provisions of this Contract. A reference to the consent, acknowledgement, authority or agreement of the Company means in writing and only by a director of the Company.

### 2. Warranty

- a. The Company agrees to repair or (at its discretion) replace Goods which are found to be defective (fair wear and tear excepted) and which are returned to the Company within the Warranty Term provided that each of the following are satisfied:
  - i. notification of any defect is given to the Company immediately upon its becoming apparent to the Purchaser;
  - ii. the Goods have only been operated under normal operating conditions and have only been subject to normal use (and in particular the Goods must have been correctly connected and must not have been subject to high voltage or to ionising radiation and must not have been used contrary to the Company’s technical recommendations);
  - iii. the Goods are returned to the Company’s premises at the Purchaser’s expense;
  - iv. any Goods or parts of Goods replaced shall become the property of the Company;
  - v. no work whatsoever (other than normal and proper maintenance) has been carried out to the Goods or any part of the Goods without the Company’s prior written consent;

- vi. the defect has not arisen from a design made, furnished or specified by the Purchaser;
  - vii. the Goods have been assembled or incorporated into other goods only in accordance with any instructions issued by the Company;
  - viii. the defect has not arisen from a design modified by the Purchaser;
  - ix. the defect has not arisen from an item manufactured by a person other than the Company. In respect of any item manufactured by a person other than the Company, the Purchaser shall only be entitled to the benefit of any warranty or guarantee provided by such manufacturer to the Company.
- b. In respect of computer software supplied by the Company the Company does not warrant that the use of the software will be uninterrupted or error free.
- c. The Company accepts liability:
- (i) for death or personal injury to the extent that it results from the negligence of the Company, its employees (whilst in the course of their employment) or its agents (in the course of the agency);
  - (ii) for any breach by the Company of any statutory undertaking as to title, quiet possession and freedom from encumbrance.
- d. Subject to conditions (a) and (c) from the time of despatch of the Goods from the Company's premises the Purchaser shall be responsible for any defect in the Goods or loss, damage, nuisance or interference whatsoever consequential economic or otherwise or wastage of material resulting from or caused by or to the Goods. In particular the Company shall not be liable for any loss of profits or other economic losses. The Company accordingly excludes all liability for the same.
- e. At the request and expense of the Purchaser the Company will test the Goods to ascertain performance levels and provide a report of the results of that test. The report will be accurate at the time of the test, to the best of the belief and knowledge of the Company, and the Company accepts no liability in respect of its accuracy beyond that set out in Condition (a).
- f. Subject to Condition (e) no representation, condition, warranty or other term, express or implied (by statute or otherwise) is given by the Company that the Goods are of any particular quality or standard or will enable the Purchaser to attain any particular performance or result, or will be suitable for any particular purpose or use under specific conditions or will provide any particular capacity, notwithstanding that the requirement for such performance, result or capacity or that such particular purpose or conditions may have been known (or ought to have been known) to the Company, its employees or agents.
- g. (i) To the extent that the Company is held legally liable to the Purchaser for any single breach of contract, tort, representation or other act or default, the Company's liability for the same shall not exceed the price of the Goods.
- (ii) The restriction of liability in Condition (g)(i) shall not apply to any liability accepted by the Seller in Condition (c).
- h. Where the Goods are sold under a consumer transaction (as defined by the Consumer Transactions (Restrictions on Statements) Order 1976) the statutory rights of the Purchaser are not affected by these Conditions of Sale.

## Unpacking Your Product

Each product is shipped in protective packaging and should be inspected for damage before use. If there is any transit damage take pictures of the product packaging and notify the carrier immediately with all the relevant

details of the shipment. Packing materials should be kept for inspection and also for if the product needs to be returned.

The product is shipped with the following equipment so please check to ensure that you have all of the items below. If anything is missing, please contact the supplier of your equipment immediately.

Item	Quantity
Product unit	1
IEC mains lead fitted with moulded mains plug	1
Handbook and warranty card	1

If you require a different power lead, please let us know when ordering the product.

## Repairs & Returns

Please contact Sonifex or your supplier if you have any problems with your Sonifex product. Email [technical.support@sonifex.co.uk](mailto:technical.support@sonifex.co.uk) for the repair/upgrade/returns procedure, or for support & questions regarding the product operation.

## CE Conformity

The products in this manual comply with the essential requirements of the relevant European health, safety and environmental protection legislation.

The technical justification file for this product is available at Sonifex Ltd.

The declaration of conformity can be found at:  
<http://www.sonifex.co.uk/declarations>

## Safety & Installation of Mains Operated Equipment

There are no user serviceable parts inside the equipment. If you should ever need to look inside the unit, always disconnect the mains supply before removing the equipment covers. The cover is connected to earth by means of the fixing screws. It is essential to maintain this earth/ground connection to ensure a safe operating environment and provide electromagnetic shielding.

### Voltage Setting Checks

Ensure that the machine operating voltage is correct for your mains power supply by checking the box in which your product was supplied. The voltage is shown on the box label. The available voltage settings are 115V, or 230V. Please note that all products are either switchable between 115V and 230V, or have a universal power supply.

### Fuse Rating





The product is supplied with a single fuse in the live conducting path of the mains power input. For reasons of safety it is important that the correct rating and type of fuse is used. Incorrectly rated fuses could present a possible fire hazard, under equipment fault conditions. The active fuse is fitted on the outside rear panel of the unit.

### Power Cable & Connection

An IEC power connector is supplied with the product which has a moulded plug attached.

The mains plug or IEC power connector is used as the disconnect device. The mains plug and IEC power connector shall remain readily operable to disconnect the apparatus in case of a fault or emergency.

The mains lead is automatically configured for the country that the product is being sent to, from one of:

Territory	Voltage	IEC Lead Type	Image
UK & Middle East	230V	UK 3 pin to IEC lead	
Europe	230V	European Schuko round 2 pin to IEC lead	
USA, Canada and South America	115V	3 flat pin to IEC lead	
Australia & New Zealand	230V	Australasian 3 flat pin to IEC lead	

Connect the equipment in accordance with the connection details and before applying power to the unit, check that the machine has the correct operating voltage for your mains power supply.

This apparatus is of a class I construction. It must be connected to a mains socket outlet with a protective earthing connection.

**Important note:** If there is an earth/ground terminal on the rear panel of the product then it must be connected to Earth.

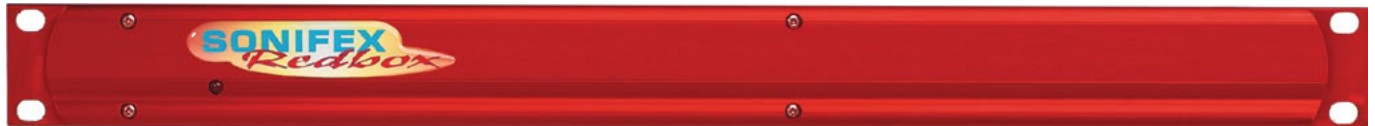

Fig A: RB-RK1Small Redbox Front Rack-mount Kit .

## WEEE Directive



The Waste Electrical and Electronic Equipment (WEEE) Directive was agreed on 13 February 2003, along with the related Directive 2002/95/EC on Restrictions of the use of certain Hazardous Substances in electrical and electronic equipment (RoHS). The Waste Electrical and Electronic Equipment Directive (WEEE) aims to minimise the impacts of electrical and electronic equipment on the environment during their life times and when they become waste. All products manufactured by Sonifex Ltd have the WEEE directive label placed on the case. Sonifex Ltd will be happy to give you information about local organisations that can reprocess the product when it reaches its “end of use”, or alternatively all products that have reached “end of use” can be returned to Sonifex and will be reprocessed correctly free of charge.

## Atmosphere/Environment

This apparatus should be installed in an area that is not subject to excessive temperature variation (<0°C, >50°C), moisture, dust or vibration.

This apparatus shall not be exposed to dripping or splashing, and no objects filled with water, such as vases shall be placed on the apparatus.

## Fitting Redboxes

Redboxes can be fixed to the underside of a desk, or other surfaces using 4.2mm holes in the sides and fixed with 2 x M4 screws or 2 x No. 6 countersink wood screws.

They can also be rack-mounted, with either the front, or rear of the Redbox positioned at the front of the rack (Note: this product is front rack-mounted as standard):

**Front Mounting Redboxes:** For rack mounting smaller (28cm) units the optional **RB-RK1** (Red) or **RB-RK1B** (Black) kit can be used (which include 4 off M6 panel fixing screws).

**Rear Mounting a Redbox:** For rear panel mounting you can use either the **RB-RK2** (in this case), or **RB-RK3**, depending on the size of your Redbox.

**RK2**

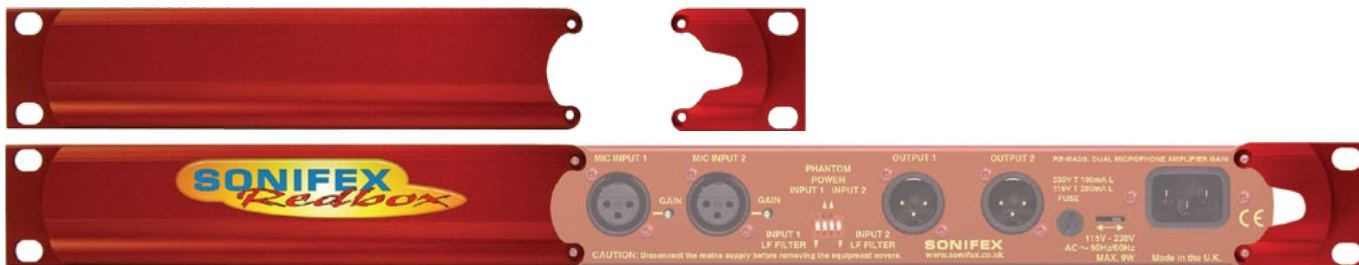

Fig B: RB-RK2 Small Redbox Rear Rack-mount Kit.

**RK3**



Fig C: RB-RK3 Large Redbox Rear Rack-mount Kit.

# 1 RB-SD1 Silence Detection Unit

## Introduction



Fig 1-1: RB-SD1 Front Panel

The RB-SD1 Silence Detect Unit is a 1U rack mount device used to monitor an unattended stereo studio feed and in the event of the signal going “quiet” after a given period the unit will switch through an alternative stereo audio signal. This signal could be a recorded message (e.g. “normal service will be resumed”, etc), a feed from a CD player or minidisk machine, or an alternative recorded program. Controls are provided to start external equipment and to provide remote status indication.

It has 2 balanced stereo audio inputs with the maximum input level being +28dBu. Each input is user-defined as either the main source or auxiliary source and both sources are monitored for failure, each having a remote failure alarm. In the event of the main source dropping below a pre-set level for a pre-determined amount of time, the unit will automatically switch through to the auxiliary signal. The silence detect level is adjustable between -60dBu and -15dBu in 3dB steps via a 16 position rotary switch on the rear panel. The silence interval can be adjusted between 2 seconds to 30 seconds in 2 second steps, or, alternatively, set to 2 minutes 5 seconds also via a 16 position rotary switch on the rear panel. The audio outputs use stereo professional balanced XLR-3 male connectors.

The unit can operate in 2 modes - automatic or manual. In both modes it will automatically switch over to the auxiliary source on detecting silence. When the main signal is again detected it will either return to the main signal automatically or manually depending on the mode chosen.

The RB-SD1 has a number of remote operational features. Remote outputs provide separate relay contact closures for failure of the main and auxiliary inputs. You can also control remotely all of the front panel switches for source selection, mode selection and signal Restore. You can remotely start and stop another piece of equipment on alarm failure and main signal return respectively. Also, the longest silence time (2min 5sec) can be set remotely, which is useful if you are expecting to broadcast a long silence.

The unit can be configured to alarm when either the left or right channel of the main input source fails, or if the whole stereo signal fails. There are also options to set the remote start output as momentary or latched, to disable switching to the auxiliary input on alarming and to increase the gain on the auxiliary input so that an unbalanced input can be used, for example, from a domestic minidisc player.

Front panel LED indicators show individually left and right programme and alarm conditions for both the main and auxiliary inputs. The status of the source, mode and alarm state are also shown on the front panel with LED indicators.

Additionally, the RB-SD1 can be programmed for specific applications, which can be defined on power-up of the unit, e.g. for extended silence detect times. See page 7 for current additional power-up modes, or contact Sonifex for further information if you have a particular requirement.

The RB-SD1 has been designed to have a passive signal path through the main input, so if power to the unit fails, the signal input will still be routed through to the output. This is essential for applications such as installation at transmitter sites, where a power failure to the unit should not prevent the audio input signal from being output to the transmitter.

## System Block Diagram

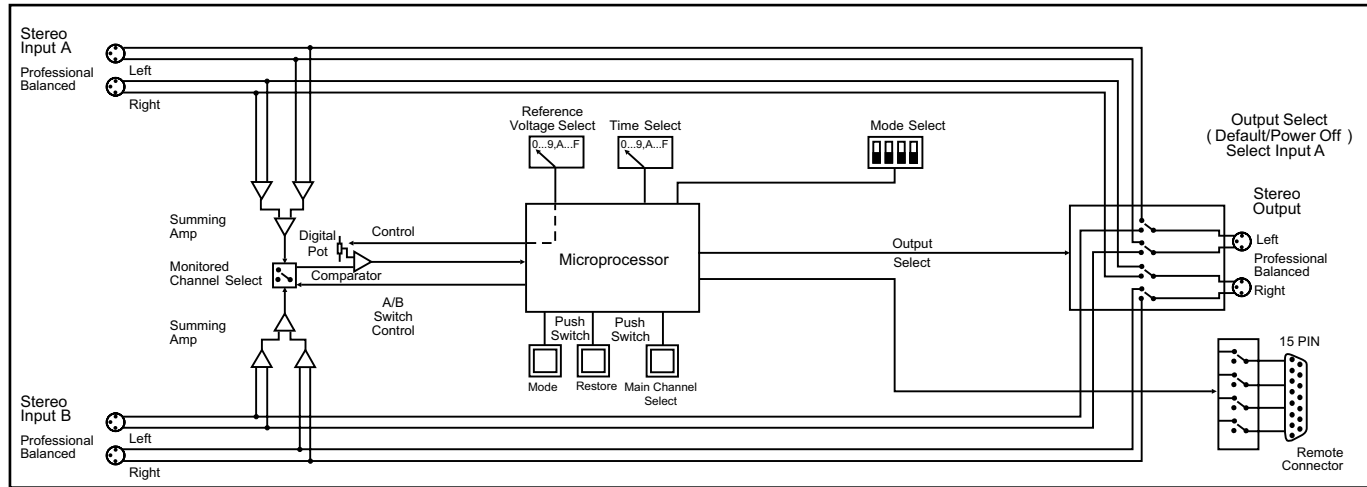

Fig 1-2: RB-SD1 System Block Diagram

## Rear Panel Connections and Operation

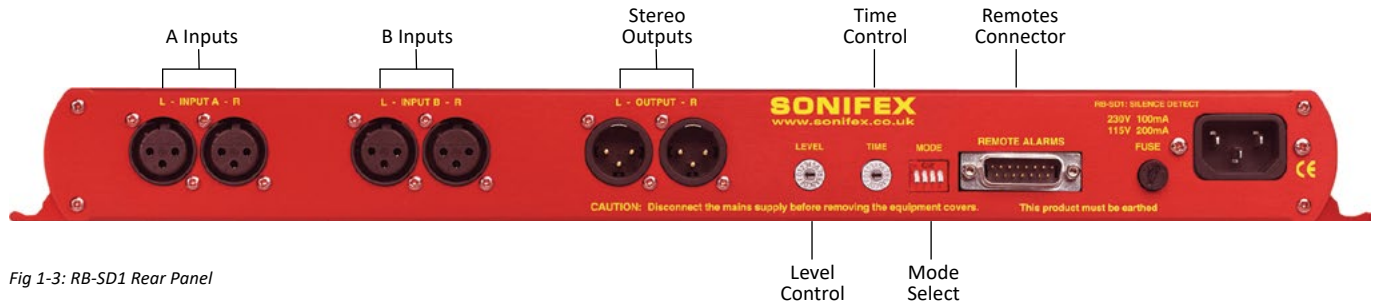

Fig 1-3: RB-SD1 Rear Panel

### A/B Inputs (Left and Right)

There are four XLR-3 inputs, two for channel A (Left & Right) and another two for channel B (Left & Right). The XLR 3 pin sockets are used for the input channels and are electronically balanced. They have the following connections: -

- Pin 1: Screen.
- Pin 2: Phase.
- Pin 3: Non-phase.

### Outputs

The stereo input consists of two XLR male connectors professionally balanced with following connections: -

- Pin 1: Screen.
- Pin 2: Phase.
- Pin 3: Non-phase.

### Silence Detect Trigger Level

The trigger level rotary switch (Level) adjusts the level below which silence detection occurs. This level may be varied from -15dB to -60db in 3db steps by adjusting the switch, which is accessible on the rear panel.

Switch	0	1	2	3	4	5	6	7	8	9	A	B	C	D	E	F
Level dBu	-60	-57	-54	-51	-48	-45	-42	-39	-36	-33	-30	-27	-24	-21	-18	-15

### Silence Detect Interval Control

The silence detect interval rotary switch (Time) adjusts the duration over which a silence is detected before alarming and ranges from 2-30 seconds (0 – E in 2 second intervals) with F on the switch being a 2 min 5 second silence. This maximum time can also be activated or de-activated remotely via the remote connector.

Switch	0	1	2	3	4	5	6	7	8	9	A	B	C	D	E	F
Seconds	2	4	6	8	10	12	14	16	18	20	22	24	26	28	30	125

### Mode Dip Switch Settings

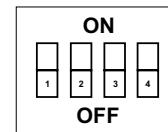

1. Stereo/Mono.
2. Remote Start Mode Switch.
3. Professional levels/Consumer levels (Input B).
4. Switch/No switching when alarmed.

**1. Stereo/Mono Switch** – The configuration of this defines whether you want to switch sources when left and/or right channel of the incoming source go silent.

Switch	Description
On	When on, the unit operates in stereo mode, whereby if one channel goes quiet the unit will switch, and requires both channels to be present before it switches back.
Off	When off, the unit operates in mono mode. In this mode the unit will only switch when both channels go quiet, and requires only one channel to be present before the unit switches back.

**2. Remote Start Mode Switch** – This defines whether the remote start switch is momentary or latched. Used for starting external equipment when silence is detected.

Switch	Description
On	When on, the remote start pin (pin 15) on the remote connector is pulled low for half a second when the unit switches to the auxiliary input. (Momentary contact).
Off	When off, the remote start pin on the remote connector is pulled low when the unit switches over to the auxiliary input and remains low until the unit switches back to the main source or, if in manual mode, is restored by the user locally or remotely. (Latched contact).

**3. Professional/Consumer Switch** – This allows you to use an unbalanced piece of equipment as the auxiliary input, by raising the input gain.

Switch	Description
On	When on, Input B accepts professional balanced signal level.
Off	When off, Input B accepts consumer unbalanced signal level and raises the input gain received by 12dB.

**4. Switch/No Switching in alarm state** – This defines whether the unit switches to the auxiliary input on silence detection.

Switch	Description
On	When on, if the unit goes into the alarm state the unit switches to the auxiliary input.
Off	When off, if the unit goes into the alarm state the unit does not switch to the auxiliary input.

**Remotes Connector**

Displayed below are the pin connections and descriptions for the remote connector:

Pin No.	Signal	I/O	Description
Pin 1	Master Alarm Normally Open	O	Relay 1 N/O to Pin 9 in alarm state
Pin 2	Master Alarm Normally Closed	O	Relay 1 N/C to Pin 9 in alarm state
Pin 3	Aux. Alarm Normally Open	O	Relay 2 N/O to Pin 11 in alarm state
Pin 4	Aux. Alarm Normally Closed	O	Relay 2 N/C to Pin 11 in alarm state
Pin 5	Mode Switch	I	Momentary make to Pin 8
Pin 6	Mode Indicator	O	Internal Open Collector to Digital Ground
Pin 7	Restore Switch	I	Momentary make to Pin 8

Pin 8	Digital Ground	-	-
Pin 9	Master Alarm Common	O	N/O to Pin 1, N/C to Pin 2 in alarm state
Pin 10	Max Time Whilst Latched	I	Latched make to Pin 8
Pin 11	Aux. Alarm Common	O	N/O to Pin 3, N/C to Pin 4 in alarm state
Pin 12	+5V	O	To power up to a maximum 100mA
Pin 13	Source Select Indicator	O	Internal Open Collector to Digital Ground
Pin 14	Source Select Switch	I	Momentary make to Pin 8
Pin 15	Remote Start	O	Internal Open Collector to Digital Ground

Pins 1 - 4 are for external use to replicate the alarm conditions for the Main and Auxiliary inputs.

Pins 5 - 7, 13 and 14 are to replicate the switches and indicators for the source select, mode and restore functions.

Pins 8, 9, 11 and 12 are common or voltage pins.

Pin 10 is to select remotely the maximum silence time (2min 5sec). This may be useful for the broadcast of Remembrance Day services, or where you expect a silence of up to 2 minutes to be broadcast. The maximum silence time is set whilst the contact is latched.

Pin 15 is used to remotely start an external piece of equipment and operates on audio fail.

### Front Panel Selectors and Indicators



Fig 1-4: RB-SD1 Front Panel

### Source Select and Indicator

The normal Main input source is selectable via a push switch accessed via a hole located on the front panel, or it can be controlled remotely (pins 13 and 14). This allows you to define whether input A, or input B is going to be your Main audio input. There is an LED to indicate which state the source select is set:

LED	Description
LED On	Main source is input A, Aux source is input B
LED Off	Main source is input B, Aux source is input A

**Note : If the unit is powered off, for example during a black-out, input A routes through to the output. Therefore if the unit is subject to a power fail while the main source is set to input B, the unit will output source A.**

### Mode Selector and Indicator

The Mode Switch defines how the unit should operate during an alarm condition, when the main audio source returns. There is an option to allow the device to switch back Automatically or Manually. The mode is selected by a push switch accessed through a hole on the front panel with a corresponding LED to represent its state, or it can be controlled remotely (pins 5 and 6).

LED	Description
LED On	Automatic Mode – During an alarm condition when the main source returns, it is switched back automatically, although there must be a continuous signal present for two seconds before it switches.
LED Off	Manual Mode – When the alarm condition is reached, the LED begins to flash.
LED Flashing	Manual Mode – The main audio has returned after an alarm condition. To switch to the main source, push the Restore button (or control it remotely).

### Main and Aux Indicators

On the front panel there are four Main indicators and four Aux indicators. Each left/right channel has a Program Content and Alarm Status indicator. The Program Content Indicator represents the input signal level for that channel and the Alarm Status LED indicates when the channel has dropped below the threshold for longer than the time selected.

Both the Main and Aux inputs are continuously monitored so that you can check that your backup signal is operating correctly, as well as your main input source.

**Note: Although one channel of the stereo input may have alarmed, the main alarm may not be set, due to the setting of the Stereo/Mono Dipswitch.**

### Alarm Indicator

The Alarm indicator situated on the front panel is used to display the alarm status of the Main input. Its operation is dependant on the selected mode. When in stereo mode the unit alarms on a single main channel timeout, and in mono, alarms on both main channels timing out. The unit exits the alarm state on the return of the main source signal, depending on the setting of the Stereo/Mono Dipswitch. The alarm indicator is remotely indicated on pins 1 and 2 of the remotes connector.

**Restore Button**

The restore button is used for restoring the main source signal when the unit is operating in Manual Mode. When the main source signal returns after it has timed out, the Mode LED flashes, indicating that the source signal can be restored. When the Restore button is pressed the main source returns. This can be remotely controlled using pin 7 of the remotes connector.

**Additional Modes**

An option to set the unit in different modes of operation is available and is selectable when the unit is powered on. The current available modes of operation are as follows:

**Normal Mode** is as described previously for normal machine power-up.

**Remote Stop Mode** operates as follows. When the main source returns from an alarmed state, pin 4 on the remote connector (Aux Alarm) closes to Pin 11 (Aux Alarm Common) for half a second. (Note: this will only occur when the Remote Start Mode Switch is set on (page 4) and whilst in Remote Stop Mode the Aux alarm is not available to indicate the presence of audio on the auxiliary input).

**Remote Alarm Set Mode** operates as follows. When the RESTORE pin on the remote connector (pin 7) closes to the DIGITAL GROUND pin on the remote connector (pin 8) the unit will immediately enter an alarmed state and switch to the auxiliary input. This alarm state is continued until the RESTORE pin opens to the DIGITAL GROUND pin. After this the unit will switch back to the main input when audio is present.

**NOTE: When operating in manual mode, restoration of output from the main input is only available via the front panel restore switch. All other functions operate as normal.**

**Signal Detection Mode** In this mode the three controls, source, remote source, mode, remote mode, restore and remote restore have no effect.

The count in time for the signal detection is zero, i.e. as soon as signal is detected on an input the relevant relay will switch. The relays operate the same as in normal mode, i.e. when audio is detected on the main input, pin 1 on the remote connector closes to pin 9. When audio is lost on the main input, pin 2 on the remote connector closes to pin 9. All other functions operate as with normal mode.

**Timeout x 2 Mode.** In this mode, the timeout selection is multiplied by two (see table on the following page), except for the max time selection (position F on the time rotary encoder). All other functions operate as normal.

Switch	0	1	2	3	4	5	6	7	8	9	A	B	C	D	E	F
Seconds	4	8	12	16	20	24	28	32	36	40	44	48	52	56	60	125

**Force Main Mode.** In this mode only the remote mode control input has any effect. When this control input is active (low) the output is forced to input B (the master input) regardless of whether audio is present. The unit operates in auto mode and with input B as the master input. All other functions operate as with normal mode.

**Emergency Program Override Mode.** In this mode all alarm LEDs are illuminated whenever the main input is active. This is to indicate that the emergency paging program is active on the main input. When the paging program goes silent, the unit will revert back to the aux. input and all the alarm LEDs will switch off. The front panel source button is disabled. All other functions operate as normal.

**Detection Enable/Disable Mode.** In this mode the silence detection can be disabled and enabled remotely. The front panel and remote source select controls are used to enable or disable the Silence Detection feature.

Front panel Source indicator on	=	Silence Detection enabled
Front panel Source indicator off	=	Silence Detection disabled

The front panel source select button toggles this state, while the remote Source control (Pin 14 on the remote connector) can only ENABLE Silence Detection. Pin 10 on the remote connector is used to DISABLE Silence Detection. When the unit powers up Silence Detection is always enabled. The remote source select indicator (Pin 13 on the remote connector) is enabled when Silence Detection is disabled. In this mode input A is always the Main input and input B is always the Aux input. Since the front panel and remote source selection controls are disabled, source selection is not allowed in this mode. The Aux alarms are masked for both front panel indicators and remote alarm relay, for as long as the main input is present.

**Return Time Set Mode.** In this mode, the unit operates as normal, except that during power up the return time delay can be programmed. The return time delay is the amount of time, during an alarm condition, that the unit takes to switch from the Aux to Main input once audio is presented to the Main input. To set the return time, immediately after the unit is switched on, press and hold the MODE switch. While the MODE switch is pressed set the TIME rotary switch to required setting (see below). When finished, release the MODE switch, and the unit will start operating within a few seconds. Remember to return the TIME rotary switch to the required setting.

Rotary Setting	0	1	2	3	4	5	6	7	8	9	A	B	C	D	E	F
Seconds	0	2	4	6	8	10	12	14	16	18	20	22	24	26	28	120

**To Set the Additional Modes:**

Apply power to the unit, and while the front panel ALARM LED is flashing, press and hold the RESTORE button. The MAIN and AUX PROG and ALARM LEDs will flash alternately - these are used to indicate the selected mode. The SOURCE LED will also alternate to show the mode bank that is currently selected.

**Note: For RB-SD1 units with serial number greater than RB031084, the SOURCE LED is used to show the bank of the selected mode. For serial**

**numbers before this, the SOURCE LED is not used. Contact Sonifex Ltd if you want to upgrade your RB-SD1 unit to the latest version to take advantage of a new mode.**

To select the particular mode, release the RESTORE button when the corresponding LED below is on. After the button is released the unit will start working after five seconds. You only have to do this once as the mode is stored in non-volatile memory and you will only need to repeat this procedure if you wish to select a different mode. Each time the unit is powered on, the selected mode is visible by checking which LED is on:

Bank 0 (SOURCE LED off)		Mode Selected
MAIN LEFT PROG LED on	=	Normal Mode
MAIN LEFT ALARM LED on	=	Remote Stop Mode
MAIN RIGHT PROG LED on	=	Remote Alarm Set Mode
MAIN RIGHT ALARM LED on	=	Signal Detection Mode
AUX. LEFT PROG LED on	=	Timeout Times 2 Mode
AUX. LEFT ALARM LED on	=	Force Main Mode
AUX. RIGHT PROG LED on	=	Emergency Program Override Mode
AUX. RIGHT ALARM LED on	=	Detection Enable/Disable Mode

Bank 1 (SOURCE LED on)		
MAIN LEFT PROG LED on	=	Return Time Set Mode
MAIN LEFT ALARM LED on	=	Reserved
MAIN RIGHT PROG LED on	=	Reserved
MAIN RIGHT ALARM LED on	=	Reserved
AUX. LEFT PROG LED on	=	Reserved
AUX. LEFT ALARM LED on	=	Reserved
AUX. RIGHT PROG LED on	=	Reserved
AUX. RIGHT ALARM LED on	=	Reserved

## Technical Specifications RB-SD1

### Audio Specifications

Maximum Input Level:	+28dBu
Input Impedance:	> 100kΩ balanced
Maximum Output Level:	+28dBu
Output Impedance:	As input, except when using unbalanced auxiliary input where output impedance < 50Ω
Frequency Response:	20Hz to 20kHz ±0.1dB
Gain:	+12dB (for unbalanced input B – optional)
Noise:	<-87dB, unity gain, ref +8dBu output for unbalanced input.
Distortion:	As input for balanced input, <0.05% ref +8dBu output for unbalanced input.

### Connections

Inputs (Main & Auxiliary):	4 x XLR 3 pin female (balanced, auxiliary can be unbalanced)
Output:	2 x XLR 3 pin male (balanced)
Remotes:	15 way D-type plug
Power:	Filtered IEC, 110-120V, or 220-240V switchable, fused, 6W maximum
Fuse Rating:	Anti-surge fuse 100mA 20 x 5mm (230VAC) Anti-surge fuse 250mA 20 x 5mm (115VAC)

### Rear Panel Controls

Alarm Threshold:	-15dBu to -60dBu in 3dB steps via rotary switch
Silence Detect Duration:	2 sec to 30 sec in 2 second intervals and 125 second option via rotary switch
Detection Type:	Mono or stereo, via dipswitch
Silence Switch Defeat:	Disable/enable silence switching, via dipswitch
Remote Start Mode:	Latched or momentary, via dipswitch

### Front Panel Controls and Indicators

Controls:	Source select, mode select and restore
Indicators:	Program and alarm indicators for left and right source for both main and auxiliary channels Source, mode and restore LEDs

### Equipment Type

RB-SD1:	Silence detection unit
---------	------------------------



### Physical Specifications

Dimensions (Raw):	48cm (W) x 10.8cm (D) x 4.2cm (H) (1U) 19" (W) x 4.3" (D) x 1.7" (H) (1U)
Dimensions (Boxed):	53cm (W) x 20.5cm (D) x 6cm (H) 21" (W) x 8" (D) x 2.4" (H)
Weight:	Nett: 1.4kg Gross: 2.0kg Nett: 3.1lbs Gross: 4.4lbs

## 2 RB-SD1IP Silence Detection Unit With Ethernet & USB

### Introduction



Fig 2-1: RB-SD1IP Front Panel

The RB-SD1IP Silence detection unit is an upgraded version of the existing Sonifex RB-SD1. The unit is a 1U rack mount device used to monitor an unattended stereo studio feed and in the event of the signal going “quiet” after a given period the unit will switch through an alternative stereo audio signal. This signal could be a recorded message (e.g. “Normal service will be resumed”, etc), a feed from a CD or minidisc player, or an alternative recorded program. Controls are provided to start external equipment and to provide remote status indication.

The RB-SD1IP has several new features in addition to the functionality of the standard RB-SD1.

Ethernet connectivity provides the ability to set up and control the unit via a browser based Graphical User Interface (GUI). The network capabilities allow the user to more finely control silence Levels (-60dBu to 0dBu in 3dB steps) and Time delays (1 second to 24 hours), you can also remotely lock/unlock the front panel controls on the unit and choose to use either the hardware configured settings or web based settings. In addition to the front panel LEDs the GUI home page also offers a real time view of signal levels and alarm statuses.

Also using the GUI, left and right channels can be treated independently, remote relay triggers can be configured as one of many events including the new GPI pins. You can also choose to lock/unlock the use of the remote pins to control the unit. Firmware updates can also be performed using the web GUI.

SNMP V1 is implemented so that the unit can be monitored by existing Network Management Systems (NMS). The addition of 6 extra GPI pins to the rear panel, allows customisable functionality, including the use of the RB-SD1IP network interface to generate SNMP Traps on behalf of other, non-networked, hardware.

The RB-SD1IP has been fitted with a USB interface on the front panel and can act as a host in two ways. Firstly the USB port can be used to upgrade the firmware on the unit from a USB flash drive. Such a drive can also hold a pre-recorded message which the unit can play out in the event that both main and auxiliary signals both fall silent.

As on the standard RB-SD1, the RB-SD1IP has 2 balanced stereo audio inputs with a maximum input level of +28dBu. Each input is user-defined as either the main source or auxiliary source and all channels are monitored for failure. In the event of the main source dropping below a pre-set level for a pre-determined amount of time, the unit will automatically attempt to switch through to a valid auxiliary signal. The silence detect level is adjustable between -60dBu and -15dBu in 3dB steps via a 16 position rotary switch on the rear panel. The silence interval can be adjusted between 2 seconds to 30 seconds in 2 second steps, or, alternatively, set to 2 minutes 5 seconds also via a 16 position rotary switch on the rear panel. More fine control of the detection levels and times can be set using the web browser based GUI. The audio inputs and outputs use stereo professional balanced XLR-3 connectors.

The unit has 2 operational modes for restoring a signal - automatic or manual. In both modes the unit will automatically switch over to a valid auxiliary source upon detecting silence. When a valid main signal returns it will either restore to the main channel automatically or manually depending on the mode selected.

The RB-SD1IP has a number of remote operational features. Rear panel remote outputs provide separate relay contact closures for failure of the main and auxiliary inputs. You can also remotely control all of the front panel switches for source selection, mode selection and signal Restore. You can remotely start and stop another piece of equipment on alarm failure and main signal return respectively. A silence time of 2 minutes and 5 seconds can be set remotely, which is useful if you are expecting to broadcast a long silence.

The unit has three signal type operational modes – Stereo, Mono and Independent. In stereo mode, the unit will alarm if either the left or right channel falls silent. In mono mode the unit will only alarm if both left and right channels fall silent. In independent mode the unit can be configured to operate as a 2 channel mono silence detector, alarming and switching the two input channels independently. There are also options to set the remote start output as momentary or latched, to disable switching to the auxiliary input on alarming and to increase the gain on the auxiliary inputs so that unbalanced sources can be used, for example, from a domestic flash memory/USB player.

Front panel LED indicators show individually left and right programme status and alarm conditions for both the main and auxiliary inputs. The status of the source, mode and alarm state are also shown on the front panel with LED indicators.

The RB-SD1IP has been designed to have a passive signal path through the main input, so if power to the unit fails, the signal input will still be routed through to the output. This is essential for applications such as installation at transmitter sites, where a power failure to the unit should not prevent the audio input signal from being output to the transmitter.

### System Block Diagram

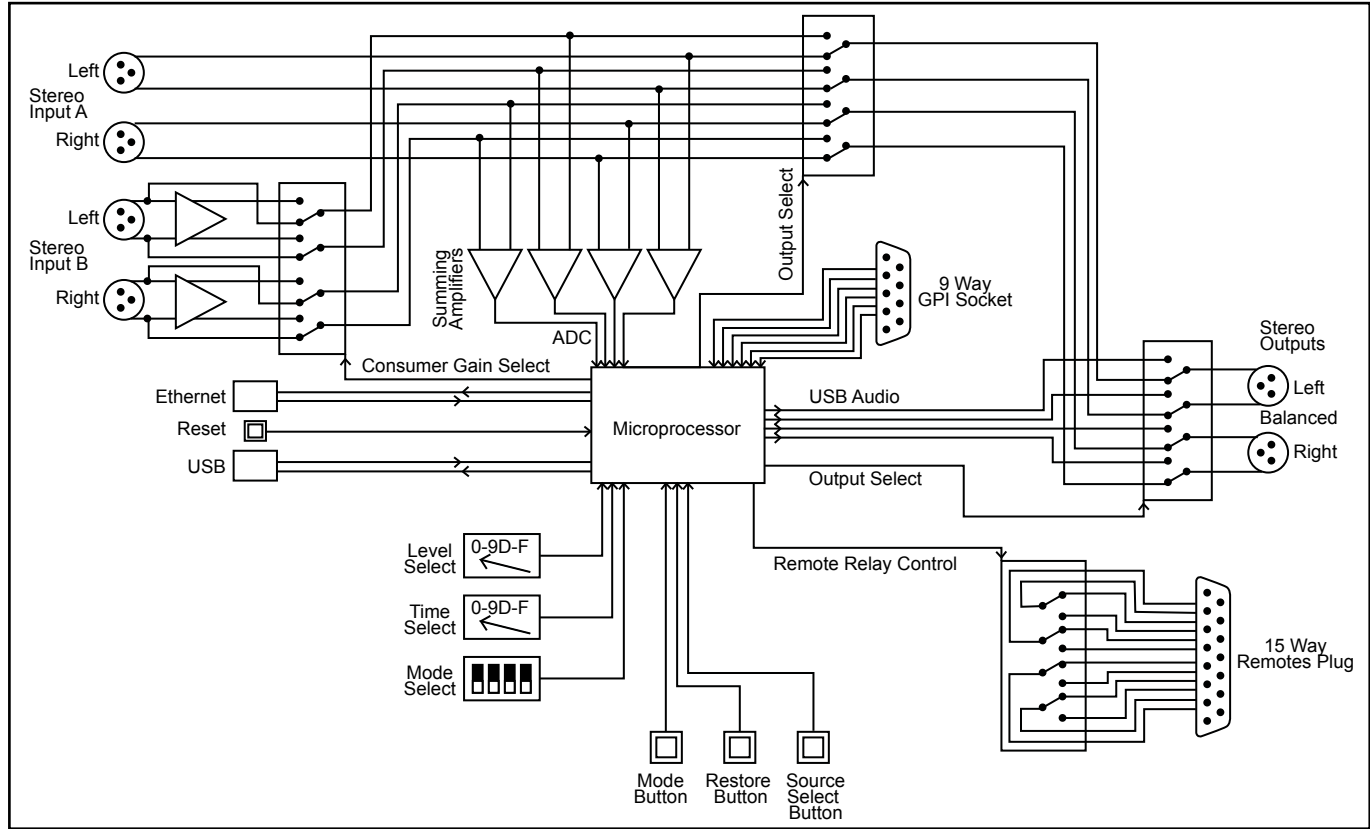

Fig 2-2: RB-SD1IP System Block Diagram

## Rear Panel Connections and Operation

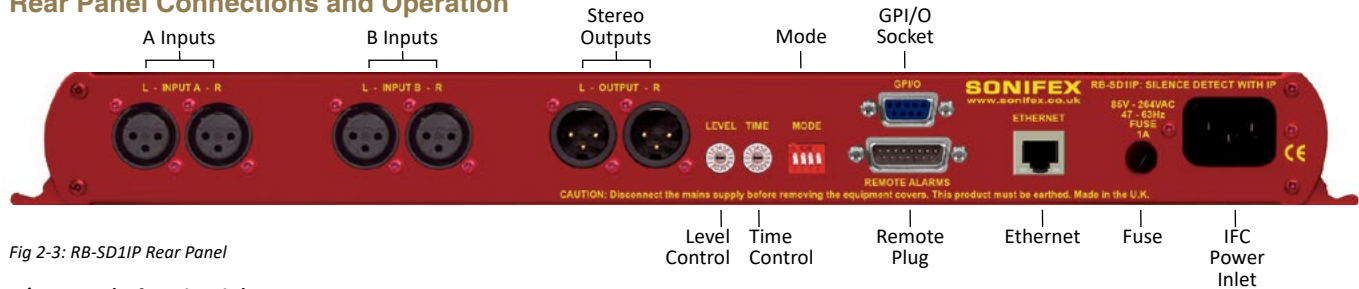

Fig 2-3: RB-SD1IP Rear Panel

### A/B Inputs (Left and Right)

There are four XLR-3 inputs, two for channel A (Left & Right) and another two for channel B (Left & Right). The XLR 3 pin sockets are used for the input channels and are electronically balanced. They have the following connections: -

- Pin 1: Screen.
- Pin 2: Phase.
- Pin 3: Non-phase.

### Outputs

The stereo output consists of two XLR male connectors professionally balanced with following connections: -

- Pin 1: Screen.
- Pin 2: Phase.
- Pin 3: Non-phase.

### Silence Detect Trigger Level

The Level rotary switch adjusts the level below which silence detection occurs. This level may be varied from -15dB to -60db in 3db steps by adjusting the switch according to the following table:

Switch	0	1	2	3	4	5	6	7	8	9	A	B	C	D	E	F
Level dBu	-60	-57	-54	-51	-48	-45	-42	-39	-36	-33	-30	-27	-24	-21	-18	-15

### Silence Detect Interval Control

The silence detect interval rotary switch (Time) adjusts the duration over which a silence must persist before alarming the unit. The time ranges from 2 to 30 seconds (0 – E in 2 second intervals) with F on the switch being a 2 min 5 second silence. This maximum time can also be activated or de-activated remotely using the remote connector.

Switch	0	1	2	3	4	5	6	7	8	9	A	B	C	D	E	F
Seconds	2	4	6	8	10	12	14	16	18	20	22	24	26	28	30	125

Note: Better control of the Silence Detect Level and Interval are available by using the Webserver built into the RB-SD1IP. See section 4 for more information.

### Mode DIP Switch Settings

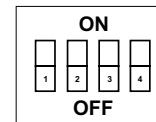

1. Stereo/Mono.
2. Remote Start Mode Switch.
3. Professional levels/Consumer levels (Input B).
4. Switch/No switching when alarmed.

**1. Stereo/Mono Switch** – The configuration of this defines whether you want to switch sources when left and/or right channel of the incoming source go silent.

Switch	Description
On	When on, the unit operates in stereo mode, whereby if one channel falls silent the unit will switch, and requires both channels to be present before it switches back.
Off	When off, the unit operates in mono mode. In this mode the unit will only switch when both channels go quiet, and requires only one channel to be present before the unit switches back.

**Note:** the Independent channel option can only be configured using the web based GUI not by using physical rear panel controls.

**2. Remote Start Mode Switch** – This defines whether the remote start switch is momentary or latched. Used for starting external equipment when silence is detected.

Switch	Description
On	When on, the remote start pin (pin 15) on the remote connector is pulled low for half a second when the unit switches to the auxiliary input. (Momentary contact).
Off	When off, the remote start pin on the remote connector is pulled low when the unit switches over to the auxiliary input and remains low until the unit switches back to the main source or, if in manual mode, is restored by the user locally or remotely. (Latched contact).

**3. Professional/Consumer Switch** – This allows you to use an unbalanced piece of equipment as the auxiliary input, by raising the input gain.

Switch	Description
On	When on, Input B accepts professional balanced signal level.
Off	When off, Input B accepts consumer unbalanced signal level and raises the input gain received by 8dB.

**4. Switch/No Switching in Alarm State** – This defines whether the unit switches to the auxiliary input upon silence detection.

Switch	Description
On	When on, if the unit goes into the alarm state the unit switches to the auxiliary input.
Off	When off, if the unit goes into the alarm state the unit does not switch to the auxiliary input.

#### Remote Alarms Connector

Displayed below are the pin connections and descriptions for the remote plug connector:

Pin No.	Signal	I/O	Description
Pin 1	Digital Ground	-	-
Pin 2	Restore Switch	I	Momentary make to Pin 1
Pin 3	Mode Indicator	O	Internal Open Collector to Digital Ground
Pin 4	Mode Switch	I	Momentary make to Pin 1
Pin 5	Relay 2 Normally Closed	I/O	Relay 2 N/C to Pin 14
Pin 6	Relay 2 Normally Open	I/O	Relay 2 N/O to Pin 14 Ground
Pin 7	Relay 1 Normally Closed	I/O	Relay 1 N/C to Pin 15
Pin 8	Relay 1 Normally Open	I/O	Relay 1 N/O to Pin 15
Pin 9	Remote Start	O	Internal Open Collector to Digital Ground
Pin 10	Source Select Switch	I	Momentary make to Pin 1
Pin 11	Source Select Indicator	O	Internal Open Collector to Digital Ground
Pin 12	+5V	O	To power up to a maximum 200mA

Pin 13	Relay 2 Common	I/O	N/O to Pin 6, N/C to Pin 5
Pin 14	Max Time Whilst Latched	I	Active Low make to Pin 1
Pin 15	Relay 1 Common	I/O	N/O to Pin 8, N/C to Pin 7

**Please note:** Pins 5, 6, 7, 8, 13 and 15 are for external use to break/make contacts in response to a configurable event in the unit. For example these relays can be used to replicate the alarm conditions for the Main and Auxiliary inputs. Options for these relays may be configured using the web based GUI. The operation of Relay 1 and Relay 2 can be re-configured through the Configuration>Remotes web page.

By default Relay 1 is set as the Main alarm and will alarm on either Main left or Main right - in the alarm state pin 8 closes to pin 15 and pin 7 is open. Relay 2 is set as the Aux alarm and alarms on Aux left or Aux right - under the alarm condition pin 6 closes to pin 14 and pin 5 is open.

Pins 2, 3, 4, 10 and 11 are to replicate the switches and indicators for the Source Select, Mode and Restore functions.

Pin 11 can be configured through the web GUI to indicate either the main source selection or the current output signal source.

**Note:** The remote source select, pin 10, may be held low in order to force the unit to route stereo input source B to the outputs.

Pins 1 & 12 are Ground and +5V respectively and can be used to source up to 200mA of current to power external circuitry such as LED indicators or relays.

Pin 14 is to select remotely a silence time of 2 minutes and 5 seconds. This may be useful for the broadcast of Remembrance Day services, or where you expect a silence of up to 2 minutes to be broadcast. The maximum silence time is set whilst the contact is latched.

Pin 9 is used to remotely start an external piece of equipment and operates on audio fail.

### GPI/O Connector

There are 6 GPI pins available on a 9 way female D-type connector located above the Remote Alarms Connector. These pins have been included to provide more customised behaviour of the RB-SD1IP which could enable non-networked hardware to generate alarms for an existing Network Management System by using the network interface of the RB-SD1IP.

Currently each of the GPI pins can be used to trigger one or both of the relays available to the Remote Alarms Connector. Each GPI can also generate SNMP traps to follow pin activity.

Power and ground connections are available on this connector from the same source as the 200mA +5V fused supply on the Remotes connector.

Pin No.	Signal	I/O	Description
Pin 1	GPI 1	I	General Purpose Input 1
Pin 2	GPI 3	I	General Purpose Input 3
Pin 3	GPI 5	I	General Purpose Input 5
Pin 4	Digital Ground	-	Ground Return For External Circuits
Pin 5	+5V D Fused	-	5V Supply Pin to Power External Circuits
Pin 6	GPI 2	I	General Purpose Input 2
Pin 7	GPI 4	I	General Purpose Input 4
Pin 8	GPI 6	I	General Purpose Input 6
Pin 9	Digital Ground	7	Ground Return for External Circuits

### Ethernet Connector

The unit supports 10/100 Mbps Ethernet via a standard RJ45 connector. The Green LED shows link status/activity and the Amber LED indicates connection speed (On = 100 Mbps, Off = 10 Mbps).

A Webserver is built into the RB-SD1IP to allow easier configuration and remote operation.

## Front Panel Selectors and Indicators

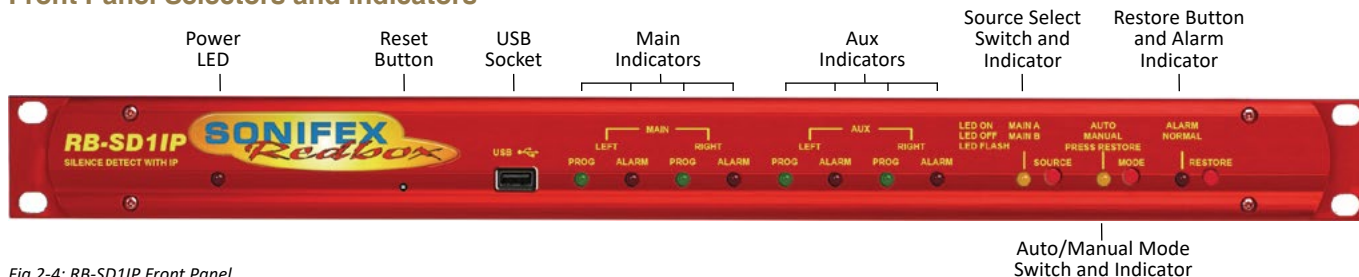

Fig 2-4: RB-SD1IP Front Panel

### Power Indicator

A single red LED confirms the presence of an active power supply to the unit.

### Reset Button

The recessed reset button allows you to perform a hardware reset on the unit without powering down.

### USB Port

The USB port enables the unit to act as a host for low power mass storage devices (such as flash drives) which are formatted to either FAT or FAT32. Such devices may be used for the playback of audio files.

The USB functionality is configured using the browser based GUI and allows you to play out wave (.wav) files in the event of both the Main and Auxiliary sources falling silent. The currently supported file format is .wav extensions in PCM 16 bit Stereo encoding.

The unit supports the following sample rates: 8 kHz, 11.025 kHz, 12 kHz, 16 kHz, 22.050 kHz, 24 kHz, 32 kHz, 44.1 kHz, 48 kHz

Only files located in the root directory of the USB device will be available for playback. The unit supports a playlist in the form of an ordered list of filenames delineated by a new line.

For example:

Track\_05.wav

Track\_01.wav

03\_Song.wav

Melody.mp3

customer\_message.wav

The playlist file should be designated “playlist.txt” or “playlist.m3u” and placed in the root directory with the audio files. Any files in the list which are invalid (such as the .mp3 in the above example) or not present will be ignored. If a playlist is not present then the audio files will be played out in the order of their creation on the USB device.

**Note:** It is recommended that files of a single sample rate range are used in order to avoid a small delay (up to 3 seconds) between the playback of tracks with sample rates in different frequency ranges.

The USB audio playback feature can be remotely enabled or disabled using the GUI. Other USB audio options include: Default Sample Rate Selection, Track Recall, Looped Playback and SNMP Trap Generation.

### Default Sample Rate:

This option sets up the system clock to be ready to play out files with a sample rate from a specific frequency range. For example; if your USB

device contains files at a sample rate of 24 kHz, set the default sample rate to 48 kHz range, which also supports the subfrequencies 12kHz & 24kHz, to ensure the unit always boots up ready to play at the correct clock frequency.

#### Track Recall:

When this option is disabled, every time USB audio is routed to the output, the playback will begin from the first available file. When this option is enabled the unit will remember the previous track it was playing out from USB and upon USB audio being routed to the output, playback will begin from the start of the next available file. Note that Track Recall will be lost when the unit is powered down, or when the USB device is removed.

#### Looped Playback:

When enabled, this option will play all valid audio files on the USB device in a loop whenever USB audio is route to the output. When this option is disabled the audio files on the USB device will only be played through once, per instance, of the USB audio being routed to the output.

#### SNMP Trap Generation:

The unit can generate SNMP Traps to inform a Network Management System (NMS) that a USB device has been plugged into, or unplugged from the front of the unit.

#### Main and Aux Indicators

On the front panel there are four Main indicators and four Aux indicators. Each left/right channel has a Program Content and Alarm Status indicator. The Program Content Indicator represents the input signal level for that channel and the Alarm Status LED indicates whether the channel has dropped below the threshold for longer than the time selected.

Both the Main and Aux inputs are continuously monitored so that you can check that your backup signal is operating correctly, as well as your main input source.

**Note:** Although one channel of the stereo input may have alarmed, the main alarm may not be set, due to the setting of the Stereo/Mono Dipswitch.

#### Source Select and Indicator

The preferred Main input source is selectable via a recessed push button switch on the front panel, or it can be controlled remotely (pin 10) and from the GUI. This allows you to define whether input A, or input B is going to be the Main audio input. There is an LED to indicate which state the source select is in:

LED	Description
LED On	Main source is input A, Aux source is input B
LED Off	Main source is input B, Aux source is input A

The GUI can be used to configure the source select LED to indicate the current input which is being routed to the output. In this case:

LED	Description
LED On	Input A is being routed to the output
LED Off	Input B is being routed to the output
LED Flashing	USB Audio is being routed to the output

**Note:** If the unit is powered off, for example during a black-out, input A routes through to the output. Therefore if the unit is subject to a power fail while the main source is set to input B, the unit will output source A.

#### Auto/Manual Mode Selector and Indicator

The Auto/Manual Mode Switch defines how the unit should operate during an alarm condition, when the main audio source returns. There is an option to allow the device to switch back Automatically or Manually. The mode is selected by a push switch accessed through a hole on the front panel with a corresponding LED to represent its state, it can be controlled remotely (pins 3 and 4) or by using the GUI.

LED	Description
LED On	Automatic Mode – During an alarm condition when the main source returns, it is switched back automatically, although a valid signal must persist for at least the configured Restore Time period.
LED Off	Manual Mode – the LED will begin to flash once a valid main signal is detected, indicating that manual restore can now be performed.
LED Flashing	Manual Mode – The main audio has returned after an alarm condition. To switch to the main source, push the Restore button (or control it remotely).

**Note:** When using Independent Channels in Manual Mode you will need to press restore once for each channel.

#### Restore Alarm Indicator

The Restore Alarm Indicator situated on the front panel is used to display the alarm status of the Main input. Its operation is dependent on the selected mode (See Mode DIP Switch Settings):

- Stereo mode - the unit alarms on a single main channel timeout.
- Mono mode - alarms on both main channels timing out.

The unit exits the alarm state on the return of the main source signal, depending on the setting of the Stereo/Mono Dipswitch.

#### Restore Button

The Restore button is used for restoring the main source signal when the unit is operating in Manual Mode. When the main source signal returns after it has timed out, the Mode LED flashes, indicating that the source signal can be restored. When the Restore button is pressed the main source returns. This can be remotely controlled using pin 2 of the remotes connector. There is also a restore button present on the web based GUI.

#### Reset to Defaults

It is possible to reset the unit to default configuration settings, including network settings, from the front panel. To perform a full reset you must press and hold the Restore button whilst resetting or power cycling the unit.

#### Physical Configuration

It is possible to force the unit to use physical configurations (rear panel dip & hex switches) rather than the browser based GUI settings. To do this you must press and hold the Source Select button whilst resetting or power cycling the unit.

**Note:** When switching to physical configuration from webpage configuration, the operation of the unit could change significantly.

#### Boot Mode

In the unlikely event that the RB-SD1IP becomes inoperable due to corruption of the main firmware, you can force the unit into Boot Mode. To do this you must hold down both the Source Select and Mode buttons whilst resetting or power cycling the unit. To indicate that Boot Mode is active the Source, Mode and Restore LEDs will flash. A unit in “Boot Mode” can be discovered and updated through the webpage in the same way as for main firmware.

#### Additional Modes

The original RB-SD1 offered the option to configure the unit into various additional modes of operation. The RB-SD1IP offers these options through a webserver based GUI.

## RB-SD1IP Network Discovery and Webserver

In addition to any physical controls the RB-SD1IP has a built in webserver which can allow you to control and configure the unit remotely through a web browser. The webpage interface also enables you to view status information, alter network settings, and update product firmware.

The RB-SD1IP network interface employs Zeroconf networking, meaning that it supports DHCP, AutoIP and MDNS-SD using Bonjour. We provide a free application available for download from our website ([www.sonifex.co.uk/technical/software](http://www.sonifex.co.uk/technical/software)) to facilitate the discovery and use of Sonifex network enabled hardware, see below for more information.

**Connecting to the unit:** Connecting to the webpage interface is as simple as typing the IP address of the unit into the address bar of a web browser on a PC connected to the same network.

### DHCP

The RB-SD1IP will have DHCP and AutoIP enabled by default, if your network has a DHCP server then the unit will be assigned an IP address which can be found easily by using the Sonifex service discovery application, or by contacting your network administrator. The nature of DHCP means that the unit is not guaranteed to maintain a fixed IP address each time it is reconnected to the network. See the section on static network settings below for information on how to fix the IP address of the unit.

### AutoIP

If your network does not support DHCP or it is disabled, then with AutoIP enabled the unit will assign itself an IP address from the AutoIP range (169.254.1.0 to 169.254.254.255). Once an AutoIP address has been assigned you will need to connect the unit directly to a PC using an Ethernet cable. Ensure that the PC has dynamic addressing enabled and you will be able to use the Sonifex discovery application on this mini network to access the webpage interface.

### Static Network Settings

Accessing the webpage interface allows you to configure the network settings as you like. To give the unit a fixed network address, enter appropriate static details and disable both DHCP and AutoIP. The unit will now apply the static network settings whenever it is connected to a network.

### MDNS-SD and Bonjour

Bonjour is a hardware discovery service developed by Apple and as such it is natively supported by Apple devices and operating systems. Bonjour for Windows is available, go to our website ([www.sonifex.co.uk/technical/software](http://www.sonifex.co.uk/technical/software)) or other download stores and download the appropriate version for your operating system.

On a Bonjour enabled device or system, you can connect to a unit using only its hostname. By default the hostname for the RB-SD1IP will be the hardware ID appended by the unique serial number of the unit:

**[Hardware ID] – [Serial No.]**

**RB-SD1IP-654321**

To connect to a unit using Bonjour you can simply discover and launch the webpage interface from the Sonifex service discovery application. Alternatively you can simply type the hostname appended by the local domain name into the address bar of your web browser, for the example above you would enter the following:

**RB-SD1IP-654321.local.**

The hostname is independent of the IP address and this means that the unit can always be discovered and accessed in this way, regardless of which IP address it has been assigned by a DHCP server. The hostname can be changed to make it more memorable or descriptive of an implementation, however, conflicting names should be avoided.

### Sonifex Service Discovery App

This is a free download for Windows, available from our website ([www.sonifex.co.uk/technical/software](http://www.sonifex.co.uk/technical/software)). This application uses Bonjour to locate networked hardware and discover what services it has to offer. On a device

or system running Bonjour you can discover Sonifex hardware and launch the webserver interface if available. The application also offers legacy discovery for systems which do not support Bonjour or for Sonifex hardware which is not running MDNS-SD.

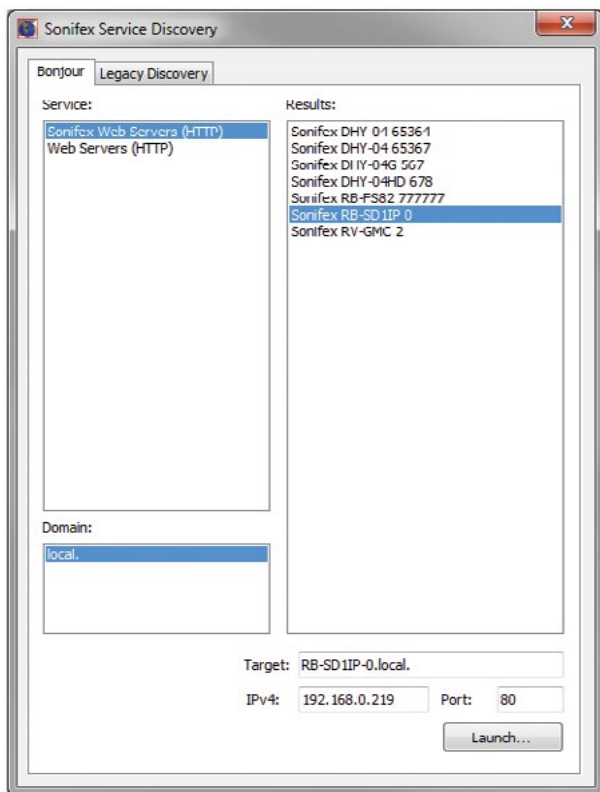

Fig 2-5: Sonifex Service Discovery - Bonjour Page

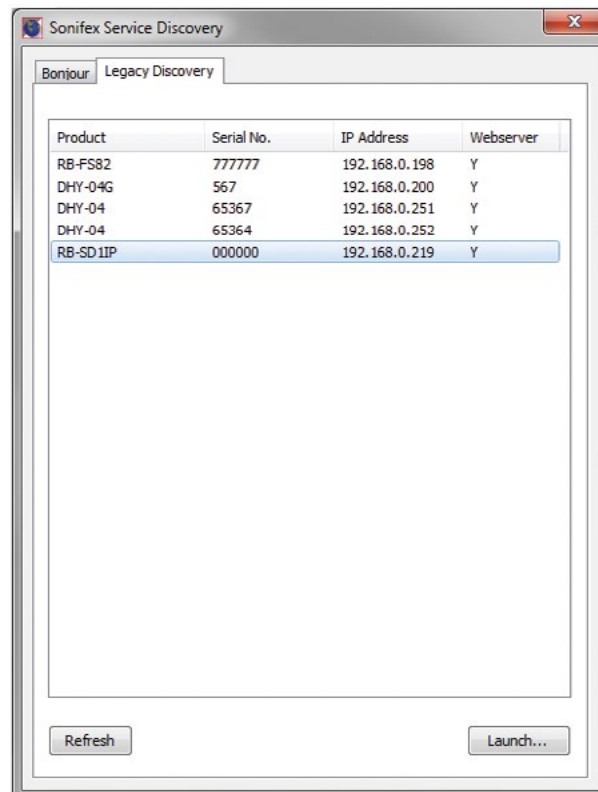

Fig 2-6: Sonifex Service Discovery - Legacy Discovery Page

**SONIFEX**  
Manufacturers of audio & video equipment for radio & TV studios

**RB-SD1IP**  
Web Server

Home | Device Info | Network | Configuration | Update | Set to Defaults

**Home**

	Main Left	Main Right	Aux Left	Aux Right
<b>Signal Level:</b>	-60dBu	-60dBu	100dBu	70dBu
<b>Silence Level:</b>	-150dBu	-150dBu	-150dBu	-150dBu
<b>Alarm Status:</b>	<span style="color:red">■</span>	<span style="color:red">■</span>	<span style="color:green">■</span>	<span style="color:green">■</span>
<b>Force Output:</b>	<input type="button" value="A"/> <input type="button" value="B"/> <input type="button" value="USB"/>			
	<b>Left</b>	<b>Right</b>		
<b>Signal Output:</b>	Aux	Aux		
	<input type="button" value="Restore"/>			
<b>Configuration:</b>	Physical			
<b>Silence Time Override :</b>	Inactive			
<b>Override Time :</b>	2m 5s			

**Home Page**

**Signal Level**  
The approximate current audio level for each channel.

**Silence Level**  
The current silence detection level for each channel.

**Alarm Status**  
Alarm Indicator for each channel where green is a Valid Signal and red is a Silence Alarm.

**Force Output**  
Forces the output signal to A, B or USB sources. Use Unlock to revert to normal operation.

**Signal Output**  
This indicates the signal which is currently being routed to the left and right output channels. If the outputs have been locked by the remote source select pin or by the SNMP interface this will be indicated to the right of the signal output.

**Restore**  
This button works in the same way as the front panel Restore button, to bring back a valid Main audio signal in Manual Mode.

**Configuration**  
When in Physical configuration mode, various settings within the webpage are overridden by the hardware switches on the back panel of the unit. The configuration mode can be changed on the Physical Settings webpage.

**Override Time Active**  
This indicates whether the silence detection override has been activated by the remote connector or the SNMP interface.

Sonifex Ltd. 61 Station Road, Irthlingborough, Northants, NN9 5QE, UK. Tel: +44 (0)1933 650700 Fax: +44 (0)1933 650726 E-Mail: [sales@sonifex.co.uk](mailto:sales@sonifex.co.uk)

Fig 2-7: RB-SD1IP Screenshot of the Webserver Home Page

The web based GUI has a menu bar that allows you to navigate through various pages to configure different aspects of the unit. Each page follows the same standard layout as the Home page, with current status/configuration settings on the left and tooltip explanations in the box on the right. The page footer contains contact details for Sonifex Ltd.

## Home Page

### Signal Level

The approximate current audio level for each channel.

### Silence Level

The current silence detection level for each channel.

### Alarm Status

Alarm Indicator for each channel where green is a Valid Signal and red is a Silence Alarm.

### Force Output

These three buttons allow the user to force the output signal to either the A, B or USB inputs. When the output signal is forced, an unlock button is visible. This will revert the unit back to normal operation.

### Signal Output

This indicates the signal which is currently being routed to the left and right output channels. If the outputs have been locked by the remote source select pin or by the SNMP interface this will be indicated to the right of the signal output.

### Restore

This button works in the same way as the front panel Restore button, to bring back a valid Main audio signal in Manual Mode.

### Configuration

When in Physical configuration mode, various settings within the webpage are overridden by the hardware switches on the back panel of the unit. The configuration mode can be changed on the Physical Settings webpage.

### 2 Minute Silence

This indicates whether the 2 minute silence detection override has been activated by the remote connector or the SNMP interface.

**SONIFEX**  
*Redbox*

**SONIFEX**  
Manufacturers of audio & video  
equipment for radio & TV studios

**RB-SD1IP**  
Web Server

Home | Device info | Network | Configuration | Update | Set to Defaults

### Device Info

Device: RB-SD1IP  
Serial Number: 0  
Description: Redbox Silence Detector IP Enabled  
Firmware Version: v01.24.169

### Network Info

Connectivity: Static - 100Mbps  
Host Name: RB-SD1IP-0  
Actual IP Address: 192.168.8.100  
Actual Subnet Mask: 255.255.255.0  
Actual Gateway IP: 192.168.8.1  
Hardware Address: 00.50.C2.05.AE.37

### Device Information

This page shows general information about the connected RB-SD1IP.

Sonifex Ltd. 61 Station Road, Irthlingborough, Northants, NN9 5QE, UK. Tel: +44 (0)1933 650700 Fax: +44 (0)1933 650726 Email: [sales@sonifex.co.uk](mailto:sales@sonifex.co.uk)

## Device Information

This page shows general information about the connected RB-SD1IP.

Fig 2-8: RB-SD1IP Screenshot of the Webservice Device Page

**SONIFEX**  
Manufacturers of audio & video equipment for radio & TV studios

**RB-SD1IP**  
Web Server

Home | Device Info | Network | Configuration | Update | Set to Defaults

### Network Settings

**Host Name:**

**IP Address:**

**Netmask:**

**Gateway:**

**Dynamic Addressing:**  DHCP Enabled  
 Auto IP Enabled

**HTTP Port:**

**New Password:**

**Retype Password:**

**Network Settings**

**Host Name**  
The Host Name for this unit is used for Multicast DNS Service Discovery. The default Host Name is the unit Hardware Type, appended with the unique Serial Number.

**IP Address**  
Please enter the static IP Address that you wish to assign to this unit. The address must be in the correct form, the default address is: 192.168.0.100

**Netmask**  
Please enter the Netmask of the network you wish to connect to. The default subnet mask is: 255.255.255.0

**Gateway Address**  
Please enter the Gateway Address of your router. The default gateway address is: 192.168.0.149

**Dynamic Addressing**  
Enable Dynamic Addressing or disable to force the use of the static network settings entered above. When enabled, DHCP and AutoIP are used, the unit will use AutoIP until DHCP server is detected.

**HTTP Port**  
The webserver port number should be between 1024 and 65535, or 80. NOTE: Unit must be rebooted after this setting is changed.

**Password**  
The password should be between 4 and 8 characters in length and contain only letters and numbers. When logging in, the user name is always admin.

Sonifex Ltd. 61 Station Road, Irthlingborough, Northants, NN9 5QE, UK. Tel: +44 (0)1933 650700 Fax: +44 (0)1933 650726 Email: [sales@sonifex.co.uk](mailto:sales@sonifex.co.uk)

Fig 2-9: RB-SD1IP Screenshot of the Webserver Network Settings Page

## Network Settings

### Host Name

The Host Name for this unit is used for Multicast DNS Service Discovery. The default Host Name is the unit Hardware Type, appended with the unique Serial Number.

### IP Address

Please enter the static IP Address that you wish to assign to this unit. The address must be in the correct form, the default address is: 192.168.0.100

### Netmask

Please enter the Netmask of the network you wish to connect to. The default subnet mask is: 255.255.255.0

### Gateway Address

Please enter the Gateway Address of your router. The default gateway address is: 192.168.0.149

### Dynamic Addressing

Enable Dynamic Addressing or disable to force the use of the static network settings entered above. When enabled, DHCP and AutoIP are used, the unit will use AutoIP until DHCP server is detected.

### HTTP Port

Configures the port which the webserver listens on. This can be set to port 80, or a number between 1024 and 65535. The unit must be restarted for this setting to take effect.

### Password

It is possible to setup password access to the unit's webserver. To add a password, simply enter a new password in the New Password entry box and re-type it in the Retype Password entry box. The password should be between 4 and 8 characters in length and contain only letters and numbers. After submission, the user will be required to enter this password to gain access to the device. The username is always admin.

**SONIFEX**  
Manufacturers of audio & video equipment for radio & TV studios

**RB-SD1IP**  
Web Server

Home | Device info | Network | Configuration | Update | Set to Defaults

### Levels & Times

**Select Channel:** A Left

**Silence Level:** -15dBu

**Silence Time:** 0 : 0 : 5 Secs

**Restore Time:** 0 : 0 : 2 Secs

**Alarm Trap:**  Enable  Disable

**Valid Trap:**  Enable  Disable

**Line Level:**  Consumer - Single Ended  Professional - Differential

**Override Time:** 0 : 2 : 5 Secs

submit

**Level & Time Settings**

Select the channel you wish to configure from the drop down list and change its settings as required. Once you have configured all channels, hit submit.

**Silence Level**  
Select the desired audio level to be treated as silence.

**Silence Time**  
Enter the desired length of time for which the signal must be below the selected Silence Level, before an alarm is triggered. (Format; Hrs : Mins : Secs)

**Restore Time**  
Enter the desired length of time for which a signal above the selected Silence Level must persist, before an alarm state is cancelled. (Format; Hrs : Mins : Secs)

**Alarm / Valid Traps**  
Choose to enable or disable SNMP Trap generation following changes in alarm state for each channel. The Alarm Trap will be generated when the signal status becomes alarmed. The Valid Trap will be generated when the signal status changes from alarmed back to normal. The destinations for traps can be configured on the SNMP configuration page.

**Line Level**  
Channels B Left and B Right have an optional extra +8dB of gain to allow for the connection of single ended, consumer equipment, for these channels you may select the appropriate line level.

**Override Time**  
When the override time is requested from the remote connector or by SNMP the silence timeout is changed to this value - default is 2min 5sec.

NOTE: All options may be configured at any time. Options which are greyed out are currently not enforced due to other settings, such as the Physical Config option.

Sonifex Ltd. 61 Station Road, Irthlingborough, Northants, NN9 5QE, UK. Tel: +44 (0)1933 650700 Fax: +44 (0)1933 650726 Email: [sales@sonifex.co.uk](mailto:sales@sonifex.co.uk)

Fig 2-10: RB-SD1IP Screenshot of the Webserver Level & Time Settings Page

## Configuration : Level & Time Settings

Select the channel you wish to configure from the drop down list and change its settings as required. Once you have configured all channels, hit submit.

### Silence Level

Select the desired audio level to be treated as silence.

### Silence Time

Enter the desired length of time for which the signal must be below the selected Silence Level, before an alarm is triggered. (Format; Hrs : Mins : Secs)

### Restore Time

Enter the desired length of time for which a signal above the selected Silence Level must persist, before an alarm state is cancelled. (Format; Hrs : Mins : Secs)

### Alarm / Valid Traps

Choose to enable or disable SNMP Trap generation following changes in alarm state for each channel. The Alarm Trap will be generated when the signal status becomes alarmed. The Valid Trap will be generated when the signal status changes from alarmed back to normal. The destinations for traps can be configured on the SNMP configuration page.

### Line Level

Channels B Left and B Right have an optional extra +8dB of gain to allow for the connection of single ended, consumer equipment, for these channels you may select the appropriate line level.

**Note:** All options may be configured at any time. Options which are greyed out are currently not enforced due to other settings, such as the Physical Config option.

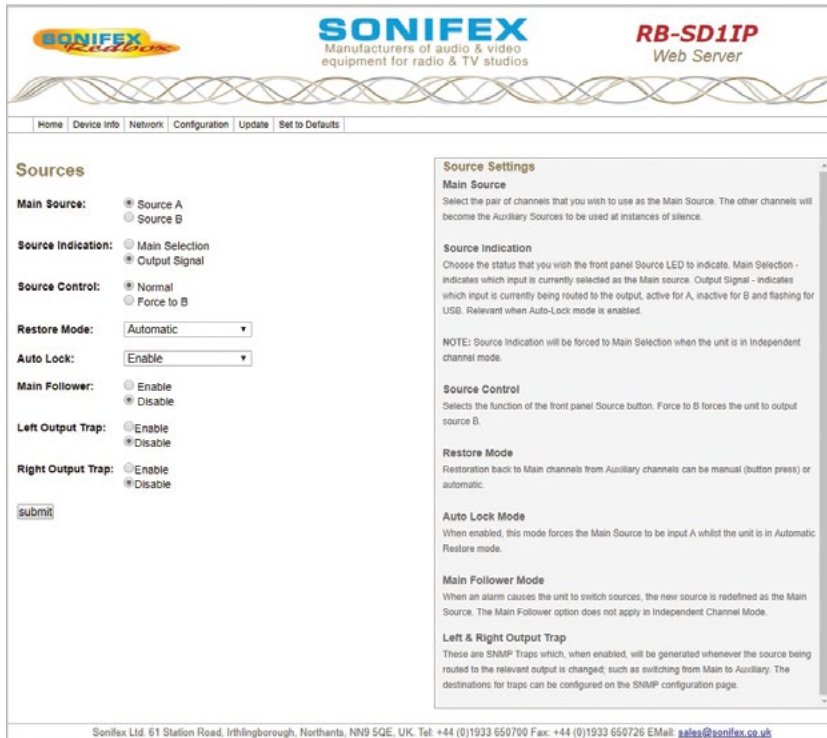

Fig 2-11: RB-SD1IP Screenshot of the Webserver Sources Page

## Configuration : Source Settings

### Main Source

Select the pair of channels that you wish to use as the Main Source. The other channels will become the Auxiliary Sources to be used at instances of silence.

### Source Indication

Choose the status that you wish the front panel Source LED. Main Selection - indicates which input is currently selected as the Main source. Output Signal - indicates which input is currently being routed to the output, active for A, inactive for B and flashing for USB.

**Note:** Source Indication will be forced to Main Selection when the unit is in Independent channel mode.

### Source Control

Selects the operation of the front panel source control button. In normal mode this selects whether the main source is input A or input B. When set to Force to B, then this control will force the unit to route stereo source B to the outputs.

### Restore Mode

Restoration back to Main channels from Auxiliary channels can be manual (button press) or automatic.

### Auto Lock Mode

When enabled, this mode forces the Main Source to be input A whilst the unit is in Automatic Restore mode.

### Main Follower Mode

When an alarm causes the unit to switch sources, the new source is redefined as the Main Source. The Main Follower option does not apply in Independent Channel Mode.

### Left & Right Output Trap

These are SNMP Traps which, when enabled, will be generated whenever the source being routed to the relevant output is changed; such as switching from Main to Auxiliary. The destinations for traps can be configured on the SNMP configuration page.

**Alarms**

Channel Mode:

Stereo Alarm:  No Action  
 Switch Both Channels

Mono Alarm:  No Action  
 Switch Both Channels

Independent Alarms:

Left:  No Action  
 Switch Left Channel

Right:  No Action  
 Switch Right Channel

Fast Restore:  Enable  
 Disable

**Alarm Settings**

**Channel Mode**  
 Control how alarm signals are handled with regard to audio switching:

**Stereo** - both Main channels are required, the unit will attempt to switch sources if either falls silent.

**Mono** - only one Main channel is required, the unit will only attempt to switch to Auxiliary if both Main channels fall silent.

**Independent** - channel switching is handled separately, silence on Main left/right channel will only switch in the left/right Aux respectively.

**Alarm Actions**  
 You can configure the action that the unit will take in each channel mode, when an alarm is triggered.

**Fast Restore**  
 Fast Restore Mode automatically lowers the Restore times to a minimum value in instances where all sources are Alarmed. This can allow the unit to restore audio faster and avoid dead air for longer than necessary.

NOTE: All options may be configured at any time. Options which are greyed out are currently not enforced due to other settings, such as the Physical Config option.

Sonifex Ltd. 61 Station Road, Irthlingborough, Northants, NN9 5QE, UK. Tel: +44 (0)1933 650700 Fax: +44 (0)1933 650726 Email: [sales@sonifex.co.uk](mailto:sales@sonifex.co.uk)

Fig 2-12: RB-SD1IP Screenshot of the Webserver Alarms Page

## Configuration : Alarm Settings

### Channel Mode

Control how alarm signals are handled with regard to audio switching:

**Stereo** - both Main channels are required, the unit will attempt to switch sources if either falls silent.

**Mono** - only one Main channel is required, the unit will only attempt to switch to Auxiliary if both Main channels fall silent.

**Independent** - channel switching is handled separately, silence on Main left/right channel will only switch in the left/right Aux respectively.

### Alarm Actions

You can configure the action that the unit will take in each channel mode, when an alarm is triggered.

### Fast Restore

Fast Restore Mode automatically lowers the Restore times to a minimum value in instances where all sources are Alarmed. This can allow the unit to restore audio faster and avoid dead air for longer than necessary.

**Note:** All options may be configured at any time. Options which are greyed out are currently not enforced due to other settings, such as the Physical Config option.

**SONIFEX**  
Manufacturers of audio & video equipment for radio & TV studios

**RB-SD1IP**  
Web Server

Home | Device Info | Network | Configuration | Update | Set to Defaults

### SNMP

Community String:

Destination IP 1:

Destination IP 2:

Destination IP 3:

Destination 1:  Enabled  Disabled

Destination 2:  Enabled  Disabled

Destination 3:  Enabled  Disabled

**SNMP Settings**

This page allows you to configure the SNMP community string and SNMP Trap destinations. The traps themselves are enabled on the relative webpages, for example GPI and Levels & Times.

**Community String**

The Community String may be up to 20 characters long.

**Trap Destination IP Addresses**

You can set up to 3 different IP addresses which will receive all traps generated by the unit. Each destination can be enabled or disabled individually.

**NOTE:** The default Community String is "public", it is recommended that you change this to make it harder to guess, or descriptive of the implementation. However, SNMP Version 1 community strings are not secure, they are sent as raw bytes over the network, there is no encryption.

Sonifex Ltd. 61 Station Road, Irthlingborough, Northants, NN9 5QE, UK. Tel: +44 (0)1933 650700 Fax: +44 (0)1933 650726 EMail: [sales@sonifex.co.uk](mailto:sales@sonifex.co.uk)

Fig 2-13: RB-SD1IP Screenshot of the Webserver SNMP Page

## Configuration : SNMP Settings

This page allows you to configure the SNMP community string and SNMP Trap destinations. The traps themselves are enabled on the relative webpages, for example GPI and Levels & Times.

### Community String

The Community String may be up to 20 characters long.

### Trap Destination IP Addresses

You can set up to 3 different IP addresses which will receive all traps generated by the unit. Each destination can be enabled or disabled individually.

**Note:** The default Community String is "public", it is recommended that you change this to make it harder to guess, or descriptive of the implementation. However, SNMP Version 1 community strings are not secure, they are sent as raw bytes over the network, there is no encryption.

**USB**

**USB Audio:**  Enable  
 Disabled

**Default Rate:**  32 kHz  
 44.1 kHz  
 48 kHz

**Track Recall:**  Enable  
 Disabled

**Playback:**  Once  
 Looped

**Plugged:**  Enabled  
 Disabled

**Unplugged:**  Enabled  
 Disabled

**USB Settings**

**USB Audio**  
Enable or disable the use of USB Audio as a secondary back up source, to be switched in when both Main and Aux sources are silent.

**Default Rate**  
We recommend that a USB device is loaded with files which are all in the same frequency range (e.g. 48 kHz, 24 kHz and 12 kHz), this will avoid any detection or playback delays between tracks as the internal clock is adjusted for different sample rates. This option allows you to select the sample rate range that you wish the unit to initialize with. The unit will still play files of any sample rate (8 - 48 kHz) regardless of this setting. See handbook for more details regarding sample rates and delays.

**Track Recall**  
Enabling this option prevents the unit from starting at the first track every time USB audio is switched in. The unit will instead play out the next available track.

**Playback Mode**  
Choose to either loop the playback of the audio files on the USB device, or to only play through once.

**Plugged / Unplugged Trap**  
Enable or disable the generation of an SNMP Trap when a USB device is plugged into or unplugged from the unit.

**NOTE:** The destinations for traps can be configured on the SNMP configuration page.

Sonifex Ltd. 61 Station Road, Irthlingborough, Northants, NN9 5QE, UK. Tel: +44 (0)1933 650700 Fax: +44 (0)1933 650726 Email: [sales@sonifex.co.uk](mailto:sales@sonifex.co.uk)

Fig 2-14: RB-SD1IP Screenshot of the Webserver USB Page

## Configuration : USB Settings

### USB Audio

Enable or disable the use of USB Audio as a secondary back up source, to be switched in when both Main and Aux sources are silent.

### Default Rate

We recommend that a USB device is loaded with files which are all in the same sample frequency range (e.g. 48 kHz, 24 kHz and 12 kHz), this will avoid any detection or playback delays between tracks as the internal clock is adjusted for different sample rates.

This option allows you to select the sample rate range that you wish the unit to initialize with. The unit will still play files of any sample rate (8 - 48 kHz) regardless of this setting. See handbook for more details regarding sample rates and delays.

### Track Recall

Enabling this option prevents the unit from starting at the first track every time USB audio is switched in. The unit will recall the track that was previous playing, and play out the next available track.

### Playback Mode

Choose to either loop the playback of the audio files on the USB device, or to only play through once.

### Plugged / Unplugged Trap

Enable or disable the generation of an SNMP Trap when a USB device is plugged into or unplugged from the unit.

**Note:** The destinations for traps can be configured on the SNMP configuration page.

**SONIFEX**  
Manufacturers of audio & video equipment for radio & TV studios

**RB-SD1IP**  
Web Server

Home | Device Info | Network | Configuration | Update | Set to Defaults

### Remotes

**Remote Controls:**  Unlocked  Locked

**Source Indication:**  Main Selection  Output Signal

**Remote Start:**  Momentary  Latching

**Remote Start Trigger:** Main Pair

**Relay 1 Engage:** On Either Main Alarm

**Relay 2 Engage:** On Either Aux Alarm

**Relay Invert State:**  Active on Alarm/Error  Active when Normal/No Error

**Remote Settings**  
This page allows you to configure how you would like the pins on the rear panel, 15 way, remote connector to behave.

**Remote Controls**  
This allows you to Lock or Unlock Pins 5, 7, 10 and 14. Preventing (or allowing) connected hardware to trigger Modes, Restore, Max Silence Time and Source Select.

**Source Indication**  
Choose the status that you wish the remote Source Select pin to indicate. Main Selection - indicates which input is currently selected as the Main source. Output Signal - indicates which input is currently being routed to the output, active for A, inactive for B or USB. Relevant when Auto-Lock mode is enabled.

NOTE: Source Indication will be forced to Main Selection when the unit is in independent channel mode.

**Remote Start**  
The Remote Start Pin 15 is pulled low when the selected trigger occurs. This pin can either be latched low for the duration of the alarm, or only held low for 500ms.

**Remote Start Trigger**  
Select the alarm on which you would like remote start to be triggered.

**Remote Relay Action**  
Select the condition on which you would like each remote relay to engage.

**Invert Relay Action**  
Select this option to invert the action of the remote relays. Normally a relay becomes active on an Alarm or Error condition. This alternative function means that the relay becomes active at start up until an alarm or error condition occurs when it becomes inactive. This means that a power fail will also cause a relay 'fail' condition.

Sonifex Ltd. 61 Station Road, Irthlingborough, Northants, NN9 5QE, UK. Tel: +44 (0)1933 650700 Fax: +44 (0)1933 650726 EMail: [sales@sonifex.co.uk](mailto:sales@sonifex.co.uk)

Fig 2-15: RB-SD1IP Screenshot of the Webserver Remotes Page

## Configuration : Remote Settings

This page allows you to configure how you would like the pins on the rear panel, 15 way, remote connector to behave.

### Remote Controls

This allows you to Lock or Unlock Pins 5, 7, 10 and 14. Preventing (or allowing) connected hardware to trigger Modes, Restore, Max Silence Time and Source Select.

### Source Indication

Choose the status that you wish the remote Source indicator to indicate. Main Selection – indicates which input is currently selected as the Main source. Output Signal – indicates which input is currently being routed to the output, active for A, inactive for B or USB.

### Remote Start

The Remote Start Pin 15 is pulled low when the selected trigger occurs. This pin can either be latched low for the duration of the alarm, or only held low for 500ms.

### Remote Start Trigger

Select the alarm on which you would like remote start to be triggered.

### Remote Relay Action

Select the condition on which you would like each remote relay to engage.

**Note:** If you select a GPI pin as a relay trigger, you will need to set up the GPIO options accordingly, otherwise the relay may not engage.

**Note:** All options may be configured at any time. Options which are greyed out are currently not enforced due to other settings, such as the Physical Config option.

**SONIFEX**  
*Redbox*

**SONIFEX**  
Manufacturers of audio & video  
equipment for radio & TV studios

**RB-SD1IP**  
Web Server

Home | Device Info | Network | Configuration | Update | Set to Defaults

### GPIO

Select GPIO: 1

Active Level:  
 Low  
 High

Active Trap:  
 Enable  
 Disable

Inactive Trap:  
 Enable  
 Disable

**GPIO Settings**

This page allows you to set up and configure the 6 General Purpose Inputs (GPI) on the rear panel, 9 way port. Select the GPI that you wish to configure from the drop down list. You can configure all 6 of the pins before hitting submit.

**Active Level**  
Select the active level for the GPI.

**Active / Inactive Trap**  
SNMP Traps can be generated when each GPI becomes active and or inactive. You can enable / disable each trap individually. The destinations for traps can be configured on the SNMP configuration page.

Sonifex Ltd. 61 Station Road, Irthlingborough, Northants, NN9 5QE, UK. Tel: +44 (0)1933 650700 Fax: +44 (0)1933 650726 Email: [sales@sonifex.co.uk](mailto:sales@sonifex.co.uk)

## Configuration : GPIO Settings

This page allows you to set up and configure the 6 General Purpose Inputs (GPI) on the rear panel, 9 way port. Select the GPI that you wish to configure from the drop down list. You can configure all 6 of the pins before hitting submit.

### Active Level

Select the active level for the GPI.

### Active / Inactive Trap

SNMP Traps can be generated when each GPI becomes active and or inactive. You can enable / disable each trap individually. The destinations for traps can be configured on the SNMP configuration page.

Fig 2-16: RB-SD1IP Screenshot of the Webserver GPIO Page

**SONIFEX**  
Manufacturers of audio & video equipment for radio & TV studios

**RB-SD1IP**  
Web Server

Home | Device Info | Network | Configuration | Update | Set to Defaults

### Physical Settings

**Silence Level:** -15 dBu  
**Silence Time:** 2 Seconds  
**Input B - Line Level:** Professional Balanced  
**Alarm Mode:** Stereo  
**Remote Start Pin:** Momentary  
**Audio Switch:** Switch to Aux

**Configuration:** Webpage

**Front Panel:**  Unlocked  Locked

**Brightness Level:** 3

**Power On Auto:**  Enable  Disable

**Physical Settings**

This page shows you the settings which are currently selected according to the physical switches on the back panel of the unit.

**Configuration**

This option allows you to select whether to use the options set by the physical controls on the unit, or the options set up using this webserver. When using the physical control settings many options on the webpage will become grey to indicate that they are not currently enforced.

**Front Panel**

This option allows you to lock or unlock the use of the three front panel buttons; Source, Mode and Restore.

**Brightness Level**

This option allows you to control the brightness of the LEDs on the front panel of the unit, with 3 being the brightest.

NOTE: You may have to refresh the web page in order to be sure that you are seeing the most current physical settings for this unit.

**Power On Auto**

When enabled, this option enforces certain conditions on unit boot up. The Restore Mode will be set to Automatic, the Auto Lock Mode will be turned on and Source Indication will be set to Output Signal. All other configurations will be retained.

NOTE: The settings affected by Power On Auto may be reconfigured whilst the unit is running. They will only return to the configuration stated above on boot up. Power On Auto will be disabled when the unit is reset to default configuration.

Sonifex Ltd. 61 Station Road, Irthlingborough, Northants, NN9 5QE, UK. Tel: +44 (0)1933 650700 Fax: +44 (0)1933 650726 EMail: [sales@sonifex.co.uk](mailto:sales@sonifex.co.uk)

Fig 2-17: RB-SD1IP Screenshot of the Webserver Physical Settings Page

## Configuration : Physical Settings

This page shows you the settings which are currently selected according to the physical switches on the back panel of the unit.

### Configuration

This option allows you to select whether to use the options set by the physical controls on the unit, or the options set up using this webserver. When using the physical control settings many options on the webpage will become grey to indicate that they are not currently enforced.

### Front Panel

This option allows you to lock or unlock the use of the three front panel buttons; Source, Mode and Restore.

### Brightness Level

This option allows you to control the brightness of the LEDs on the front panel of the unit, with 3 being the brightest.

**Note:** You may have to refresh the web page in order to be sure that you are seeing the most current physical settings for this unit.

### Power On Auto

When enabled, this option enforces certain conditions on unit boot up. The Restore Mode will be set to Automatic, the Auto Lock Mode will be turned on and Source Indication will be set to Output Signal. All other configurations will be retained.

**Note:** The settings affected by Power On Auto may be reconfigured whilst the unit is running. They will only return to the configuration stated above on boot up. Power On Auto will be disabled when the unit is reset to default configuration.

**SONIFEX**  
*Redbox*

**SONIFEX**  
Manufacturers of audio & video  
equipment for radio & TV studios

**RB-SD1IP**  
Web Server

Home Device Info Network Configuration Update Set to Defaults

### Update Firmware

Please visit our [software downloads](#) page for firmware updates.

Choose file No file chosen

Update

**Update**  
The current firmware version on this unit is shown at the top of the page. To find out if there is new firmware for your unit, check our website.

If an update is available, download the latest file from our website in the ".dwn" format.

Browse your computer to locate the appropriate firmware file, once the correct file has been selected, hit submit/update.

**NOTE:** If updated with incorrect or corrupt firmware it may be necessary to recover the unit from boot mode. See the Handbook for details.

Sonifex Ltd. 61 Station Road, Irthlingborough, Northants, NN9 5QE, UK. Tel: +44 (0)1933 650700 Fax: +44 (0)1933 650726 Email: [sales@sonifex.co.uk](mailto:sales@sonifex.co.uk)

Fig 2-18: RB-SD1IP Screenshot of the Webserver Update Firmware Page

## Update

The current firmware version on this unit is shown at the top of the page. To find out if there is new firmware for your unit, check our website.

If an update is available, download the latest file from our website in the ".dwn" format.

Browse your computer to locate the appropriate firmware file, once the correct file has been selected, hit submit/update.

**Note:** If updated with incorrect or corrupt firmware it may be necessary to recover the unit from boot mode. See the Handbook for details.

## Technical Specification RB-SD1IP

### Audio Specification

Maximum Input Level:	+28dBu
Input Impedance:	>100kΩ balanced
Maximum Output Level:	+28dBu
Output Impedance:	As input, except when using unbalanced auxiliary input where output impedance <50Ω
Frequency Response:	20Hz - 20kHz ±0.1dB
Gain:	+8dB (for unbal input B - optional)
Noise:	<-93dB, unity gain, ref +8dBu output for unbal input
Distortion:	As input for balanced input, <0.02% @ 1kHz ref +8dBu output for unbalanced input

### Rear Panel Connections and Controls

Inputs (Main & Auxiliary):	4 x XLR 3 pin female (balanced, auxiliary can be unbalanced)
Output:	2 x XLR 3 pin male (balanced)
Remotes:	15 way D-Type plug
GPIO:	9 way D-Type socket
Alarm Threshold:	-15dBu to -60dBu in 3dB steps via rotary switch 0dBu to -60dBu in 3dB steps via web GUI
Silence Detect Duration:	2 - 30 seconds in 2 second intervals & 125 second option via rotary switch 1 second – 24 hours using web GUI
Detection Type:	Mono or Stereo, via DIP switch Mono, Stereo, or dual mono via web GUI
Silence Switch Defeat:	Disable/enable silence switching, via DIP switch or GUI
Remote Start:	Latched or momentary, via DIP switch or GUI
Ethernet:	10/100Mbps on 1xRJ45 socket with status LEDs

Mains Input:	Filtered IEC, continuously rated 85-264VAC @47-63hz 10W max
Fuse Rating:	Anti-surge fuse 1A 20 x 5mm (250VAC)

### Front Panel Controls and Indicators

Controls (With Indicators):	Source Select, Mode Select and Restore
Indicator:	Program and Alarm indicators for left and right source for both Main and Auxiliary channels, power indicator
Reset:	Recessed push button
USB Port:	1 x USB A socket

### USB

The RB-SD1IP can act as a host for low powered USB Mass Storage devices in order to playback Audio files as an emergency backup system for when both Main and Auxiliary sources fail.

File System(s):	FAT & FAT32
Supported Audio:	.wav extension (16 bit Stereo PCM @ 44.1kHz or 48kHz) 8 kHz, 11.025 kHz, 12 kHz, 16 kHz, 22.050 kHz, 24 kHz, 32 kHz, 44.1 kHz, 48 kHz

**Note:** Additional Audio support may be added in future updates

### Equipment Type

RB-SD1IP	Redbox Silence Detection unit with Ethernet & USB
----------	---

### Physical Specification

Dimensions (Raw):	48cm (W) x 10.8cm (D) x 4.2cm (H) (1U) 19" (W) x 4.3" (D) x 1.7" (H) (1U)
Dimensions (Boxed):	58.5cm (W) x 22.5cm (D) x 7cm (H) 23" (W) x 8.9" (D) x 2.8" (H)
Weight:	Nett: 1.4kg Gross: 2.0kg Nett: 3.1lbs Gross: 4.4lbs

## 3 RB-DSD1 Digital Silence Detection Unit

### Introduction



Fig 3-1: RB-DSD1 Front Panel

The RB-DSD1 digital silence detection unit works in a similar way to the Sonifex RB-SD1 analogue silence detection unit, but has AES/EBU, S/PDIF and Toslink inputs and outputs instead of analogue inputs and output respectively. Designed to switch from one input to another in the event of loss of audio, the unit is ideal at transmitter sites, or after the master output of a studio, to switch in another audio source, or simultaneous broadcast, should a master source fail.

The unit can switch:

- On loss of level of the main input.
- On loss of level on one channel of the main input.
- On loss of synchronisation lock of the main input.

The RB-DSD1 has 2 x digital stereo audio inputs, each one selectable via front panel MAIN and AUX push buttons, from either AES/EBU balanced XLRs, S/PDIF unbalanced phonos or Toslink unbalanced optical inputs. Sample rate converters on each input mean that sources of different sample rates can be used with the output sample rate being defined independently. Each input is user-defined as either the main source or auxiliary source and both sources are monitored for failure, each having a remote failure alarm. The colour of the MAIN and AUX push-buttons indicate which input is the current output channel (green) and which input is the waiting channel (red) input, with a flashing LED indicating loss of synchronisation.

In the event of the main source dropping below a pre-set level for a pre-determined amount of time, the unit will automatically switch through to the auxiliary signal. The silence detect level is adjustable between -39dBfs and -84dBfs in 3dBfs steps via front panel DIPswitches. The silence interval can be adjusted between 0 seconds and 252 seconds in 2 second steps via another front panel DIPswitch block. A small cover panel can be screwed in place to obscure the DIPswitches to prevent tampering of the settings.

There are 2 stereo outputs to allow for distribution of the selected input to multiple outputs. Each output is available as simultaneous AES/EBU balanced XLRs, S/PDIF unbalanced phonos or Toslink unbalanced optical outputs. The output sample rates are selectable via rear panel DIPswitches from one of 32kHz, 44.1kHz, 48kHz, 88.2kHz, 96kHz, 176.4kHz or 192kHz.

The unit has TTL wordclock BNC and AES/EBU XLR synchronising inputs as standard and optionally, the RB-SYA and RB-SYD synchronisation boards can be fitted to synchronise the unit to analogue or digital video signals. A front panel DIPswitch block is used to decide whether the unit is synchronised to Input1, Input2, the AES/EBU sync input, the wordclock sync input or an optional video sync board. A front panel SYNC button selects the synchronisation mode of the unit and the button flashes whenever the unit is not synchronised to an incoming sync signal. Selectable sync modes are as follows:

**Master Mode**

In this mode the digital output sample rate is simply set by, and locked to, the internal on-board clock generator. No sync signal is used or required.

**Auto Sync Mode**

In this mode the digital output sample rate follows the selected sync input. When the sync signal is not present the output sample rate will be set by, and locked to, the internal on-board clock generator at the selected output frequency.

**Auto Lock Mode**

In this mode no output will be generated until lock is achieved with a sync signal. The digital output sample rate now follows the sync input. If the sync signal is removed then the output sample rate will be set by, and locked to, the internal on-board clock generator at the closest frequency available to the previous sync input.

**Slave Mode**

In this mode the digital output sample rate follows the sync input. When the sync signal is not present the digital output is turned off.

The unit can operate in 2 modes - automatic or manual, selectable using a rear panel DIPSwitch. In both modes it will automatically switch over to the auxiliary source on detecting silence. When the main signal is again detected it will either return to the main signal automatically or manually depending on the mode chosen. In manual mode, the front panel RESTORE button is used to return to the main signal.

The RB-DSD1 has a number of remote operational features. Remote outputs provide separate relay contact closures for failure of the main and auxiliary inputs. You can also remotely select between auto and manual mode (with tally output), action the signal RESTORE, set the silence detection delay to be 2mins 5 seconds and define which input is the main input (with tally output). You can remotely start and stop another piece of equipment on

alarm failure and there is an option to set the remote start output as either momentary or latched.

The unit can be configured to alarm when either the left or right channel of the main input source fails, or if the whole stereo signal fails. Additionally, if one channel of a stereo signal is lost, you can define whether to mute the lost channel, or whether to mix the remaining channel to the lost side, effectively creating a mono signal. If the main source synchronisation is lost, you can define whether the unit switches to the auxiliary input in the minimum time (2 seconds), or whether to treat the signal as silence to be detected and then switched based on the unit's silence detection settings.

Front panel LED indicators by the MAIN and AUX buttons show individually left and right programme and alarm conditions for both the main and auxiliary inputs.

A powerful feature of the RB-DSD1 is that by using the Sonifex Sci serial software, the unit can be programmed for different delay durations, levels and switching functions so that you can programme the unit for your specific application. A front panel DIPSwitch configures the unit to be controlled serially and a front panel LED indicates serial operation. Contact Sonifex for further information if you have a particular requirement that isn't catered for by the RB-DSD1 as standard.

The RB-DSD1 has been designed to have a passive signal path through the main input, so if power to the unit fails, signal input 1 is routed to output 1 and signal input 2 is routed to output 2. This is essential for applications such as installation at transmitter sites, where a power failure to the unit should not prevent the audio input signal from being output to the transmitter. Note: This applies to the AES/EBU & S/PDIF I/O, but not the TosLink optical I/O.

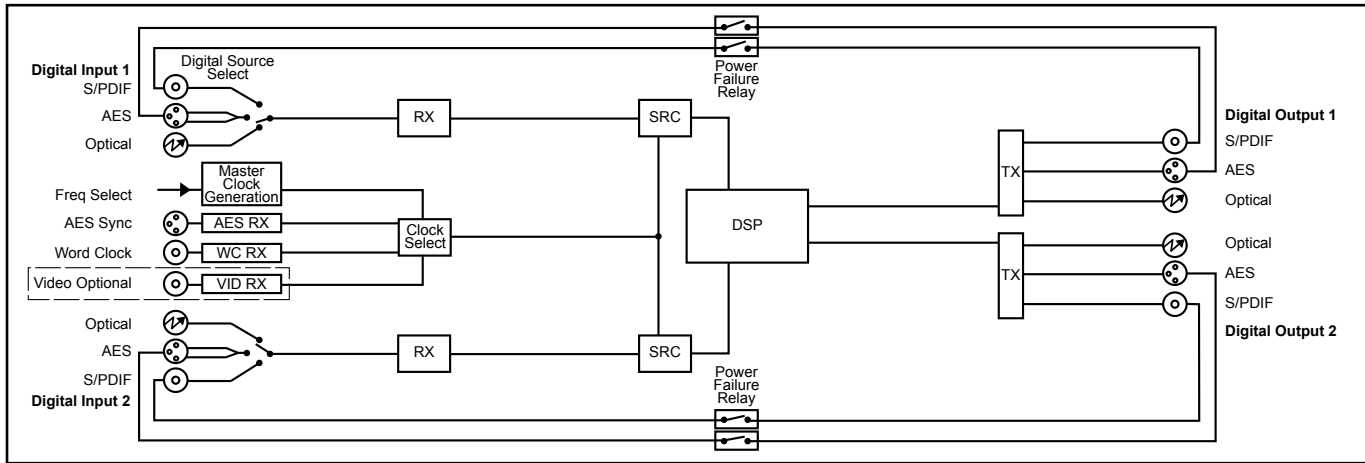

Fig 3-2: RB-DSD1 System Block Diagram

### Front Panel Controls and Indicators

The LED in the front panel is normally red to indicate power to the unit.

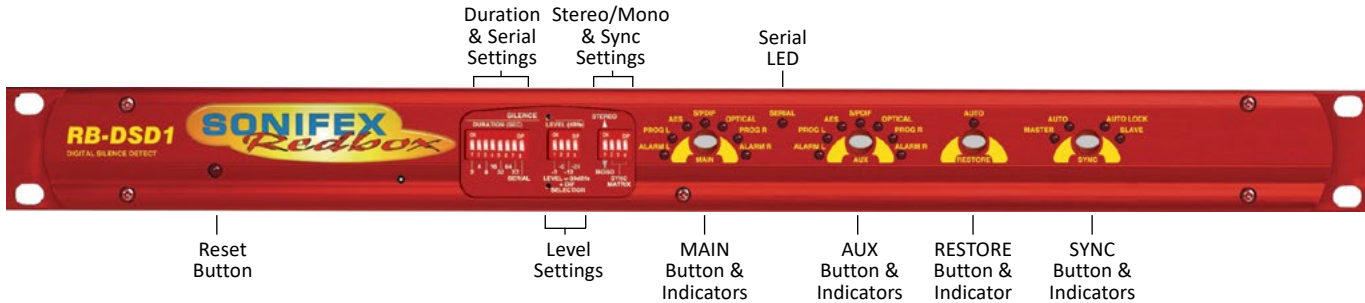

Fig 3-3: RB-DSD1 Front Panel Controls and Indicators

### MAIN Source Select and Indicators

This button allows you to select which input source you would like to use, from one of the AES/EBU, S/PDIF or Toslink inputs. The three LEDs above the button illustrate which source is selected. The button itself will also be illuminated.

Button Colour	Indication
Solid green	Indicating that this is the input that is currently being output
Solid red	Indicating that this input is not selected
Flashing between green and red	Indicating a loss of lock to that input

There are also green and red LEDs, one of each for both left and right channels to show the programme and alarm state of the input. The programme LEDs will be illuminated if the level is above the current silence threshold. If the input is in an alarmed state, the red alarm LEDs will be illuminated.

### AUX Source Select and Indicators

The operation of this button is identical to the above.

### RESTORE Button

The Restore button is used for restoring the main source signal when the unit is operating in Manual Mode. When the main source signal returns after it has timed out, the AUTO LED flashes, indicating that the source signal can be restored. When the Restore button is pressed the main source returns. This can be remotely controlled using pin 7 of the remotes connector.

### SYNC Mode button

This button allows you to cycle through the synchronisation modes. The LEDs around the button display which mode has been selected. If the selected synchronisation source

(see front panel DIPSwitch section for settings) is not locked, the button will flash green and red.

### SERIAL Mode indicator

If serial mode is selected (see front panel DIPSwitch section for settings) this led will be illuminated.

### Reset Button

In the unlikely event that the RB-DSD1 unit fails to respond, press the reset button to reboot the unit (see Fig 10-3 for location).

## Front Panel DIPSwitches

The front panel DIPSwitches are concealed behind the screw panel located on the front of the unit.

### Silence Detect Duration Control

Switch	1	2	3	4	5	6	7
Seconds	2	4	8	16	32	64	X2

The silence detect interval DIPSwitches adjust the duration over which a silence is detected before alarming which ranges from 2-252 seconds (by adding together the raised DIPSwitches, in 2 second intervals). If all the DIPSwitches are down, (off) the duration defaults to 30 seconds. This can be changed using the SCi serial software.

### Serial Mode Setting

To activate serial mode, set DIPSwitch 8 on (up). When activated, the serial mode LED illuminates on the front panel (see Fig 10-3) and the unit can be controlled serially instead of from the front panel controls, using the SCi software.



Fig 3-4: SILENCE Detect Duration DIPSwitch

### Silence Detect Audio Trigger Level

Switch	1	2	3	4
Seconds	-3	-6	-12	-24

The trigger level DIPswitches adjust the level below which silence detection occurs. This level may be varied from -39dBFS to -84dBFS in 3db steps by summing DIPswitches that are on and adding -39dBFS. 0 (all off) represents -39 dBFS.

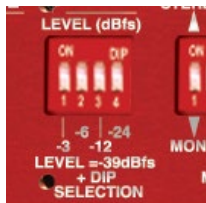

Fig 3-5: SILENCE Detect Audio Trigger Level DIPswitch

### Stereo/Mono Selection

The configuration of this defines whether you want to switch sources when the left and/or right channel of the incoming source go silent.

Switch	Description
On	When on, the unit operates in stereo mode, whereby if one channel goes quiet the unit will switch, and requires both channels to be present before it switches back.
Off	When off, the unit operates in mono mode. In this mode the unit will only switch when both channels go quiet, and requires only one channel to be present before the unit switches back.



Fig 3-6: SILENCE Detect Stereo/Mono & Sync Source DIPswitch

### Synchronisation Source Selection

Select which synchronisation source you would like to use by setting DIPswitches 2 - 4, marked SYNC MATRIX.

Synchronise from	DIPswitch 2	DIPswitch 3	DIPswitch 4
Main input	Off	Off	Off
Aux input	On	Off	Off
AES synchronisation input	Off	On	Off
Wordclock input	On	On	Off
Video sub board	Off	Off	On

### Rear Panel Controls

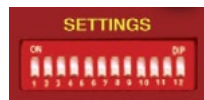

Fig 3-7: Rear Panel DIPswitches

### Output Sample Rate Selection

DIPswitches 1 - 3 allow you to select what sample rate the output will be when the unit is in master mode. Set the DIPswitches where:

Sample Rate (kHz)	DIPswitch 1	DIPswitch 2	DIPswitch 3
32	Off	Off	Off
44.1	On	Off	Off
48	Off	On	Off
88.2	On	On	Off
96	Off	Off	On
176.4	On	Off	On
192	Off	On	On

**Main/Aux Input Selection**

DIPSwitch 4 defines whether the Main input is input 1 or 2.

DIPSwitch 4	Description
<b>On</b>	When on, the Main input is input 2. The Aux input is input 1.
<b>Off</b>	When off, the Main input is input 1. The Aux input is input 2.

**Manual/Auto Mode Selection**

DIPSwitch 5 defines whether the unit is in manual or automatic switch mode.

DIPSwitch 5	Description
<b>On</b>	When on, the unit is automatic mode. The restore LED will be lit in this mode. The unit will switch back to the main input automatically if the control has been switched to aux and the main input level has recovered for 2 seconds.
<b>Off</b>	When off, the unit is in manual mode. The restore LED will begin to flash if the control has been switched to aux and the MAIN level has recovered. The restore button will then switch the unit back to the main input.

**Remote Start Operation**

DIPSwitch 6 defines whether the remote start switch is momentary or latched. Used for starting external equipment when silence is detected.

DIPSwitch 6	Description
<b>On</b>	When on, the remote start pin (pin 15) on the remote connector is pulled low for half a second when the unit switches to the auxiliary input. (Momentary contact).
<b>Off</b>	When off, the remote start pin on the remote connector is pulled low when the unit switches over to the auxiliary input and remains low until the unit switches back to the main source or, if in manual mode, is restored by the user locally or remotely. (Latched contact).

**Operation On Loss Of One Channel**

DIPSwitch 7 defines how the unit reacts to the loss of one channel.

DIPSwitch 7	Description
<b>On</b>	When on, the unit will output the remaining channel to the lost channel to create a dual mono output.
<b>Off</b>	When off, the unit will simply mute the lost channel and continue.

**Operation On Loss Of Lock**

DIPSwitch 8 defines whether the unit treats a loss of lock as a severe event or as a simple loss of level.

DIPSwitch 8	Description
<b>On</b>	When on, the unit will treat the loss of lock condition as severe and the unit will switch to the Aux input after 2 seconds.
<b>Off</b>	When off, the unit will treat the loss of lock no differently to a loss of level.

**Remote Stop Operation**

DIPSwitch 9 defines whether the remote stop is operational. Used for stopping external equipment when the unit recovers from a switched state.

DIPSwitch 9	Description
<b>On</b>	When on and Remote Start is set to momentary, pin 4 will close to pin 11 on the remote connector for half a second. Remote start operation is also affected. If no level is detected on the channel which has been switched to, the remote start pulse will repeat every ten seconds. Please note that the aux alarm will not work in this mode.
<b>Off</b>	When off, the aux alarm operates normally.

**Switching Operation**

DIPSwitch 10 defines whether the unit switches when it loses lock or the level drops, i.e. any failure condition. This is so that the unit can signal a failure without actually switching.

DIPSwitch 10	Description
<b>On</b>	When on, the unit will not switch on any fail condition.
<b>Off</b>	When off, the unit will switch on any fail condition.

**Firmware Mode**

DIPSwitch 12 defines the boot up mode.

DIPSwitch 12	Description
<b>On</b>	When on, the unit boots in bootstrap mode.
<b>Off</b>	When off, the unit boots in 'normal' configuration.

## Remotes Connector

Displayed below are the pin connections and descriptions for the remote connector:

Pin No.	Signal	I/O	Description
Pin 1	Master Alarm Normally Open	O	Relay 1 N/O to Pin 9 in alarm state
Pin 2	Master Alarm Normally Closed	O	Relay 1 N/C to Pin 9 in alarm state
Pin 3	Aux. Alarm Normally Open	O	Relay 2 N/O to Pin 11 in alarm state
Pin 4	Aux. Alarm Normally Closed	O	Relay 2 N/C to Pin 11 in alarm state
Pin 5	Mode Switch	I	Momentary make to Pin 8
Pin 6	Mode Indicator	O	Internal Open Collector to Digital
Pin 7	Restore Switch	I	Momentary make to Pin 8
Pin 8	Digital Ground	-	-
Pin 9	Master Alarm Common	O	N/O to Pin 1, N/C to Pin 2 in alarm state
Pin 10	Max Time Whilst Latched	I	Latched make to Pin 8
Pin 11	Aux. Alarm Common	O	N/O to Pin 3, N/C to Pin 4 in alarm state
Pin 12	+5V	O	To power up to a maximum 100mA
Pin 13	Source Select Indicator	O	Internal Open Collector to Digital Ground
Pin 14	Source Select Switch	I	Momentary make to Pin 8
Pin 15	Remote Start	O	Internal Open Collector to Digital Ground

Pins 1 - 4 are for external use to replicate the alarm conditions for the Main and Auxiliary inputs.

Pins 5 - 7, 13 and 14 are to replicate the switches and indicators for the source select, mode and restore functions.

Pins 8, 9, 11 and 12 are common or voltage pins.

Pin 10 is to select remotely the 2min 5secs silence time. This may be useful for the broadcast of Remembrance Day services, or where you expect a silence of up to 2 minutes to be broadcast. The maximum silence time is set whilst the contact is latched.

Pin 15 is used to remotely start an external piece of equipment and operates on audio fail.

### RS232

The 9-way 'D' type socket connector carries a standard RS232 interface and allows direct connection to a serial port on a PC via a pin-to-pin cable. The pin assignments are as follows:

Pin 2: Transmit data

Pin 3: Receive data

Pin 5: Ground

All other pins are unused.

## RB-DSD1 Inputs & Outputs

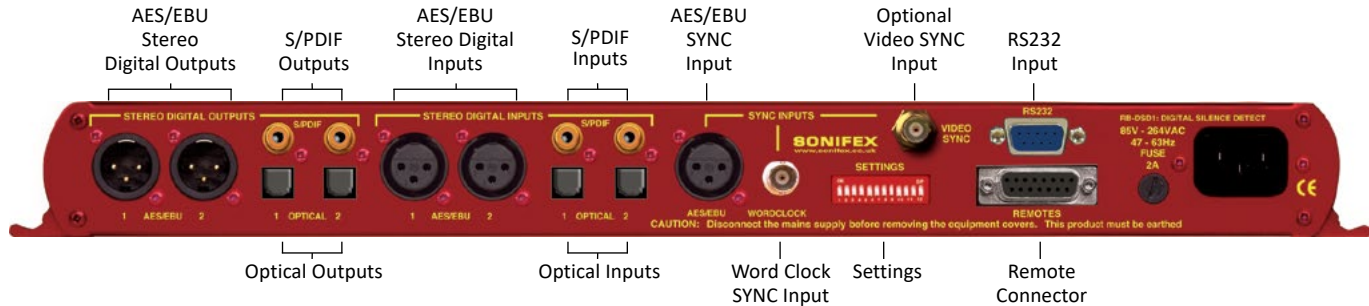

Fig 3-8: RB-DSD1 Rear Panel

### AES/EBU Inputs

The digital input XLR 3 pin socket has an impedance of 110Ω. It has the following connections:

- Pin 1: Screen
- Pin 2: Phase
- Pin 3: Non-phase

The signals on this connector should meet the IEC 60968 specification

### S/PDIF Inputs

The S/PDIF digital phono input have an impedance of 75Ω.

### Optical Inputs

The digital audio optical input meets the TOSLink specification used by most professional & consumer equipment.

### AES/EBU Sync Input

The digital input XLR 3 pin socket has an impedance of 110Ω. It has the following connections:

- Pin 1: Screen
- Pin 2: Phase
- Pin 3: Non-phase

The signals on this connector should meet the IEC 60968 specification

### Word Clock Input

The S/PDIF digital phono input has an impedance of 75Ω.

### AES/EBU Outputs

The digital output XLR 3 pin socket has an impedance of 110Ω. It has the following connections:

- Pin 1: Screen.
- Pin 2: Phase.
- Pin 3: Non-phase.

The signals on this connector comply with the IEC 60968 specification

### S/PDIF Outputs

The digital output S/PDIF phono output has an impedance of 75Ω.

### Optical Outputs

The digital audio optical output meets the TosLink specification used by most professional & consumer equipment.

The outputs have an unweighted dynamic range of at least 138dB and a THD+N noise of or better than -137dB. The data at the outputs are presented as 24 bit wide.

### Serial Port Control

The Serial Port allows the RB-DSD1 to be controlled and updated from a PC via a pin-to-pin serial cable, using the Sonifex Serial Control Interface (SCI) software. This software is available as a free download from the Sonifex website at [www.sonifex.co.uk/sci](http://www.sonifex.co.uk/sci).

#### Default Settings for the Serial Port

Baud Rate:	19200
Data Bits:	8
Stop Bits:	1
Parity:	Even
Handshaking:	XON/XOFF

Fig 3-9: Serial Port Default Settings

### Serial Interface Commands and Responses

Most of the commands follow the same structure: a 3 letter command followed by a colon, followed by a parameter (if any) and terminated by Carriage Return with optional Line Feed. A Line Feed character may be sent but it will be ignored by the RB-DSD1. Commands are not case sensitive.

Responses are CR & LF terminated.

After the RB-DSD1 has been powered-up, an initialisation string is sent "Initialising DSD1".

Following are the commands and the expected responses:

#### Serial Protocol RB-DSD1

Command	Description	Response
AOM:nn	nn represents which channel has been chosen 00 = Manual return 01 = Auto return	-ACK:
Bnn:	Baudrate change where nn is the new baudrate value where: 11 – 115200 57 – 57600 38 – 38400 19 – 19200 96 – 9600	-ACK:
DEL:nnn	Delay length in seconds where nnn is the number of seconds between 2 and 252	-ACK:
DFD:nnn	Default delay length in seconds where nnn is the number of seconds between 2 and 252	-ACK:

Command	Description	Response
DWN:	Initiates a firmware upgrade	-ACK:
FPS:	<p>Front panel and unit status where response is:                      -FPS:aa_bb_cc_dd_ee_ff_gg_hh_iii_jjj_kk_llllll_mmn_nnn                      aa = Input1 source selection                      bb = Input2 source selection                      where 00 = AES, 01 = SPDIF, 02 = TOSLINK                      cc = Sync mode selection                      where 00 = Master, 01 = Auto, 02 = Auto lock, 03 = Slave mode                      dd = Serial flag indication                      where 00: Serial mode off, 01 = Serial mode on                      ee = Frequency                      where 00 = 32k, 01 = 44.1k, 02 = 48k, 03 = 88.2k, 04 = 96k, 05 = 176.4k, 06 = 192k                      ff = Mono/stereo                      where 00 = mono, 01 = stereo                      gg = Sync from                      where 00 = Input 1, 01 = Input 2, 02 = AES sync, 03 = Word clock, 04 = Video sync                      hh = Rear DIPswitch settings                      where hh is a hex value built from the sum of all applicable from:                      01 = Remote stop selected                      02 = No switching                      08 = Input 2 as main source                      10 = Auto mode selected                      20 = Remote start is momentary                      40 = Dual mono on lost channel in stereo mode                      80 = Fail immediately on loss of lock                      iii: Default delay                      jjj: Delay time settings                      where iii and jjj are a value in seconds between 2 and 252                      kk: Remote settings                      where 80 = Pin 10 is actioned on remote port                      llllll: Level settings                      where llllll is a 24 bit hex value defining the current switch level.</p>	

	<p>mmm: Recovery time 1                      where mmm is the current recovery time set for MAIN between 2 and 252 in seconds                      nnn: Recovery time 2                      where nnn is the current recovery time set for AUX between 2 and 252 in seconds</p>	
FRQ:nn	<p>Output framerate selection where                      nn selects which framerate is selected for the output where:                      00 = 32k                      01 = 44.1k                      02 = 48k                      03 = 88.2k                      04 = 96k                      05 = 176.4k                      06 = 192k</p>	-ACK:
IOD:nn	<p>Fail immediately or delay on loss of lock where                      nn selects between the two modes                      00 = Use standard delay on loss of lock                      01 = Fail immediately</p>	-ACK:
LEV:nn	<p>Level settings in dBFS                      nn sets the level of silence between -39 and -84</p>	-ACK:
MIS:nn	<p>Switch which input is represented on the MAIN side where                      nn represents which channel has been chosen                      00 = Main is input 1                      01 = Main is input 2</p>	-ACK:
MOD:nn	<p>Sync mode selection where                      nn selects the synchronization mode where:                      00 = Master mode                      01 = Auto mode                      02 = Auto lock mode                      03 = Slave</p>	-ACK:
MOS:nn	<p>Mono or stereo selection where                      nn selects between the two options where:                      00 = Mono mode                      01 = Stereo mode</p>	-ACK:

Command	Description	Response
NOS:nn	No switch on failure where nn selects between the two options where: 00 = Switch on failure 01 = No switch on failure	-ACK:
OCL:nn	one channel (left or right) lost mode where nn selects between two options where: 00 = Mute the lost channel 01 = Send remaining channel to the other (dual mono)	-ACK:
REM:nm	Remote Control options where n selects which option is being set where: 1 = Remote start mode 2 = Remote stop mode 3 = Remote Restore select m selects the state of the option chosen where: 0 = Option deselected or off 1 = Option selected	-ACK:
RTx:nnn	x sets the channel which is being changed where: 1 = MAIN 2 = AUX nnn sets the amount of seconds it takes for the channel to recover in seconds	-ACK:
SPM:nm	Special mode selection where n selects which modes is being selected where: 1 = signal detection mode 2 = Force main mode 3 = Emergency program override 4 = Detection enabled/disabled mode m selects the state of the option chosen where: 0 = Mode turned off 1 = Mode selected	-ACK:

SRQ: Status Request where-SRQ:aa\_bb\_cc\_dd\_ee\_fg\_hhhh\_ii  
 aa = Input1 lock status  
 bb = Input2 lock status  
 where 00 = unlocked and 01 = locked  
 cc = Restore flash  
 dd = Sync flash  
 where 00 = Not flashing and 01 = flashing  
 ee = Output switched  
 where 00 = Switched and 01 = Not switched  
 fg:  
 f = alarm status and g = program level status  
 where f and g are hex values built from the sum of:  
 1 = Input 1 L  
 2 = Input 1 R  
 4 = Input 2 L  
 8 = Input 2 R

For example if input 1 was in a good state but input 2 was alarmed the value would be C3  
 Alarm status = Input 2L + Input 2R = 4+8 = C  
 Program level status = Input 1L + Input 1R = 1+2=3  
 hhhh: Remote port status  
 where hhhh represents hex values built from the sum of:  
 01: Main alarm  
 02: Aux alarm\remote stop indicator  
 04: Auto indicator  
 08: Remote start indicator  
 10: Source indicator

Follow above example for further clarification  
 ii: Current special mode  
 where ii is a hex value based on which mode is selected:  
 00: No special mode  
 01: Signal detection mode  
 02: Force main mode  
 04: Emergency override mode  
 08: Detection enabled/disabled mode

Command	Description	Response
SSx:nn	Source select where x selects which input is being changed where: 1 = MAIN 2 = AUX nn selects which source is used for that particular input where: 00 = AES 01 = SPDIF 02 = Optical	-ACK:
SYS:nn	Sync source select where nn selects which sync source is used where: 00 = Input 1 01 = Input 2 02 = AES 03 = Wordlock 04 = Video	-ACK:
UID:	Unit id where	-UID:RB-DSD1
VER:	Version number where -VER:x.xxx,y.yyy Where x.xxx is the firmware version and y.yyy id the front panel firmware version number	

**Error Messages**

The following error messages can be returned for illegal commands

- Err:01 = Return if command not found
- Err:02 = Return if missing parameter
- Err:04 = Return if parameter out of range

## SCi for RB-DSD1

The free of charge Sonifex SCi software allows the user to control the RB-DSD1 remotely. The interface has three tabs including a unit setup page, an indication page and a miscellaneous options page. The status of the connection, serial number and firmware versions are always visible at the bottom of the screen.

**Please note:** In order to edit the options on the Unit Setup and Miscellaneous pages, the RB-DSD1 must have the front panel SERIAL mode DIPSwitch set to on (DIPSwitch 8, see page 40).

### Indication Page

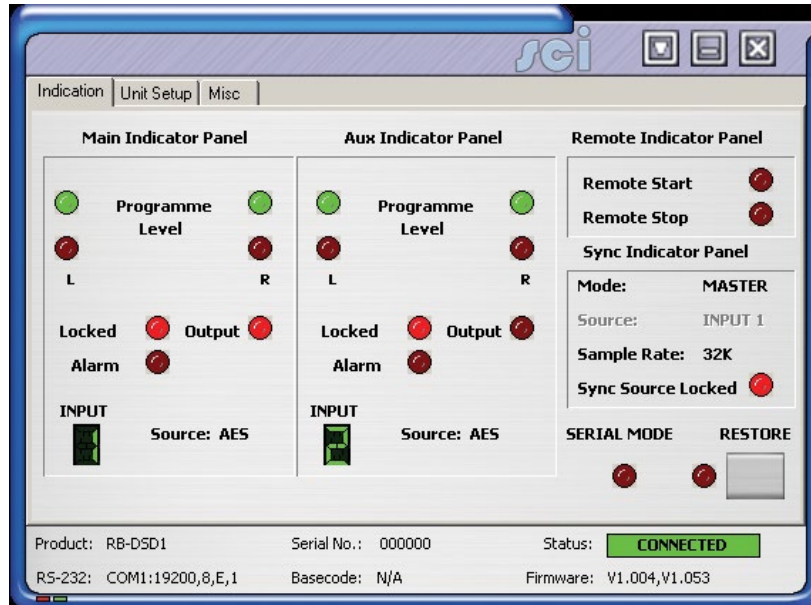

Fig 3-10: Indication Page

This page displays the current status of the unit. Each channel (Main and Aux) has an indicator panel which displays:

**Program Level:** The current audio status is displayed as it is on the front panel.

**Locked LED:** If the input is locked, this LED will be lit.

**Alarm LED:** If the input is alarmed, this LED will be lit.

**Output LED:** If the input is being used as the current output, this LED will be lit.

**Input Segment Display:** The number in this box indicates which input is currently being used for this channel's input.

**Source Label:** The source which is currently being used is displayed here.

**Remote Start & Stop:** The remote start and remote stop signals are displayed in the remote indicator panel. When either of these signals is active, the relevant led will be lit.

Synchronization options are displayed in the sync indicator panel:

**Mode:** This displays the selected sync mode.

**Source:** This displays the selected sync source. This is disabled in Master mode.

**Sample Rate:** This displays the current output sample rate.

**Sync Source Locked LED:** If the synchronization source is locked this LED will be lit.

**Restore:** The Restore button can be used to complete the restore function if the unit is in manual mode. The LED (to

the left of the button) will flash if the unit is ready to be restored. If the LED is lit continuously, the unit is in auto mode.

**Serial Mode:** The serial mode LED indicates whether the unit is in serial mode.

## Unit Setup Page

The screenshot shows the 'Unit Setup Page' for the RB-DSD1 device. The page is organized into four main sections:

- 1. Select Input Sources:** 'Main is' and 'Aux is' are both set to 'AES'.
- 2. Select Synchronisation Options:** 'Sync mode is' is set to 'MASTER' and 'where sample rate is' is set to '32K'.
- 3. Select Trigger and Switch Time Options:** 'Trigger level is minus' is 39 dBFS, 'Switch time is' is 2 seconds, 'Recovery time is' is 2 seconds for main and 2 seconds for aux. There are checkboxes for 'Turn off switching' and 'Fail (2 seconds) on loss of lock', both of which are currently unchecked.
- 4. Select Operational Modes:** 'Main is' is set to 'INPUT 1', 'The unit will return' is set to 'MANUALLY'. There are checkboxes for 'Stereo switching required', 'Dual mono on loss of one channel', 'Remote start is momentary', and 'Remote stop required', all of which are currently unchecked.

At the bottom, the status bar displays: Product: RB-DSD1, Serial No.: 000000, Status: **CONNECTED**, RS-232: COM1:19200,8,E,1, Basecode: N/A, Firmware: V1.004,V1.053.

Fig 3-11: Unit Setup Page

The control page is where you can configure your unit. For ease of use, the options have been split into four sections:

### 1. Select Input Sources

Select which source you would like to use for both the Main Input and the Aux Input from the drop down boxes labeled “Main is” and “Aux is” respectively.

### 2. Select Synchronization Options

Select which sync mode to use from the first drop down box, labeled “Sync Mode is”. If “MASTER” is chosen, then simply select your output sample rate from the drop down box labeled “where sample rate is”. If “AUTO”, “AUTOLOCK” or “SLAVE” are selected, then a new drop down box labeled “From” will appear which allows the user to select the synchronization source.

### 3. Select Trigger And Switch Time Options

Select the trigger level in the first box by typing a value in the box labeled “Trigger level is minus” and pressing return to confirm. The highest value you can enter is 39 and the lowest is 84. Please remember that the value entered is actually a negative value.

The switch time (the time it takes for a low level channel to be registered as a failure and consequently switched to Aux) is determined by the value in the box labeled “Switch time is”. Again, type a value in the box and press return to confirm it. “2” is the minimum value accepted, “252” is the maximum.

**Please note** that if the unit is not in Serial Mode and all front panel time switches are off, you can set the default delay by typing in the desired value between 2 - 252 in the ‘Switch Time is’ box and press return.

The Recovery time (the time needed for a level to be confirmed as good after an alarm state) can be set in the

box labeled “Recovery time is” for the main input and the box labeled “and” for Aux.

There are two tick options that can be selected. Click on the check box to select the option:

- Turn off switching
- Fail (2 seconds) on loss of lock

#### 4. Select Operational Modes

Select which input is the main input by using the drop down box labeled “Main is”.

Select how the unit will return from failure by using the drop down box labeled “The Unit Will Return”.

There are four tick options that can be selected. Click on the check box to select the option:

- Stereo switching required
- Dual mono on loss of one channel - Dual mono the output when the left or right channel is lost in stereo switch mode
- Remote start is momentary, rather than latched
- Remote stop required - If remote start is momentary, then remote stop can be selected.

### Miscellaneous Page

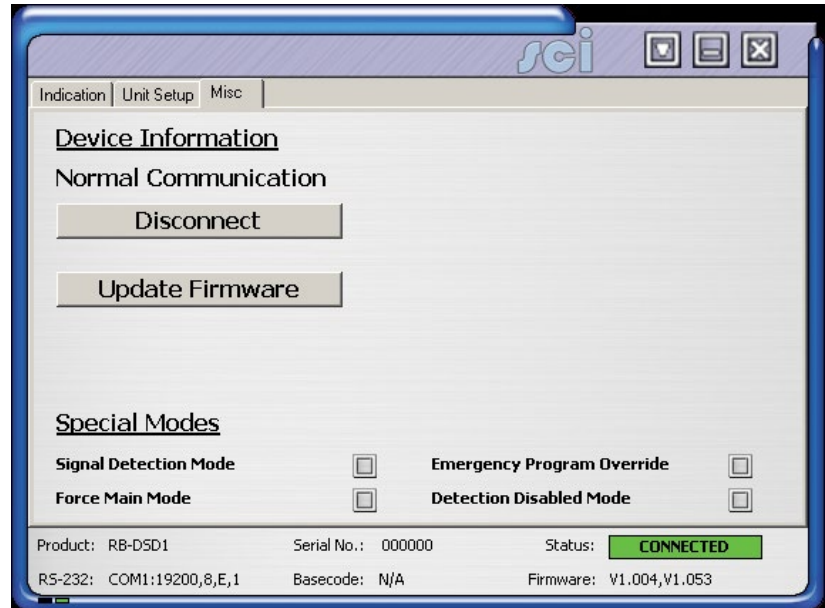

Fig 3-12: Miscellaneous Page

This page is used for the connecting and disconnecting SCi to the unit and for updating the firmware. The Special Modes are also selected from here.

#### Updating The Firmware

The RB-DSD1 firmware will at times be updated to add new features, or to correct any possible issues that may arise. Check for updates at:

<http://www.sonifex.co.uk/technical/software/>

To update the firmware click on the button labeled “Update Firmware” and then select the downloaded firmware file. Firmware files for the RB-DSD1 always have an “.dwn” extension. A progress bar will appear in SCi, indicating how much of the file has been uploaded to the unit.

When the unit switches to update mode, the front panel display leds will all be extinguished. The left program LED is then used to display the status of the upload:

**Uploading the Code:** The LED will begin to flash amber to confirm the unit is receiving the new firmware to RAM.

**Copying Code To Flash Memory:** The LED will be solid amber while the unit checks the integrity of the file and copies the file from RAM to flash memory.

**Successful Update:** The LED will turn green for two seconds and the unit will automatically reset and begin running the new code.

**Unsuccessful Update:** The led will turn red for two seconds and the unit will return to running the last code used.

## Special Modes

### Signal Detection Mode

In this mode the three remote buttons are disabled (mode, source and restore). The recovery time is automatically set to zero for both channels. All other functions operate as in normal mode.

### Force Main Mode

In this mode only the remote mode control input has any effect. When this control input is active (low) the output is forced to Input 2 (MAIN input) regardless of whether audio is present. The unit operates in auto mode and with input 2 as the MAIN input. All other functions operate as in normal mode.

### Emergency Program Override Mode

In this mode all alarm LEDs are illuminated whenever the main input is active. This is to indicate that the emergency paging program is active on the MAIN input. When the paging program goes silent, the unit will revert back to the AUX input and all the alarm LEDs will switch off. All other functions operate as in normal mode.

### Detection Disable/Enable Mode

In this mode the silence detection can be disabled and enabled remotely. The SCi “Detection is” drop down box and the remote source button is used to switch between the two modes. The “Detection is” drop down box toggles the state, while the remote source control (pin 14 on the remote connector) can only ENABLE the silence detection feature. Pin 10 on the remote connector is used to DISABLE silence detection. When the unit powers up Silence Detection is always enabled. The remote source select indicator (Pin 13 on the remote connector) is enabled when Silence Detection is disabled. In this mode Input 1 is always the MAIN input and Input 2 is always the AUX input. The AUX alarms are masked for both front panel indicators and remote alarm relay, for as long as the MAIN input is present.

When Special Modes are selected, certain controls are disabled or altered:

**Signal Detection Mode:** Main Input and return mode selection is disabled. Recovery times are set to zero.

**Force Main Mode:** Main Input and return mode selection is disabled.

**Emergency Program Override Mode:** Main Input selection is disabled.

**Detection Enabled/Disabled Mode:** The Main Input selection label becomes “Detection Is” and the options available change to “ENABLED” and “DISABLED”.

## Technical Specification For RB-DSD1

### Audio Specification

Dynamic Range:	>138dB
Distortion and Noise:	<-137dB THD + N at 1kHz, ref 0dB FS
Input & Output Impedances:	110Ω ±20% AES/EBU balanced I/O 75Ω ±5% S/PDIF unbalanced I/O 75Ω ±5% Toslink unbalanced I/O 50Ω BNC TTL word clock input
Signal Level:	Balanced: 3V/10V peak to peak min/max Unbalanced: Min 0.5V±20% peak to peak
Sample Frequencies:	32, 44.1, 48, 88.2, 96, 176.4 or 192kHz
Bit Depth:	Up to and including 24 bit

### Front Panel Operational Controls & Indicators

Digital Input Select:	AES/EBU, S/PDIF or Toslink optical via INPUT 1 or INPUT 2 push-buttons
Sync Input Select:	AES/EBU, wordclock, INPUT 1, INPUT 2 or video board, via front panel DIPSwitch
Sync Mode Select:	Master, slave, auto or auto lock, via SYNC push-button
Alarm Threshold:	-39dBfs to -84dBfs in 3dBfs steps via front panel DIPSwitches
Silence Detect Duration:	0 - 252 seconds in 2 second intervals via front panel DIPSwitches
Detection Type:	Mono or stereo, via front panel DIPSwitch
Restore Control:	Manual restore button & mode indication LED
Indicators:	Program and alarm indicators for left and right sources for both main and auxiliary inputs

### Rear Panel Operational Controls

Master Frequency Select:	32, 44.1, 48, 88.2, 96, 176.4 or 192kHz via rear panel DIPSwitches
Input Select:	Main input from INPUT 1 or INPUT 2 via DIPSwitch
Restore Mode:	Automatic or manual, via DIPSwitch
Remote Start:	Latched or momentary, via DIPSwitch
Channel Loss:	Mute channel or mix remaining, via DIPSwitch
Sync Loss:	Switch immediately or treat as silence delay, via DIPSwitch

### Connections

Digital Inputs:	2 x AES/EBU XLR 3 pin female 2 x S/PDIF RCA phono 2 x TosLink optical input
Digital Outputs:	2 x AES/EBU XLR 3 pin plug 2 x S/PDIF RCA phono socket 2 x TosLink optical output
Sync Inputs:	1 x AES/EBU XLR 3 pin female 1 x Word Clock BNC 1 x Video Input (optional)
Remote I/O Port:	15 way D-type plug
Serial Port:	RS232, RJ45 socket
Mains Input:	Universal filtered IEC, continuously rated 85-264VAC @47- 63Hz, max 10W
Fuse Rating:	Anti-surge fuse 1A 20 x 5mm

### Equipment Type

RB-DSD1:	Digital silence detection unit
----------	--------------------------------

#### Physical Specifications

Dimensions (Raw): 48cm (W) x 10.8cm (D\*) x 4.2cm (H) (1U)  
19" (W) x 4.3" (D\*) x 1.7" (H) (1U)

Dimensions (Boxed): 59cm (W) x 27.5cm (D) x 11cm (H)  
23.2" (W) x 10.8" (D) x 4.3" (H)

Weight: Nett: 1.4kg Gross: 2.0kg  
Nett: 3.1lb Gross: 4.4lb

#### Accessories

RB-SYA: Analogue video sync board (NTSC, PAL & SECAM)

RB-SYD: Digital video sync board (SD-SDI & HD-SDI)

RB-RK3: 1U Rear panel rack kit for large Redboxes

\* **Note** that this product is deeper than standard Redboxes

## 4 RB-DSD8 8 Channel Silence Switcher



Fig 4-1: RB-DSD8 Front Panel

The RB-DSD8 8 provides silence detection over 8 channels of audio, organised as 4 pairs. The pairs can be either analogue or digital and can be used independently to act as 4 independent silence detectors or they can be linked to switch simultaneously. The unit is designed to switch from the main input to the backup input in the event of loss of audio.

The unit can switch:

- Automatically when the main input level is below the set switching level
- Automatically when the digital input becomes unlocked.
- Manually by front panel or remote control button press.
- Manually by webservice or serial interface.

The audio inputs can be analogue or digital, with ADCs incorporated into the input paths. The input path switches based on digital lock, allowing for automatic input selection. The output is also selectable as analogue or digital. This is achieved by a DAC in the output path and can be switched in manually by rear panel DIPswitches. The unit switch level settings are in dBFS. When using analogue signals, the equivalent full scale value can be set to +24dBu, +18dBu, or +12dBu by rear panel DIPswitches. Since the silence detection feature can be switched off, this means the unit can also be used as an 8 channel AD/DA.

Each pair has individual settings and controls but share settings once they are linked. The foremost pair determines the switching characteristics and controls to be used. Each stereo pair has an AES LED that shows the status of the digital audio on that channel and a selection LED to show which input is currently being sent to each output. Two presence LEDs, one for each mono input of each pair, indicate the current input level.

The unit can switch between sources automatically or manually at the push of a button. If switching manually, silence detection is disabled and the user chooses when to switch using the main or backup buttons. If switching automatically, the unit will switch between the two sources automatically upon the detection of silence. Each pair can be set to switch manually or automatically and the current setting is indicated by the mode LED. The unit can also return back to the main input manually or automatically, and the automatic return can be delayed.

Link/Select buttons are used to group channels to access multichannel operation. Each pair has a Link/Select button which illuminates blue when active. Pressing and holding the first Link/Select button with any other Link/Select button causes all inputs up to that point to be selected.

The RB-DSD8 has a slave mode facility that allows you to connect two RB-DSD8 units and control them simultaneously from one unit.

The silence detect level is adjustable between -27dBFS and -84dBFS in 3dBFS steps via DIPSwitches and this level is compared to peak signals. The silence interval can be adjusted between 2 seconds and 252 seconds in 2 second steps via DIPSwitches. The return duration can also be adjusted between 2 seconds and 252 seconds.

A powerful feature of the RB-DSD8 is that by using the in-built web server or Sonifex SCI serial software, the unit can be programmed for different delay durations, levels and switching functions so that the unit can be set up the unit for any specific application. Set a DIPSwitch to configure the unit to be controlled serially or via web server, this is indicated by a front panel LED. Now you can connect to the unit using either USB or Ethernet. Contact Sonifex for further information if you have a particular requirement that isn't catered for by the RB-DSD8 as standard.

The RB-DSD8 has been designed with dual redundant power supplies. This means that if either power supply fails, the other is ready to take over. In the extremely unlikely event that both fail, the unit has been designed with a passive signal path through the main input. This is essential for applications such as installation at transmitter sites, where a power failure to the unit should not prevent the audio input signal from being output to the transmitter.

### **Clocking & Synchronisation**

All digital input signals are routed to a sample rate converter allowing mixed incoming sample rates to be used. The output sample rates are selectable via DIPSwitches from a predefined master clock of 32kHz, 44.1kHz, 48kHz, 88.2kHz, 96kHz, 176.4kHz or 192kHz or the clock can be derived from a synchronisation input. When analogue inputs are selected, the analogue to digital converters are also clocked at that sample rate.

DIPSwitches can be used to choose the synchronisation mode and the synchronisation source from TTL wordclock or AES/EBU through the dual-purpose synchronising input as standard. A front panel indicator shows the

status of the synchronization input. Selectable synchronisation modes are as follows:

#### **Master Mode**

In this mode the digital output sample rate is simply set by, and locked to, the internal on-board clock generator. No synchronisation signal is used or required.

#### **Auto Lock Mode**

In this mode the digital output sample rate will follow the synchronisation input. If the synchronisation signal is removed then the output sample rate will be set by, and locked to, the internal on-board clock generator at the closest frequency available to the previous synchronisation input.

#### **Slave Mode**

In this mode the digital output sample rate follows the synchronisation input. When the synchronisation signal is not present the digital output is turned off.

## Front Panel Controls & Indicators



Fig 4-2: RB-DSD8 Status Buttons

### Status Buttons

#### AUTO Button

This button is used to select automatic mode for all channels that are selected using the Link/Select buttons. This button deactivates MANUAL and SLAVE mode and illuminates green when selected. Press and hold the button for two seconds to activate this mode. This mode can only be selected from one of the other modes if the main signal is present and above the threshold level. The button and the associated mode LED will flash to indicate these conditions have been met. To restore to main from backup in automatic mode push and hold the button for two seconds. This selection is the default for all channels. When in AUTO mode, the switch back can also be automatically controlled. This is set using the ASB Command in the serial protocol or 'Automatic Switch Back' option on the webserver's general settings page.

#### MANUAL Button

This button is used to select manual mode for all channels that are currently selected. This button illuminates red when selected and deactivates the AUTO and SLAVE mode. Press and hold the button for two seconds to select this mode. The MAIN and BACKUP buttons can then be used to control which channel is selected.

#### SLAVE Button

This button is used to select the unit as slave controlled and is illuminated

yellow. Pressing this button disables both the MANUAL button and the AUTO button. Press and hold this button for two seconds to select this mode. Please note that SLAVE selection is applied across the whole unit. All channels will revert to which ever mode is used to deactivate the SLAVE mode.

#### MAIN Button

This button selects the main input as the output for the currently selected channels. The button illuminates green if MAIN input is selected. This selection is the default for all channels. Press and hold the button for 2 seconds to select the MAIN source. Please note that pressing and holding this button at any time will select MANUAL mode.

#### BACKUP Button

This button selects the backup input as the output for the currently selected channels. Press and hold the button for 2 seconds to select the BACKUP source. The button illuminates red if BACKUP input is selected. Please note that pressing and holding this button at any time will select MANUAL mode.

### DISPLAY LEDS



Fig 4-3: RB-DSD8 Controls & Indicators For Each Channel

#### Presence LEDs 1(L) 2(R)

Each stereo input channel has an associated Presence LED which indicates

the level of that channel. Each LED has three states:

- Green – This indicates that the level on that channel is above threshold
- Yellow – This indicates that the level on that channel is below threshold
- Red – This indicates that the channel is silent i.e. no audio at all

#### AES LEDs

Each channel pair has an AES LED associated. This LED indicates the status of the digital audio. Each LED has four states:

- Green – AES detected and everything is fine. The input sample rate matches the output sample rate.
- Yellow – AES detected and everything is fine. The input sample rate is different to the output sample rate.
- Red – AES detected but an error has been detected.
- Off – No digital signal is present or the analogue input is being used.

The following errors can create a red state:

- CRC error
- Parity error
- Validity bit error
- Biphase encoding error.

#### SEL LEDs

Each channel pair has a SElection LED associated with each stereo MAIN and BACKUP input. This LED indicates which input is currently being used for the output. The MAIN selection LED illuminates green when the associated output is from the MAIN input. The BACKUP selection LED illuminates red when the associated output is from the BACKUP input. Only one of these two LEDs can be on for any one channel at any given time.

#### MODE LEDs

Each stereo pair of MAIN and BACKUP inputs has a MODE LED which

indicates which switching mode is currently being employed on that channel. The MODE LED has three states:

- Green – The channel is in AUTO mode
- Yellow – The channel is in SLAVE mode
- Red – The channel is in MANUAL mode

#### LINK/SELECT Buttons & LINK LED

There are four LINK/SELECT buttons, one for each channel pair. To link any inputs simply press and hold the link buttons for 2 channels. All channels between the selected channels will be included in the link. Once linked, the yellow link LED between them will illuminate. For example, to link channels 1 & 2, 3 & 4 and 5 & 6, press and hold the link buttons on channels 1 & 2 and 5 & 6 for 2 seconds. Whilst channels 1 & 2 and 3 & 4 are linked, there is an additional option to link 5 & 6 and 7 & 8 together individually. To do this press and hold LINK/SELECT 5 & 6 and 7 & 8 for 2 seconds. To release this mode, press and hold either LINK/SELECT 5 & 6 or LINK/SELECT 1 & 2. The left-most channel pair (usually channels 1 & 2) will dominate and all other pairs will inherit their settings, with the new settings being reflected by changes to the status indicators.



## Additional Indicators



Fig 4-4: RB-DSD8 Additional Indicators

### EXT SYNC LED

This LED displays the synchronisation mode that is currently selected. This LED has five states:

- Green – Master mode is selected
- Yellow – Slave mode is selected
- Flashing yellow – Slave mode selected but synchronisation is lost
- Red – Auto mode is selected
- Flashing red – Auto mode selected but synchronisation is lost.

### Remote Control Indicator

If remote control mode is selected (see DIPSwitch section for settings) this LED will be illuminated.

### PSU (Power Supply) Indicators

Each PSU on the unit has its own indication LED. If both PSUs are working and correct both LEDs are illuminated green. If the internal ADC circuitry detects the level drop below a sufficient level on a particular supply, its representative LED will illuminate red instead to indicate a fault.

### Reset Button

In the unlikely event that the RB-DSD8 unit fails to respond, press the reset button to reboot the unit (see Fig 1-1 for location).

### Reset to Default Settings Using the Reset Button

Press reset and wait for all of the front panel LEDs to illuminate. When they turn off, a 5 second counter begins. Reset the unit within these five seconds to increment the reset tally. Repeat process again to reset to defaults. If the counter ever elapses, the reset tally will return to zero and the whole process will need to start again.

## Rear Panel DIPSwitch Settings



Fig 4-5: RB-DSD8 Rear Panel DIPSwitches

### Rear Panel DIPSwitches: Bank 1 SILENCE LEVEL AND DURATION

#### Silence Detect Interval Control (DIPSwitches 1-7, Bank 1)

DIPSwitch	1	2	3	4	5	6	7
Seconds	2	4	8	16	32	64	128

The silence detect interval DIPSwitches adjust the duration over which a silence is detected before alarming and ranges from 2-254 seconds by combining raised (ON) DIPSwitches in 2 second intervals with 0 being all DIPSwitches down. The default value is set at 30 seconds but can be changed using the serial port or ethernet. This time can also be overridden by a remote GPI/O input that sets the unit to an override time that is set to 2mins 5 seconds.

#### Silence Detect Trigger Level (DIPSwitches 8-11, Bank 1)

DIPSwitch	8	9	10	11
Level dBFS	-3	-6	-12	-24

The trigger level DIPSwitches adjust the level below which silence detection occurs. This level may be varied from -27dBFS to -84dBFS in 3db steps

by raising different combinations (to ON). Please note the range changes depending on the full scale settings. These represent -15dBu to -60 dBu

Full Scale	Min	Max
12dBu	-27dBFS	-72dBFS
18dBu	-33dBFS	-78dBFS
24dBu	-39dBFS	-84dBFS

### Stereo/Mono Switch (DIPSwitch 12, Bank 1)

The configuration of this defines whether you want to switch sources when left and/or right channel of the incoming source go silent. When channels are linked the stereo mode becomes multichannel mode and any single mono channel failure will cause the unit to switch sources; likewise mono mode will require both channels to fail individually before switching sources.

DIPSwitch 12	Description
On	When on, the unit operates in mono mode. In this mode the unit will only switch when both channels go quiet, and requires only one channel to be present before the unit switches back.
Off	When off, the unit operates in stereo mode, whereby if one channel goes quiet the unit will switch, and requires both channels to be present before it switches back.

### Rear Panel DIPSwitches: Bank 2 DIGITAL AUDIO SETTINGS

#### Master Mode Frequency Selection (DIPSwitches 1-3, Bank 2)

These DIPSwitches allow you select what sample rate the output will be when the unit is in master mode.

Sample Rate (kHz)	DIPSwitch 1	DIPSwitch 2	DIPSwitch 3
32	Off	Off	Off
44.1	On	Off	Off
48	Off	On	Off
88.2	On	On	Off
96	Off	Off	On
176.4	On	Off	On
192	Off	On	On

#### External Synchronisation Source (DIPSwitch 4, Bank 2)

Select which synchronisation source you would like to use by setting this DIPSwitch:

DIPSwitch 4	Synchronise From
On	Wordclock/AESEBU synchronisation input
Off	Main Input Pair 1

**Note:** This DIPSwitch is redundant when running in synchronisation master mode.

#### Synchronisation Mode Selection (DIPSwitches 5-6, Bank 2)

These DIPSwitches allow you select which synchronisation mode the unit is in.

DIPSwitch 5	DIPSwitch 6	Synchronisation Mode
Off	Off	Master Mode
On	Off	Auto Mode
Off	On	Slave Mode
On	On	Reserved

#### Remote Start Mode Switch (DIPSwitch 7, Bank 2)

This defines whether the remote start switch is momentary or latched. Used for starting external equipment when silence is detected on channel 1. The channel can be reassigned through the serial port.

DIPSwitch	Description
On	When off, the remote start pin on the remote connector is pulled low when the unit switches over to the backup input and remains low until the unit switches back to the main source or, if in manual mode, is restored by the user locally or remotely. (Latched contact).
Off	When on, the remote start pin (pin 7) on the remote connector is pulled low for half a second when the unit switches to the Backup input. (Momentary contact). If the level detected on the backup channel is below the switch threshold, the remote start will continue to pulse every 10 seconds until a valid signal is detected.

#### Loss of Lock Failure (DIPSwitch 8, Bank 2)

This defines whether the unit treats a loss of synchronisation lock as an immediate switch event or as a simple loss of level.

**Note:** Switch this to 'Off' when using an analogue input.

DIPSwitch 8	Description
On	When on, the unit treats the loss of lock condition as an immediate switch event. The unit switches immediately to the Backup input.
Off	When off, the unit treats the loss of lock no differently to a loss of level.

**Output Pair Configuration (DIPSwitches 9-12, Bank 2)**

These DIPSwitches allow you select whether each output pair is analogue or digital. Set each DIPSwitch so that:

DIPSwitch 9 - 12	Description
On	When on, the pair outputs a balanced analogue signal.
Off	When off, the pair outputs an AES/EBU digital signal.

DIPSwitch 9 = Channel Pair 1 & 2

DIPSwitch 10 = Channel Pair 3 & 4

DIPSwitch 11 = Channel Pair 5 & 6

DIPSwitch 12 = Channel Pair 7 & 8

**Rear Panel DIPSwitches: Bank 3 MISC SETTINGS****Ignore Silence Settings (DIPSwitches 1-8, Bank 3)**

Each channel has a DIPSwitch to determine whether it is ignored when AUTO silence switching.

DIPSwitch 1 - 8	Description
On	When on, the channel is ignored.
Off	When off, the channel is silence detected.

DIPSwitch 1 = Channel 1

DIPSwitch 2 = Channel 2

DIPSwitch 3 = Channel 3

DIPSwitch 4 = Channel 4

DIPSwitch 5 = Channel 5

DIPSwitch 6 = Channel 6

DIPSwitch 7 = Channel 7

DIPSwitch 8 = Channel 8

**Remote Control Enable (DIPSwitch 9, Bank 3)**

This DIPSwitch enables serial/ethernet settings which are determined by the Sonifex SCI software.

DIPSwitch 9	Description
On	When on, the unit uses the serial/ethernet settings.
Off	When off, the unit uses on board/front panel settings.

**Full Scale Line Up (DIPSwitches 10-11, Bank 3)**

These DIPSwitches allow you set up the full scale line up of the ADCs and DACs.

**Note:** These settings affect the silence level setting.

The settings are as follows:

DIPSwitch 10	DIPSwitch 11	Synchronisation Mode
Off	Off	0 dBFS = 24 dBu
On	Off	0 dBFS = 18 dBu
Off	On	0 dBFS = 12 dBu
On	On	Reserved

**Boot Mode (DIPSwitch 12, Bank 3)**

This DIPSwitch forces the unit into boot mode. The firmware can be updated from here in the unlikely event that the firmware becomes corrupted.

**Note:** Firmware uploads can only be done via the serial port in boot mode.

Switch	Description
On	When on, the unit powers up and boots into boot mode.
Off	When off, the unit powers up and boots normally.

## RB-DSD8 Rear Panel Connections

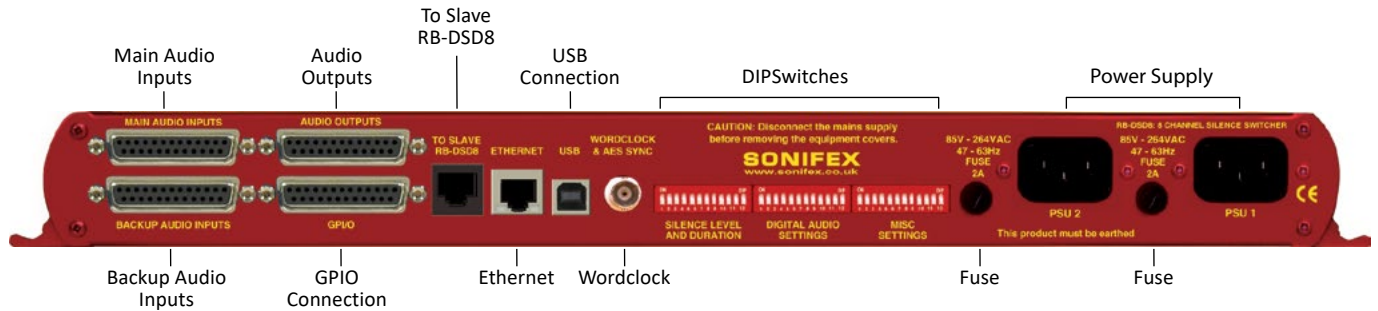

Fig 4-6: RB-DSD8 Rear Panel

## Audio Connections

There are 4 x 25-pin female D-type connectors which provide the audio inputs/outputs and the general purpose inputs/outputs (GPIO).



Fig 4-7: Audio & GPIO Connector Detail

The leftmost two D-types provide for the simultaneous connection of up to four stereo, (eight mono) analogue or digital audio inputs for both Main and Backup sources. The rightmost two D-types provide eight stereo analogue or digital outputs and the Remote GPI/Os, 9 inputs and 14 outputs. The pin assignments are as follows:

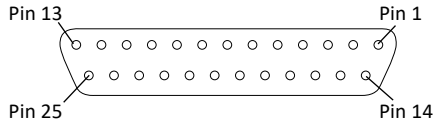

Fig 4-8: Audio Connector Pin Numbers

Connector Pin Number	Audio Inputs	Audio Outputs
1	Analogue Input 1 L+ or Digital Input 1+	Analogue Output 1 L+ or Digital Output 1+
14	Analogue Input 1 L- or Digital Input 1-	Analogue Output 1 L- or Digital Output 1-
2	Analogue Input 1 Ground or Digital Input 1 Ground	Analogue Output 1 Ground or Digital Output 1 Ground
15	Analogue Input 1 R+	Analogue Output 1 R+
3	Analogue Input 1 R-	Analogue Output 1 R-
16	Analogue Input 1 L Ground	Analogue Output 1 L Ground
4	Analogue Input 2 L+ or Digital Input 2+	Analogue Output 2 L+ or Digital Output 2+
17	Analogue Input 2 L- or Digital Input 2-	Analogue Output 2 L- or Digital Output 2-
5	Analogue Input 2 R Ground or Digital Input 2 Ground	Analogue Output 2 R Ground or Digital Output 2 Ground
18	Analogue Input 2 R+	Analogue Output 2 R+
6	Analogue Input 2 R-	Analogue Output 2 R-
19	Analogue Input 2 R Ground	Analogue Output 2 R Ground
7	Analogue Input 3 L+ or Digital Input 3+	Analogue Output 3 L+ or Digital Output 3+

20	Analogue Input 3 L- or Digital Input 3-	Analogue Output 3 L- or Digital Output 3-
8	Analogue Input 3 L Ground or Digital Input 3 Ground	Analogue Output 3 L Ground or Digital Output 3 Ground
21	Analogue Input 3 R+	Analogue Output 3 R+
9	Analogue Input 3 R-	Analogue Output 3 R-
22	Analogue Input 3 R Ground	Analogue Output 3 R Ground
10	Analogue Input 4 L+ or Digital Input 4+	Analogue Output 4 L+ or Digital Output 4+
23	Analogue Input 4 L- or Digital Input 4-	Analogue Output 4 L- or Digital Output 4-
11	Analogue Input 4 L Ground or Digital Input 4 Ground	Analogue Output 4 L Ground or Digital Output 4 Ground
24	Analogue Input 4 R+	Analogue Output 4 R+
12	Analogue Input 4 R-	Analogue Output 4 R-
25	Analogue Input 4 R Ground	Analogue Output 4 R Ground
13	N/C	N/C

Unbalanced signals may also be used by linking the out-of-phase (-) signal pin to Ground and applying the unbalanced signal to the in-phase (+) signal pin. Please remember to terminate all unused inputs. Leaving them unterminated can cause the Presence LEDs to show erroneous states.

### GPI/O Remotes Connector

Displayed below are the pin connections and 1. Introduction

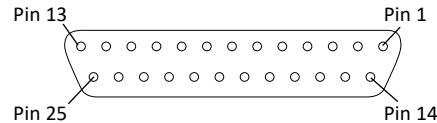

Fig 4-9: GPI/O Remotes Connector Pin Numbers

Pin Number	Signal	I/O	Description
1	Channel 1 & 2 MAIN OK	O	Internal Open Collector to Digital Ground
14	Channel 3 & 4 MAIN OK	O	Internal Open Collector to Digital Ground
2	Channel 5 & 6 MAIN OK	O	Internal Open Collector to Digital Ground
15	Channel 7 & 8 MAIN OK	O	Internal Open Collector to Digital Ground
3	Channel 1 & 2 BACKUP OK	O	Internal Open Collector to Digital Ground
16	Channel 3 & 4 BACKUP OK	O	Internal Open Collector to Digital Ground
4	Channel 5 & 6 BACKUP OK	O	Internal Open Collector to Digital Ground
17	Channel 7 & 8 BACKUP OK	O	Internal Open Collector to Digital Ground
5	Channel 1 & 2 BACKUP SELECTED	O	Internal Open Collector to Digital Ground
18	Channel 3 & 4 BACKUP SELECTED	O	Internal Open Collector to Digital Ground
6	Channel 5 & 6 BACKUP SELECTED	O	Internal Open Collector to Digital Ground
19	Channel 7 & 8 BACKUP SELECTED	O	Internal Open Collector to Digital Ground
7	Remote Start/Audio Fail	O	Internal Open Collector to Digital Ground
20	PSU failure	O	Internal Open Collector to Digital Ground
8	Override Time	I	Diode Protected Input to Microprocessor
21	Select BACKUP channel 1 & 2	I	Diode Protected Input to Microprocessor
9	Select BACKUP channel 3 & 4	I	Diode Protected Input to Microprocessor
22	Select BACKUP channel 5 & 6	I	Diode Protected Input to Microprocessor

10	Select BACKUP channel 7 & 8	I	Diode Protected Input to Microprocessor
23	Select MAIN Channel 1 & 2	I	Diode Protected Input to Microprocessor
11	Select MAIN Channel 3 & 4	I	Diode Protected Input to Microprocessor
24	Select MAIN Channel 5 & 6	I	Diode Protected Input to Microprocessor
12	Select MAIN Channel 7 & 8	I	Diode Protected Input to Microprocessor
25	Digital Ground	DGND	-
13	+5V	PWR	To power up to a maximum 200mA

### Alarm Output Pins

#### Main And Backup Status & Selection Indicators

Pins 1 – 7 & 14 - 20. Each pin sinks current to DGND in the alarm state.

#### Remote Start/Audio Fail Pin

Pin 7 is used to remotely start an external piece of equipment and it operates on audio fail. It can also be set to be momentary or latched using DIPswitch 7 on the second bank of DIPswitches. If set to be momentary in operation and no valid audio is detected, the pin will continue to pulse at 10 second intervals.

### Control Inputs

#### MAIN/AUTO & BACKUP/MANUAL Selection Inputs

Pins 8 – 12 & 21 - 24 are used to trigger a state by applying a 0V to the pin. The pins are diode protected around 3.3V.

If the BACKUP selection pins (9, 10, 21 & 22) are held low for 2 seconds, the BACKUP input for the pair represented by the pin is selected and the pair will be in MANUAL mode. A momentary stimulation will simply select the specific channel pair (equivalent of pushing a LINK/SELECT button on the front panel).

The MAIN selection pins (11, 12, 23 & 24) will behave like the BACKUP pins, unless the unit is in MANUAL mode. In MANUAL mode, the MAIN input will be selected by momentary press.

To return the selected pair to AUTO mode, ensure there is a valid signal on the MAIN input (indicated by a flashing status LED) and then hold both the MAIN and BACKUP for that particular input low for two seconds.

#### Override Time Pin

Pin 8 is to remotely select an override silence time (default is 2min 5sec). This may be useful for the broadcast of Remembrance Day services, or where you expect a silence of up to 2 minutes to be broadcast. The override silence time is set whilst the contact is active, therefore a latching button is recommended. The override time can be changed via the Sonifex SCI software. Pin 13 is a voltage supply pin. 5V is supplied up to a maximum current of 200mA. Pin 25 is a ground reference level.

#### Slave Socket

An 8 way RJ45 connector allows connection to another RB-DSD8 unit, via RS485.

Pin 4: TX/RX -

Pin 5: TX/RX +

Pin 8: DGND

All other pins are unused.



Fig 4-10: Communications Connectors

#### USB Remote Control

A Type B USB socket carries a standard Universal Serial Bus interface via which advanced configuration options may be set and many functions may be remotely controlled.

The RB-DSD8 will interface directly with personal computer USB ports using a standard USB cable. On first connection, you will be prompted to install the necessary USB driver (supplied), following which the USB connection behaves as a “virtual serial port” with identical data format and command protocol as the RS232 remote control interface.

## Ethernet

The 8-way RJ45 socket connector carries a standard Ethernet interface and allows connection to a local area network. The pin assignments are as follows:

Pin 1: Receive data+

Pin 2: Transmit data+

Pin 3: Transmit data+

Pin 6: Receive data-

Pin 5: Ground

All other pins are unused. Please note that the unit uses a 10Mbit connection.

## Wordclock & AES Synchronisation Input

This BNC is used as a digital input and has an impedance of 75Ω. The input is autosensing and can be used to provide an external synchronisation signal from an AES3 source or from a TTL wordclock.

## Dual IEC Main Inputs

The RB-DSD8 has 2 mains inputs for power supply redundancy, which provides protection against a single point of failure on the internal power supply units, and, if distinct sources are used for the mains inputs, it will also protect against a mains input failure. The inputs are rated at 2A and will accept a voltage range of 85V to 264VAC.

## Remote Control

### Slave Control

The RB-DSD8 can be connected to another unit and controlled. This is useful if you want two units to behave in an identical fashion, simultaneously, as both are controlled from one interface. To achieve this, connect two units together with a standard Ethernet cable via the designated slave RJ45 sockets. Once connected, select Slave Mode on the designated slave unit. Please note that only the switching methods are controlled.

### Remote Configuration

The unit can be remotely configured using via serial interface or via ethernet. To use the serial interface, connect the unit to a pc via the USB port and use a standard USB cable. This is “plug and play” and the drivers should self-install, although the drivers are included on the installation CD. The unit can also connect via the Ethernet port using a standard RJ45 Ethernet cable. Both methods connect to the Sonifex Serial Control Interface (SCI) software.

#### Default Settings for the Serial Port

Baud Rate: 115200

Data Bits: 8

Stop Bits: 1

Parity: Even

Handshaking: None

## Serial Interface Commands & Responses

Most of the commands follow the same structure: a 3 letter command followed by a colon, followed by a parameter (if any) and terminated by Carriage Return with Line Feed. A Line Feed character may be sent but it will be ignored by the RB-DSD8. Commands are not case sensitive. Responses are CR & LF terminated.

Following are the commands and the expected responses:

Command	Description	Response
ASB:n	Automatic Switch Back where n selects between two options: 0 – Manual switch back 1 – Automatic switch back	-ACK:
CHS:	Channel Status Request a is the channel set number, either 1,2,3 or 4 bb represents the presence settings, where bb is a hex value built from sum of: 0x01 – Main Left Channel Green LED on 0x02 – Main Left Channel Red LED on 0x04 – Main Right Channel Green LED on 0x08 – Main Right Channel Red LED on 0x10– Backup Left Channel Green LED on 0x20– Backup Left Channel Red LED on 0x40– Backup Left Channel Green LED on 0x80– Backup Left Channel Red LED on c is the AES setting for the current channel set where c is a hex value built from: 0x01 – Main channel AES present and not being sample rate converted 0x02 – Main channel AES present but with errors 0x03 – Main channel AES present and being sample rate converted 0x10 – Backup channel AES present and not being sample rate converted 0x20 – Backup channel AES present but with errors 0x30 – Backup channel AES present and being sample rate converted d is the selection setting for the current channel set where d is: 0x01– Main is selected 0x02 – Backup is selected e is the mode setting for the current channel set where e is: 0x01– Automatic switching 0x02 – Manual switching 0x03 – Slave mode	-CHS:a,bb_c_d_e_f_g;

Command	Description	Response
	<p>f represents the disable detection DIPswitches where f is a hex value built from:            0x01 – Main left channel detection disabled            0x02 – Main right channel detection disabled</p> <p>g represents the output format where:            0x00 – Digital output            0x01 – Analogue output</p>	
CSB:nnn	<p>Channel Status bit depth            nnn is the sum total of the settings for each channel.            For channel 1, bit depth = 0 (24 bit), 1(20 bit) or 2(16 bit)            For channel 2, bit depth = 0(24 bit), 4(20 bit) or 8(16 bit)            For channel 3, bit depth = 0(24bit), 16(20 bit) or 32(16 bit)            For channel 4, bit depth = 0(24 bit), 64(20 bit) or 128 (16 bit)            Example to set all channels to 20 bit = 1+4+16+64 = 85            so send CSB:085</p>	-ACK:
CSC:nnn	<p>Channel Status channel description            nnn is the sum total of the settings for each channel.            For channel 1, description = 0 (2 channel), 1(single channel) or 2(Stereophonic)            For channel 2, description = 0(2 channel), 4(single channel) or 8(Stereophonic)            For channel 3, description = 0(2 channel), 16(single channel) or 32(Stereophonic)            For channel 4, description = 0(2 channel), 64(single channel) or 128(Stereophonic)            Example to set all channels to single channel = 1+4+16+64 = 85 so send CSC:085</p>	-ACK:
DEF:	Return the unit to default configuration	-ACK:
DFT:	nnn Default Delay length in seconds where nnn is the number of seconds between 2 and 252	-ACK:
DIS:nn	<p>Disable silence detection            nn is a hex value built from the sum of:            0x01 – Channel 1 detection disabled            0x02 – Channel 2 detection disabled            0x04 – Channel 3 detection disabled            0x08 – Channel 4 detection disabled            0x10 – Channel 5 detection disabled            0x20 – Channel 6 detection disabled            0x40 – Channel 7 detection disabled            0x80 – Channel 8 detection disabled</p>	-ACK:
DFT: nnn	<p>Default delay length in seconds            nnn is the number of seconds between 2 and 252</p>	-ACK:
DTL:nn	<p>Silence detect level            nn sets the level of silence between -39 and -84</p>	-ACK:
DTT:nnn	<p>Delay length in seconds            nnn is the number of seconds between 2 and 252</p>	-ACK:
DWN:	Initiates a firmware upgrade	-ACK:
FSC:n	<p>Full scale settings where:            n is the the selected setting from:            0 – 24 dBFS            1 – 18 dBFS            2 – 12 dBFS</p>	-ACK:
ISL:n	<p>Input selection (manual switch)            n represents which mode has been selected            0 – Main channel selected            1 – Backup channel selected</p>	-ACK:
LKS:n	<p>Link/Selection            n selects which link channel set is being effected, where:            1 – 1 &amp; 2            2 – 3 &amp; 4            4 – 5 &amp; 6            8 – 7 &amp; 8</p>	-ACK:

Command	Description	Response
LLK:n	Fail immediately or delay on loss of lock where n selects between the two modes 0 - Use standard delay on loss of lock 1 - Fail immediately	-ACK:
LNK:n	Link channels together n selects which channel are linked, where: 0 – None are linked 1 – 1, 2, 3 & 4 are linked 2 – 1, 2, 3, 4, 5 & 6 are linked 3 – all are linked 4 – 1, 2, 3 & 4 are linked and 5, 6, 7 & 8 are linked separately	-ACK:
MAC:	MAC Address Returns the MAC address of the unit in 12 hex characters.	-MAC:XXXXXXXXXXXX
NET:x.x.x.x,y.y.y,z.z.z.z	Network Address Settings x.x.x.x is a valid IP address y.y.y is a valid subnet mask z.z.z.z is a valid gateway address	-ACK:
NOP:o,v	Network Options o is the option number 0 = Addressing Method v is the option value 0 = Static 1 = Auto IP 2 =DHCP 3 = Both DHCP and Auto IP	-ACK:
OPF:n	Output Format n represents whether the output is digital or analogue where: for channel 1+2 – OX01 for channel 3+4 – OX02 for channel 5+6 – OX04 for channel 7+8 – OX08 i.e. for analogue on outputs 1,2,3 & 4, n is OX03	-ACK:

ORT:nnn	Override Delay length in seconds where nnn is the number of seconds between 2 and 252	-ACK:
STE:n	Mono or multiple selection where n selects between the two options where: 0 – Mono mode 1 – Multiple channel mode	-ACK:
RES:n	Remote start latched or pulsed n selects between the two options where: 0 – Pulsed 1 – Latched	-ACK:
RET:nnn	Return delay length in seconds nnn is the number of seconds between 2 and 252	-ACK:
RSC:n	Remote start channel n selects which channel pair controls the remote start pulse where: 0 – 1 & 2 1 – 3 & 4 2 – 5 & 6 3 – 7 & 8	-ACK:
SAR:nn	Output sample rate selection nn selects which sample rate is selected for the output where: 00 = 32k 01 = 44.1k 02 = 48k 03 = 88.2k 04 = 96k 05 = 176.4k 06 = 192k	-ACK:
SMD:n	Switching mode n is the selected switching mode where: 0 – Automatically 1 – Manually 2 – Slave Mode	-ACK
SRQ:	Status Request	

Command	Description	Response
SYF:n	Synchronisation source select n selects which synchronisation source is used where: 0 - Input 1 1 – AES/Wordclock	-ACK:
SYM:n	Synchronisation mode select n selects which synchronisation mode is used where: 0 - Master 1 – Auto 2 - Slave	-ACK:
UID:	Unit id	-UID:RB-DSD8
VER:	Version number Where x.xxx is the firmware version	-VER:x.xxx

### Error Messages

The following error messages can be returned for illegal commands

- Err:01 = Return if command is ignored
- Err:02 = Return if command is unknown
- Err:03 = Return if wrong number of parameters
- Err:04 = Return if parameter invalid

### SCi for RB-DSD8

The free of charge Sonifex SCi software allows you to control the RB-DSD8 remotely. The interface has two tabs including a status page and a miscellaneous options page. The status of the connection, serial number & firmware versions are always visible at the bottom of the screen.

Please note: In order to edit the options on the Status and Miscellaneous pages, the RB-DSD8 must have the back panel Remote Control Enable DIPswitch set to ON (DIPswitch 9, Bank 3, see page 60).

### Status Page

**Channel Panels** - Click on the panel to select this channel pair. The drop down boxes will display the settings for the selected channel pair.

Each Channel Panel contains:

**Presence LEDs** – Indicate the current audio levels on the respective inputs.

**Link LEDs** – Indicate a link between the two adjacent channel sets.

**AES LEDs** – Indicate whether a digital signal is present and whether any sample rate conversion is occurring.

**SEL LEDs** - Indicate which input is currently being output for each channel set.

**MODE LEDs** – Indicate which switching mode is currently set for each channel group.

**Detection Disable** - Tick the box to disable silence detection for the specific channel.

**Output Format** – Select an analogue or digital output

#### Additional Controls:

**Switch Mode** – Select the switch mode for the selected channel pairs from Manual or Automatic.

**Input Selector** – Select whether Main or Backup is output for the selected channel pairs.

**Link** – Link the channel groups together so that they switch together.

**Detection Time** - The amount of time in seconds that silence is detected before a switch over.

**Return Time** - The amount of time in seconds that the audio must return at a good level before it switches back.

**Default Time** – The amount of delay time used, in seconds, if all the delay DIPswitches are placed in the OFF position.

**Override Time** – The amount of delay time used, in seconds, if the override pin is held in a latched position on the remote port.

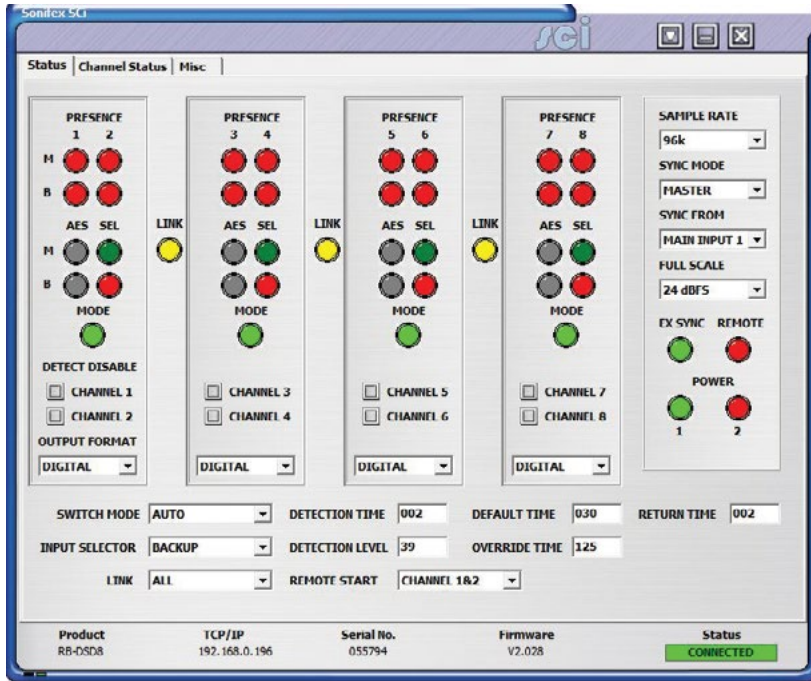

Fig 4-11: Status Page

**Remote Start/Audio Fail** – Select the channel pair which will trigger the remote start/audio fail pin on the remote connector.

**Detection Level** – The level which is considered silence in dBFS.

**Sample Rate** – Output sample rate when synchronisation mode is set to master.

**Synchronisation Mode** – Select to synchronise from the internal clock or from an external input.

**Synchronisation From** – Select which external input is used to synchronise to.

**Full Scale** – Select the full scale digit settings.

**EXT SYNC LED** - Indicates which synchronisation mode is selected.

**Remote LED** – Indicates whether the unit is being controlled remotely.

**Power LEDs** – These indicate the state of the power supplies. There is one LED for each power supply.

**Note:** All the above indicators and controls are replicas of the front panel indicators. Please read the relevant sections in the manual to ascertain the meaning of the all the different colours and settings.

## Channel Status Page

This page is used to set up the channel status for all output pairs. The bit depth and channel description can be set. Please note that the bit depth setting is not applicable on when using analogue inputs, as the ADC converts automatically to 24 bits which can not be altered.

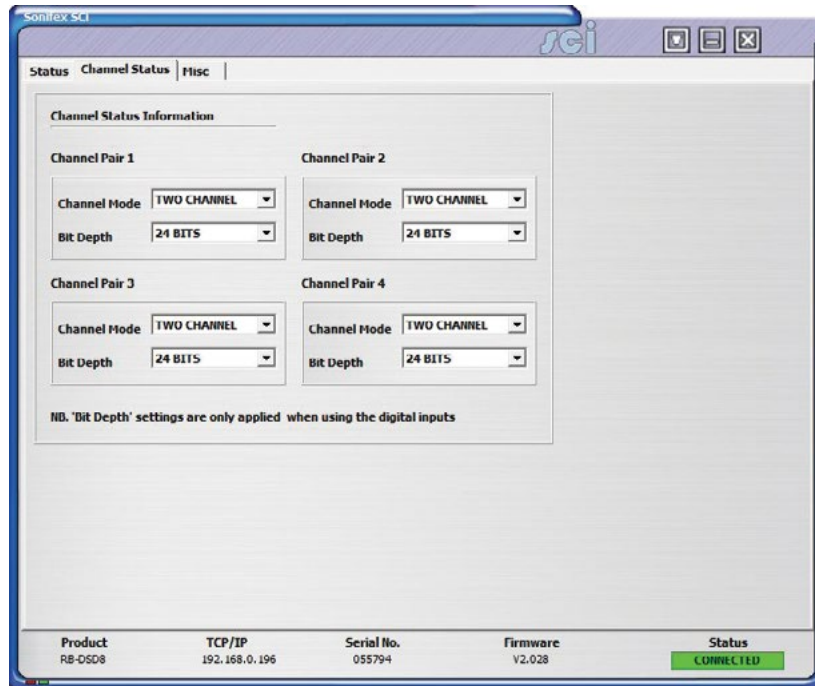

Fig 4-12: Channel Status Page

Miscellaneous Page

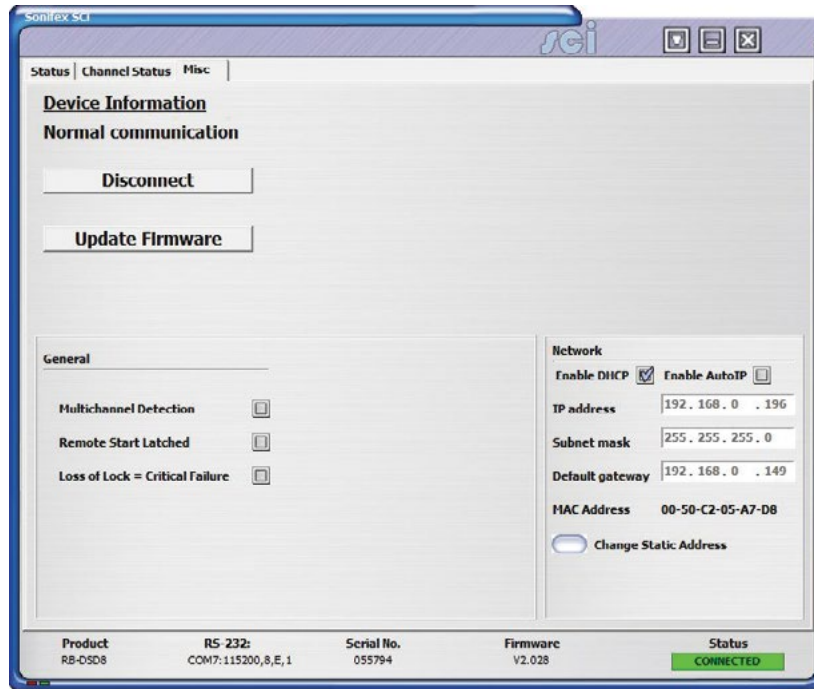

Fig 4-13: Miscellaneous Page

This page is used for the connecting and disconnecting Sci to the unit, updating the firmware in the units, displaying the current status of the unit and controlling various settings.

**Multiple Channel Detection** - If selected, all channels that are linked have to go silent before the channels swap.

**Remote Start** - If selected the unit latches the remote start signal on the GPI/O pin, otherwise it is pulsed.

**Loss of Lock Failure** - If selected the unit treats a loss of lock condition as an immediate failure rather than waiting for the detection time.

**Network** - This displays the current settings and status of the network connection on the unit.

**Enable Auto IP** - This sets the IP Address of the unit to fixed a value (169.254.1.0). If enabled please make sure the connecting PC also has this feature enabled if a successful connection is to be made. DHCP takes priority over Auto IP.

**Enable DHCP** - This enables the unit to receive it's IP address, subnet mask and gateway settings from a DHCP server. If one is not available then this should be disabled through the serial port and a valid static address entered. If the unit fails to connect via DHCP, it will connect via auto IP if enabled, or a static address if not. Please note that the DHCP connection attempts will abort after 45 seconds if unsuccessful. While connecting, the IP address, subnet mask and default gateway will all read 0. 0. 0. 0. if read serially.

**IP Address** - Displays the current IP address of the unit. If DHCP is enabled then this will normally be the IP address supplied by the DHCP server.

**Subnet Mask** - Displays the current subnet mask for the unit.

**Default Gateway** - Displays the current default gateway for the unit.

**MAC Address** - The unit's MAC address. This cannot be changed.

**Change Static Address** - This allows you to alter the static address stored in the unit. This is the address that is used when DHCP is disabled or a DHCP server is not found.

Selecting this button allows manual entry of IP, subnet and gateway addresses in the edit boxes.

**Note:** The units are discovered using broadcast packets. If your PC has two network cards, then there is a limitation in windows that requires the two addresses to be on different subnet addresses.

## Webserver

The webserver on the RB-DSD8 provides a method for the user to inspect or modify its settings. The Ethernet port should be connected to a network and then the unit will be accessible to all computers on that network - including smartphones/tablets if the network is WiFi compatible.

The screenshot displays the webserver interface for the Sonifex RB-DSD8. At the top, the Sonifex logo and 'RB-DSD8' model name are visible. Below the navigation bar (Status, Config, Update, Device Information, Defaults, Log Out), the 'General Settings' page is shown. The left column contains a list of settings with dropdown menus and checkboxes, and a 'submit' button. The right column provides a detailed view of the selected 'General Settings'.

Setting	Value
Sample Rate:	48k
Sync Mode:	Master
Sync From:	Main Input 1
Full Scale:	24 dBFS
Remote Start Channel:	Channel 1 and 2
Detection Time:	2
Return Time:	2
Detection Level:	39
Default Time:	30
Override Time:	125
Multichannel Detect:	<input type="checkbox"/>
Remote Start Latch:	<input type="checkbox"/>
Loss Of Lock Failure:	<input type="checkbox"/>

**General Settings**  
General controls apply globally to all channel pairs.

**Sample Rate**  
Sample rate of the digital outputs in master synchronisation mode.

**Synchronisation Mode**  
Selects which synchronisation mode to use:

- Master mode means the output sample rate is specified by the unit.
- Auto mode means the unit will follow the selected sync input. If the sync input is lost, the output will then follow the sample rate specified by the unit.
- Slave mode means the unit will follow the selected sync input. If the sync input is lost, the output will be lost.

**Synchronisation From**  
Selects which synchronisation input to use; Main Input 1 or External Synchronisation input.

**Full Scale**  
Select DPA line up. 0 dBFS equals either 12,18 or 24 dBu.

**Remote Start Channel**  
Select which channel controls the remote start signal.

**Detection Time**  
The time the incoming signal has to be below threshold before switching over in AUTO switch mode.

**Detection Level**  
Threshold level for the switch over point measured in -dB.

Sonifex Ltd. 61 Station Road, Irthlingborough, Northants, NN9 5QE, UK. Tel: +44 (0)1933 650700 Fax: +44 (0)1933 650726 Email: [sales@sonifex.co.uk](mailto:sales@sonifex.co.uk)

Fig 4-14: General Settings Page

## Connecting to the Device

To connect to the device you will need to know either the unit's IP address or its Bonjour Name. To connect to the device by IP address (eg 192.168.0.100) communicate via a browser by entering `http://192.168.0.100` in the address bar of the browser.

To connect via Bonjour Name in a Bonjour enabled device enter the name in the browser address bar. The default name is the device ID 'RB-DSD8', a hyphen character '-', followed by the serial number without leading zeroes '23456' and then followed by '.local/' to indicate the local domain – so RB-DSD8-23456/.local/

### First Time Usage

When you first get the unit it is set to use AutoIP and DHCP. If you have a DHCP on your server simply connect the device to your network and either run the discovery application or ask your network administrator for the assigned IP address or if you have a Bonjour enabled device enter the default name in the browser address bar as above. If DHCP is used you should be aware that disconnecting and reconnecting may NOT result in the same IP address being assigned on each connection.

If your system network is unsuitable or doesn't have a DHCP server then the unit will use AutoIP which will poll addresses in the reserved range of 169.254.x.x until it finds an unused address. Unless your network uses this mechanism for IP address assignment, this will most likely be used when connecting a PC with a network cable directly between the unit and the PC. Ensure that the PC has dynamic addressing enabled in its network options and the AutoIP system will ensure that each device has a unique ID in the 169.254.x.x range. Now using the discovery app, find the IP address or if the PC is Bonjour enabled type in the device name to the browser as above.

Finally if you are still having issues connecting – set dipswitch 6 to on (up) and power cycle the unit. This will force the device to use a static IP address of 192.168.0.100

Once connection is established in a browser go to the Network tab and set the device to the settings appropriate for your network.

### Bonjour

Bonjour is an application created by Apple and is integral to Apple operating systems and the iTunes app. Bonjour for Windows is available as a plug-in for internet explorer - go to our website or other download stores and download the appropriate version for your operating system.

### Sonifex Service Discovery App

This is a free download for Windows from our website (SfxSrvDisc.Exe) that looks for classes of devices on the network and allows you to connect via a browser to them where appropriate. If Bonjour is installed select the Bonjour tab and then the Sonifex Web Server Service to show all devices. Select the device you wish to connect to, by type and serial number, and then launch to connect via a browser. If Bonjour is unavailable go to the Legacy Discovery tab, press the Refresh button, and if the device has a webserver you can select and launch the device.

### Webserver Password

#### Password Set up and Logging in

When the webpage is first loaded, the password should be blank which means full access to the webpage is granted. To enter or change a password go to the password settings page and enter a 5 digit, case sensitive, alphanumeric password. Once submitted the password will be active and any subsequent webpage sessions will require password entry to log in. Status and device information is still available without password entry.

#### Logging out of the Webpage

A log out button will become available in the webpage menu bar, once the user is logged in. A timeout period, which logs users out automatically, can also be set on this page. A value of between 1 and 30 minutes can be set. Entering zero will disable this function.

### Clearing the Password

To clear the password, delete all characters in the password settings box and submit. A reset to defaults through any method, be it serial, webpage or through unit reset button sequence will also clear the password.

## Updating The Firmware

The RB-DSD8 firmware will at times be updated to add new features, or to correct any possible issues that may arise.

Check for updates at: <http://www.sonifex.co.uk/technical/software/>

Firmware updates can be conducted through either Serial/Ethernet port, via SCi or the webpage. To update the firmware via SCi, click on the button labelled "Update Firmware" and then select the downloaded firmware file. Firmware files for the RB-DSD8 always have a ".ldr" or ".dwn" extension. A progress bar will appear in SCi, indicating how much of the file has been uploaded to the unit. When the unit switches to update mode, the front panel display LEDs will all be extinguished. The switch mode buttons are then used to display the status of the upload:

**Uploading the Code:** The SLAVE button will begin to flash amber to confirm the unit is receiving the new firmware to RAM.

**Copying Code To Flash Memory:** The SLAVE button will be solid amber while the unit checks the integrity of the file and copies the file from RAM to flash memory.

**Successful Update:** The AUTO button will be solid green for two seconds and the unit will automatically reset and begin running the new code.

**Unsuccessful Update:** The MANUAL button will be solid red for two seconds and the unit will return to running the last code used.

To update via the webpage, browse and select an update file then click 'submit'.

**Uploading the Code and Copying Code To Flash Memory:** The SLAVE button will be solid amber while the unit checks the integrity of the file and copies the file from RAM to flash memory.

**Successful Update:** The AUTO button will be solid green for two seconds and the unit will automatically reset and begin running the new code.

**Unsuccessful Update:** The MANUAL button will be solid red for two seconds and then the unit will be automatically reset, running the old code on boot up.

## Technical Specification RB-DSD8

### Audio Specification - Digital In To Digital Out

Input & Output Impedances: 110Ω ± 20% AES/EBU balanced I/O 50Ω BNC TTL word clock input

Dynamic Range: >138dB ref. 0dBFS, 22kHz BW, unity gain

THD+N: <-137dBFS, 0dBFS, 20-20kHz, unity gain, 20kHz BW

Signal Level: Balanced: 3V/10V peak to peak min/max

Sample Rates: 32, 44.1, 48, 88.2, 96, 176.4 or 192kHz

Bit Depth: Up to and including 24 bit

### Audio Specification - Analogue In To Analogue Out

Full Scale Setting: 0dBFS = +12dBu 0dBFS = +18dBu 0dBFS = +24dBu (Software Selectable)

Maximum Input Level	+12dBu	+18dBu	+24dBu
---------------------	--------	--------	--------

Noise (A-weighted, Unity gain, RS=200Ω)	<-93dBu	<-88dBu	<-82dBu
---	---------	---------	---------

Input Impedance: >20kΩ bridging balanced

Dynamic Range: >105dB ref. +24dBu, 22kHz BW, unity gain

THD+N: <0.005%, +8dBu, 20-20kHz, unity gain, 20kHz BW

Common Mode Rejection: >60dB @ 1kHz

### Front Panel Operational Controls

Switch Mode Select: Via AUTO, MANUAL or SLAVE push-buttons

Manual Source Select: Via MAIN and BACKUP push-buttons

Group Selection : Via LINK/SELECT push-buttons

### Front Panel Indicators

Presence LEDs: For all input channels

Link LEDs: Show which channels are controlled concurrently

Mode LEDs: Indicate the current mode selected for each group

Selection LEDs: Indicate whether MAIN or BACKUP is selected

AES LEDs: Show the state of the digital input to each group

PSU LEDs: Show the state of each power supply

Remote Control LED: Show if remote control is selected

External Synchronisation LED: Show the state of any synchronisation inputs used.

### Rear Panel - Operational Controls

Silence Threshold: -27dBfs to -84dBfs in 3dBfs steps, via rear panel DIPswitches

Silence Duration: 0 - 254 seconds in 2 second intervals duration, via rear panel DIPswitches

Stereo/Mono Switching: Stereo or mono, via rear panel DIPswitch

Master Output Sample : 32, 44.1, 48, 88.2, 96, 176.4 or 192kHz, via rear panel

Rate Select: DIPswitches

Ignore Silence: Each channel can be set to ignore silences, via rear panel DIPswitches

Remote Control Enable: Enabled or disabled, via rear panel DIPswitch

Synchronisation Mode & Source Select: Synchronisation in master mode or synchronisation from MAIN input1, AES or wordclock synchronisation input in auto or slave mode, via rear panel DIPswitches

Remote Start: Latched or momentary, via DIPswitch

Input Lock Loss: Switch immediately or treat as silence delay, via rear panel DIPswitch

Digital or Analogue Output: Digital or analogue, via rear panel DIPswitches

Full Scale Line Up: 24, 18 or 12 dBu = 0dBFS, via rear panel DIPswitches

Boot Mode: Boot in boot or normal via rear panel DIPswitch

**Connections**

Digital/Analogue Inputs: 2 x 8 stereo channel inputs on 2 x 25 pin D-type male

Digital/Analogue Outputs: 1 x 8 stereo channel outputs on 1 x 25 pin D-type female

Synchronisation Inputs: 1 x BNC (Wordclock or AES/EBU)

Remote I/O Port: 25 way D-type female

SCi port: USB or ethernet

Mains Input: 2 x Universal filtered IEC, continuously rated 85-264VAC @47- 63Hz, max 60W

Fuse Rating: 2 X Anti-surge fuse 2A 20 x 5mm

**Equipment Type**

RB-DSD8: 8 channel silence switcher

**Physical Specifications**

Dimensions (Raw): 48cm (W) x 22cm (D \*) x 4.2cm (H) 1U  
19" (W) x 8.7" (D \*) x 1.7" (H) 1U

Dimensions (Boxed): 55cm (W) x 28cm (D) x 17cm (H)  
21.7" (W) x 11" (D) x 6.7" (H)

Weight: Nett: 2.3kg Gross: 3.2kg  
Nett: 5.1lb Gross: 7.0lb

\* Note that this product is deeper than standard Redboxes

**Accessories**

RB-RK3: 1U Rear panel rack kit for large Redboxes

## 5 RB-FS42 Audio Failover Switcher, 4 Main I/O, 2 Standby I/O

### Introduction



Fig 5-1: The RB-FS42 Front Panel

The RB-FS42 4 + 2 audio failover switcher is a smaller channel count version of the RB-FS82, offering a lower number of inputs and outputs. It is a more cost effective solution where failover is needed for a smaller number of sources/destinations and supports all of the features of the RB-FS82.

The device has 4 main + 2 standby, stereo analogue audio, AES/EBU digital audio and RS232 connections (both inputs and outputs) and can be configured via Ethernet for two main operational applications:

For switching of program sources to a standby destination in the event of a destination failure ('Standbys to outputs'). Typically this would be audio encoders at a program distribution head end (for audio over IP, E1 or other bearer networks), with "N" x programs feeding "N" x encoders. If an encoder fails the audio destined for that encoder gets routed to a standby encoder so ensuring the continuity of audio to network transport.

Switching of program sources, including standby sources, to destinations in the event of source failure ('Standbys to inputs'). Typically this would be audio decoders at a transmission site with "N" x programs and "N" x decoders feeding "N" x transmitters. If a decoder fails, the audio from a standby decoder, or other audio source such as an mp3 player, overrides the signal path to the transmitter so ensuring continuity on air.

The RB-FS42 supports any configuration of up to 4 main program signal paths ( $N \leq 4$ ) and there are 2 standby program signal paths, in either mode

of operation. Each program path simultaneously switches analogue L/R audio, AES/EBU digital audio and RS232 data. Each of these signals is wired on D-Type connectors on the rear panel.

All signal paths are passive and therefore completely transparent utilising relay based switching. This has the benefit of a "straight wire" topology during normal (alarm free) operation and also during any power outage to the device. An additional benefit of the passive signal path is AES/EBU bit transparency allowing throughput of AES/EBU AC3 Dolby E TM signals.

To ensure the passive nature of the device, switching is determined by alarm (General Purpose) inputs, with this alarm signalling in turn being normally provided by the encoder or decoders (or other devices) at site. Recognising the mission critical nature of the system, a high grade of relay is used in the RB-FS42.

The passive design ensures continuity of audio in the event of any power outage. However the RB-FS42 also includes dual redundant power supplies (85V-264V AC with a 12V 2A DC backup as standard). The RB-FS42-DC model accepts two DC power inputs (24 - 48V DC) via locking 2.5mm pin power connectors and both power supplies are monitored by the unit. This means that if either power supply fails, the other is ready to take over. In the extremely unlikely event that both fail, the unit's passive signal path ensures a straight wire connection for all 4 program feeds (analogue, AES/EBU & RS232). This is essential for applications such as installation

at transmitter sites, where a power failure to the unit will not prevent the audio input signal from being output to each of the supported 4 transmitters.

A row of LEDs on the front panel confirm the unit status, with each individual program path indicated as being in alarm with either Standby 1 or Standby 2 programs clearly confirmed as actively over-riding the failed signal. Alarm LEDs on the front panel are also indicated for power supply 1 failure and power supply 2 failure and these are mirrored by the device's own General Purpose Outputs so facilitating easy interfacing of the device with the addition of a summary alarm status GPO.

By monitoring and acting on a GPI Alarm pin for each signal path the unit can switch between: Through, Standby 1, Standby2 or Silence. The unit will always attempt to route a Standby path when a Main path alarm is detected and if both Standby paths are already in use, then one of the two remaining options (Through, Silence) will be used. The unit can be configured to either Automatically restore a Main 'through' path or wait for a Manual button press.

In the event of alarm clearing, the unit will automatically revert to normal operation, but a manual reversion mode is also provided, allowing for engineering investigation without the unit 'hunting' between different signal paths. Two buttons on the front panel, RESTORE 1 and RESTORE 2, allow manual restoration of the previously failed signal paths, away from Standby 1 and Standby 2 respectively.

To facilitate integration with site management systems the RB-FS42 supports SNMP V1 and is configured by a simple web based GUI. All relevant information regarding input/output status, alarms and power supplies is available via SNMP GET requests to the unit. Traps can also be generated for most of the actions which can occur, including power supply fail and input GPI alarms, etc.

Contact Sonifex for further information if you have a particular requirement that isn't catered for by the RB-FS42 as standard.

**Category:** Synchronisers, Delays & Silence Detectors.

**Product Function:** To route the source audio signals in to a standby encoder in event of encoder fail. Or to route the destination audio signals from a standby decoder in event of decoder fail.

**Typical Applications:** As a failover switcher for multi channel audio transport over E1 or IP, typically as performed by APT Oslo, Prodyss Nureus, where a N+1 topology is adopted.

**Features:**

- Relay based switching.
- Dual DC, or AC, power supplies (select when ordering).
- Encoder site (Set via IP): 4 stereo program inputs, 4 + 2 stereo program outputs where each program input/Output carries: analogue L/R, stereo AES/EBU & RS232.
- Encoder site: Each program output has an alarm detect GP input.
- Decoder Site (Set via IP): 4 +2 stereo program inputs, 4 program outputs where each program input carries: analogue L/R, stereo AES/EBU & RS232.
- Decoder Site: Each program input has an alarm detect GP input.
- AES/EBU transparent (for Dolby E transport).
- Passive throughput in event of power outage.
- GPO output for signalling RB-FS42 alarm conditions: PSU 1/2 fail, Standby 1/2 active, Summary Alarm.
- Automatic or Manual reversion modes.
- LED indicators on front panel.
- IP control, including Web GUI and SNMP.

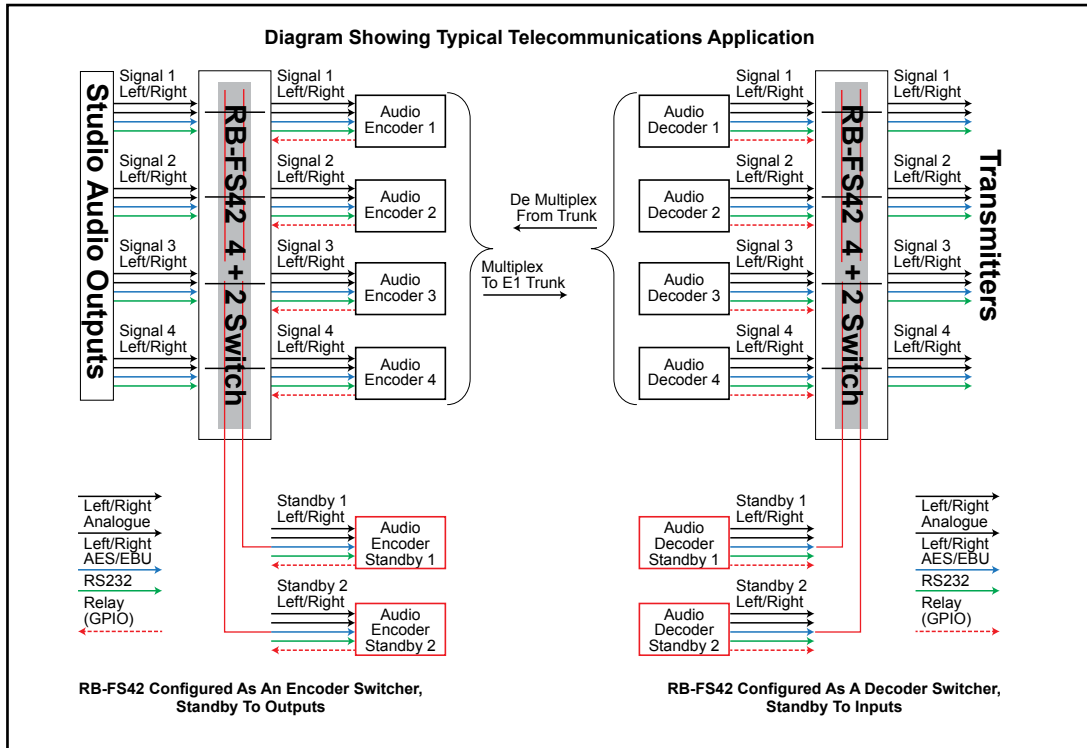

Fig 5-2: The RB-FS42 Diagram

## Connections & Operation

### Front Panel

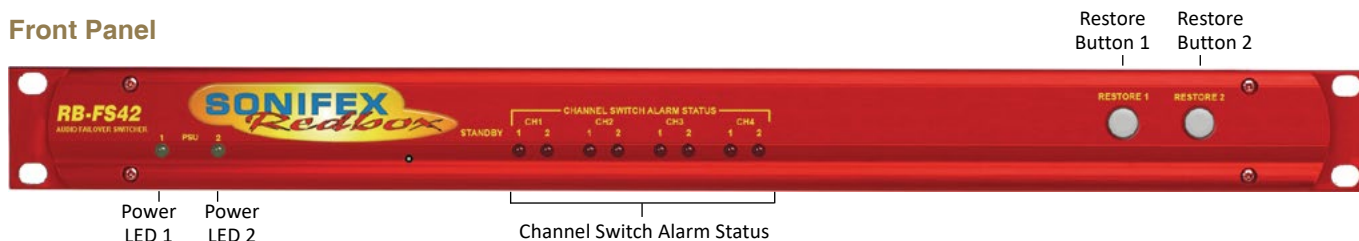

Fig 5-3: The RB-FS42 Front Panel

The front panel consists of 10 LED indicators, two lit RESTORE buttons and a recessed reset switch. The left-most pair of green LEDs are PSU indicators. Next there is a pair of red LEDs for each Main channel. The two RESTORE buttons on the right end of the panel are lit by bi-colour red/green LEDs.

The behaviour of each indicator is as follows:

#### PSU1 and PSU2

These LEDs will be on solid green when there is a valid power supply connected to the respective input on the rear panel. The LED will be off when no power is detected. The LED will flash if power is detected but the voltage is too low.

#### Channel LED 1 and 2

Each LED corresponds to the activity of the respective Standby signal (1 or 2). When both LEDs are off, the Main channel in question is routing "Through". The first LED will light if the Main channel in question is routing Standby 1 path. Conversely the second LED will light if the Main channel

is routing Standby 2 path. Both LEDs will flash for a channel that is routing "Silence" or routing "Through" whilst the input is Alarmed.

#### Restore Button LEDs

Solid green indicates that the respective Standby channel is not Alarmed and is not being used. Solid red occurs when the respective Standby channel is in an Alarmed state. Solid orange signifies that the respective Standby signal is being routed to a Main channel which is in an Alarmed state. Flashing orange indicates that the respective Standby signal is being routed to a Main channel which is no longer in an Alarmed state and is ready to be restored. This flashing orange state will only occur if the Main channel in question is not set to Auto Restore.

#### Restore Buttons

##### STANDBY RESTORE

The restore buttons can be used to perform several functions. As described above they are used to restore Main channels from Standby when those channels are configured in manual mode.

### **GLOBAL RESTORE**

You can also modify the Global Restore option by using the right-most button (RESTORE 2). Pressing and holding this button will cause the LEDs to cycle through three different indications; Double Orange, Double Red then Double Green. Each Indication corresponds to a different setting of the Global Restore option. Whilst the buttons are indicating the option you desire, let go of the RESTORE 2 button to set the Global Restore option:

- Double Orange is Global Auto Restore. Global Automatic sets all channels to auto restore, useful as a quick method of restoring multiple channels.
- Double Red is Global Manual. Global Manual, sets all channels to manual restore, which can be useful for fault finding etc.
- Double Green is Global GUI configuration. Global GUI sets each channel restore option back to that which has been configured using the web based GUI.

### **Factory Reset**

The two RESTORE buttons can also be used for two special reset cases. Holding RESTORE 1 while the unit is power cycled or reset, will cause the unit configuration to be reset to factory defaults. All options are reset to defaults including any network settings that have been modified. The PSU Status LEDs will flash when the unit reboots to indicate that the factory reset has taken place.

### **Boot Mode**

Holding both RESTORE buttons while the unit is power cycled or reset, will cause the unit to revert to Bootstrap Mode.

**Warning:** This removes the main firmware from the unit and should not be necessary unless the unit has been loaded with incorrect or corrupted firmware. Once in Bootstrap Mode you will need to load correct main firmware back into the unit using the web based GUI as normal.

## Rear Panel Connections

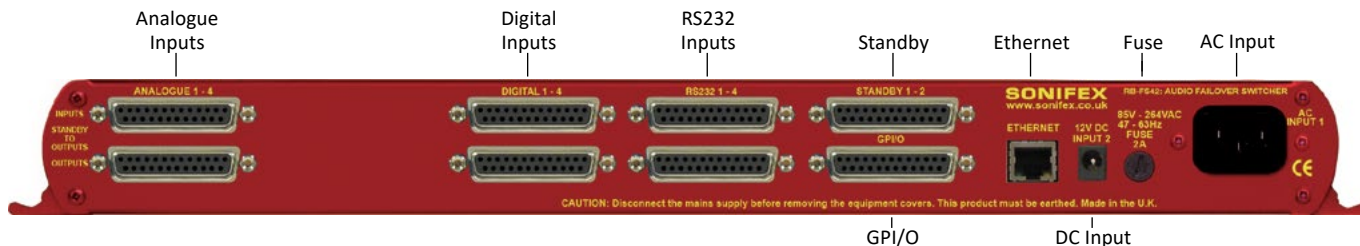

Fig 5-4: The RB-FS42 Rear Panel

The back panel consists of 18 x 25 way D-Type sockets, an Ethernet port and power inlets.

### Ethernet Port

The Ethernet port is a standard RJ-45 connector on the rear panel. It is a 10/100Mbps link and has green and amber indicators for link status and speed selection. The unit can be controlled remotely over the Ethernet connection using the built-in webserver. By default the unit is configured for dynamic addressing using DHCP.

The connections for the RJ45 connector are as follows:

Ethernet Connector (RJ-45)			
Pin No.	Function	Pin No.	Function
Pin 1	Transmit data (+)	Pin 5	No connection
Pin 2	Transmit data (-)	Pin 6	Receive data (-)
Pin 3	Receive data (+)	Pin 7	No connection
Pin 4	No connection	Pin 8	No connection

### AC Power Input

The AC power is applied via a standard three-pin IEC male socket. Mains voltages between 85V and 264V AC and frequencies between 47 and 63Hz are accepted without adjustment.

A 2A, 5 x 20mm SB fuse is used. The Earth pin MUST be connected to ensure safety.

### DC Power Input

The DC power is applied via a locking 2.5mm power socket 1 x 12V 2A DC supply,

### Analogue, AES/EBU Digital & RS232 Input & Outputs

The top row of D-Types take the input signals and from left to right correspond to; Analogue Channels 1 – 4, Digital Channels 1 – 4 and Standby Channels 1 and 2 for each signal type.

The first four bottom D-Types from left to right supply the output signals for the corresponding inputs above them.

See the 'D-Type Connection Details' section for specific connection details for each connector.

## 25 Way D-Type Connection Details

The following table gives the pin out for the main analogue, digital and RS232 input and output channels, according to standard D-Type pin ordering.

Pin No	Analogue 1 Signals (Channels 1 - 4)	AES/EBU Digital Signals	RS232 Signals
Pin 1	Ch1 L - Phase	Ch1 - Phase	Ch1 - TXD
Pin 14	Ch1 L - Non-Phase	Ch1 - Non-Phase	Ch1 - RXD
Pin 2	Screen	Screen	Screen
Pin 15	Ch1 R - Phase	Ch2 - Phase	Ch2 - TXD
Pin 3	Ch1 R - Non-Phase	Ch2 - Non-Phase	Ch2 - RXD
Pin 16	Screen	Screen	Screen
Pin 4	Ch2 L - Phase	Ch3 - Phase	Ch3 - TXD
Pin 17	Ch2 L - Non-Phase	Ch3 - Non-Phase	Ch3 - RXD
Pin 5	Screen	Screen	Screen
Pin 18	Ch2 R - Phase	Ch4 - Phase	Ch4 - TXD
Pin 6	Ch2 R - Non-Phase	Ch4 - Non-Phase	Ch4 - RXD
Pin 19	Screen	Screen	Screen
Pin 7	Ch3 L - Phase	Ch5 - Phase	Ch5 - TXD
Pin 20	Ch3 L - Non-Phase	Ch5 - Non-Phase	Ch5 - RXD
Pin 8	Screen	Screen	Screen
Pin 21	Ch3 R - Phase	Ch6 - Phase	Ch6 - TXD
Pin 9	Ch3 R - Non-Phase	Ch6 - Non-Phase	Ch6 - RXD
Pin 22	Screen	Screen	Screen
Pin 10	Ch4 L - Phase	Ch7 - Phase	Ch7 - TXD
Pin 23	Ch4 L - Non-Phase	Ch7 - Non-Phase	Ch7 - RXD
Pin 11	Screen	Screen	Screen
Pin 24	Ch4 R - Phase	Ch8 - Phase	Ch8 - TXD
Pin 12	Ch4 R - Non-Phase	Ch8 - Non-Phase	Ch8 - RXD
Pin 25	Screen	Screen	Screen
Pin 13	N/C	N/C	N/C

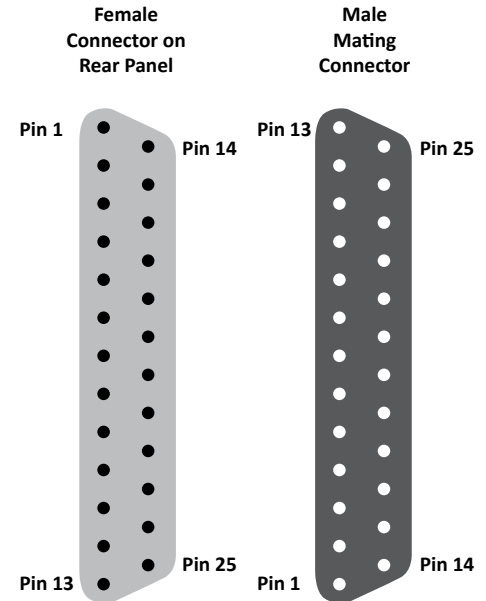

Fig 5-5: The RB-FS42 Female and Male Connectors

**GPIO Connector**

The last D-Type on the bottom of the rear panel is the GPIO connector and is the location of the 10 GPI Alarm pins corresponding to each of the input signal paths. The 10 pins for the closing contact alarms generated by the RB-FS82 are also here, along with ground reference pins to facilitate the operation of the GPIs in active low mode.

Pin No.	Signal	I/O	Description
Pin 1	GPO1-1	O	Closing Contact Alarm 1
Pin 14	GPO1-2	O	Closing Contact Alarm 2
Pin 2	GPO2-1	O	Closing Contact Alarm 3
Pin 15	GPO2-2	O	Closing Contact Alarm 4
Pin 3	GPO3-1	O	Closing Contact Alarm 5
Pin 16	GPO3-2	O	Closing Contact Alarm 6
Pin 4	GPO4-1	O	Closing Contact Alarm 7
Pin 17	GPO4-2	O	Closing Contact Alarm 8
Pin 5	GPO5-1	O	Closing Contact Alarm 9
Pin 18	GPO5-2	O	Closing Contact Alarm 10
Pin 6	GPI-1	I	General Purpose Input 1 - Alarm Signal
Pin 19	GPI-2	I	General Purpose Input 2 - Alarm Signal
Pin 7	GPI-3	I	General Purpose Input 3 - Alarm Signal
Pin 20	GPI-4	I	General Purpose Input 4 - Alarm Signal
Pin 8	GPI-5	I	General Purpose Input 5 - Alarm Signal
Pin 21	GPI-6	I	General Purpose Input 6 - Alarm Signal
Pin 9	GPI-7	I	General Purpose Input 7 - Alarm Signal
Pin 22	GPI-8	I	General Purpose Input 8 - Alarm Signal
Pin 10	GPI-9	I	General Purpose Input 9 - Alarm Signal
Pin 23	GPI-10	I	General Purpose Input 10 - Alarm Signal
Pin 11	N/C	-	
Pin 24	N/C	-	
Pin 12	DGND	-	Ground Return for External Circuits
Pin 25	DGND	-	Ground Return for External Circuits
Pin 13	DGND	-	Ground Return for External Circuits

**Standby 1 - 2 Connector**

The following table gives the connections for the Standby Channel connectors.

Pin No.	Type	Signal
Pin 1	Standby 1 RS232	SB1-TXD
Pin 14	Standby 1 RS232	SB1-RXD
Pin 2	Screen	SCREEN
Pin 15	Standby 2 RS232	SB2-TXD
Pin 3	Standby 2 RS232	SB2-RXD
Pin 16	Screen	SCREEN
Pin 4	Standby 1 AES/EBU Phase	SB1 Digital P
Pin 17	Standby 1 AES/EBU Non-Phase	SB1 Digital NP
Pin 5	Screen	SCREEN
Pin 18	Standby 2 AES/EBU Phase	SB2 Digital P
Pin 6	Standby 2 AES/EBU Non-Phase	SB2 Digital NP
Pin 19	Screen	SCREEN
Pin 7	Standby 1 Analogue Left Phase	SB1 Left P
Pin 20	Standby 1 Analogue Left Non-Phase	SB1 Left NP
Pin 8	Screen	SCREEN
Pin 21	Standby 1 Analogue Right Phase	SB1 Right P
Pin 9	Standby 1 Analogue Right Non-Phase	SB1 Right NP
Pin 22	Screen	SCREEN
Pin 10	Standby 2 Analogue Left Phase	SB2 Left P
Pin 23	Standby 2 Analogue Left Non-Phase	SB2 Left NP
Pin 11	Screen	SCREEN
Pin 24	Standby 2 Analogue Right Phase	SB2 Right P
Pin 12	Standby 2 Analogue Right Non-Phase	SB2 Right NP
Pin 25	Screen	SCREEN
Pin 13	-	N/C

## Typical Application

The primary application of the RB-FS42 is to monitor the status of 4 main signal groups and, in the event of an alarm status, route one of 2 standby signal groups accordingly. The statuses of both the 4 main signal groups and the 2 standby groups are monitored via GPI pins located on the rear of the unit. In this example, the term ‘passive through’ refers to the input being routed to the output directly.

Imagine you have your 4 main signal groups from decoders, for example, connected through the RB-FS42 to encoders. You would also have up to 2 standby signal groups connected to the standby inputs on the rear of the RB-FS42 and each decoder status would be relayed to the RB-FS42 using the GPI connections on the rear of the unit.

Whilst each decoder is working as expected, all GPI pins are inactive and the RB-FS42 is passively routing all of the decoded signal groups to the encoders connected at its outputs. All of the red indicators on the front panel are off and the two RESTORE buttons are illuminated green to show that they are not in use.

### Failure Detection

When a problem occurs with decoder 6, for example, it activates the relevant GPI pin to alarm main signal group 6. The RB-FS42 immediately switches standby group 1 to main signal group 6 output. The corresponding red standby indicator illuminates for group 6 on the front panel of the RBFS42.

Also the RESTORE 1 button becomes illuminated orange to indicate that standby signal group 1 is in use.

Now imagine that decoder 4 were to fail as well. The RB-FS42 senses the alarm GPI status and immediately switches standby signal group 2 to main signal group 4 output. Again, the corresponding red standby indicator illuminates for group 4 on the front panel of the RB-FS42 and the RESTORE

2 button becomes illuminated orange to indicate that standby signal group

2 is in use.

If any more decoders were to signal an alarm status, the RB-FS42 would be unable to switch the output in question to a standby signal group, as both are already in use. In this case you may configure the behaviour in one of two ways; the RB-FS42 can either continue to route through the signal group despite the alarmed state, or the RB-FS42 can break the signal paths and route “silence” instead. In either case, both of the red front panel indicators flash simultaneously to indicate that a signal source is alarmed and is not routing a standby signal group.

### Setting a Priority Signal Input

There is a Priority feature which can be configured for any one of the 4 main signal groups. Following the example above, if main signal group 1 were defined as the priority and it was to become alarmed (whilst both standby signal groups were already being used by main groups 6 and 4), then the most recently routed standby signal group, in this case standby 2, would be “stolen” by signal group 1 and main signal group 4 would route either “silence” or passive through.

### Restoring Signals

Now let’s say that decoder 4 begins functioning normally and removes its alarm status. If signal group 4 is configured to Automatic Restore mode, the RB-FS42 immediately switches the signal path back to passive through, if it was not already in this state. The red front panel indicators for signal group 4 both turn off to indicate that there is no longer an alarm condition.

If signal groups 6 and 1 are both configured as Manual Restore mode, when their respective alarm conditions are lifted the RB-FS42 indicates that each channel can now be restored by flashing the relevant RESTORE button orange. Pressing the RESTORE button turns off the red front panel indicators for the relevant signal group and also illuminates the RESTORE button green to show that this standby signal group is no longer in use.

### **GPI Operation**

There are GPI pins to sense the status of the 2 standby signal groups as well. If the status of a standby group becomes alarmed whilst it is being routed to one of the 4 main signal outputs, then the main signal output switches to its routing preference, either silence or passive through. This is equivalent to having the standby signal stolen by a higher priority main signal group.

### **Power Supply Monitoring**

The RB-FS42 monitors each power supply connection and displays a status and an approximate voltage reading for both on the webpage. When a power supply is operating at an acceptable level the front panel green indicator will be on solidly. If though a 12V battery pack was connected to the DC input which was in a state of discharge, it may only produce 10.5V - anything below 11V is seen by the RB-FS42 as a fault. In this case the green front panel indicator flashes to indicate this and any associated enabled alarms or SNMP traps are also generated.

### **Alarm Output Relays & SNMP**

There are 5 closing contact relays present on the rear panel GPIO connector. These are used to create alarms from the RB-FS42 in various circumstances. There is an alarm for the validity of each power supply, one to show the usage state of each standby signal group and a summary alarm, which is active whenever any other alarm is present.

In addition to these physical alarm signals the RB-FS42 can generate SNMP Traps upon most actions: PSU failure, PSU return, Standby activation/deactivation and any change to a main signal group routing. The current status of all main and standby signal group inputs and outputs, along with power supply states and levels can be read back by a Network Management System (NMS) using SNMP Get functionality.

The configuration of the options and alarms mentioned above is performed via the built in web browser based GUI.

## **Network Discovery & Webserver Configuration**

In addition to any physical controls the RB-FS42 has a built in webserver which can allow you to control and configure the unit remotely through a web browser. The webpage interface also enables you to view status information, alter network settings, and update product firmware.

The RB-FS42 network interface employs Zeroconf networking, meaning that it supports DHCP, AutoIP and MDNS-SD using Bonjour. We provide a free application available for download from our website ([www.sonifex.co.uk/technical/software](http://www.sonifex.co.uk/technical/software)), to facilitate the discovery and use of Sonifex network enabled hardware, see below for more information.

### **Connecting to the Unit:**

Connecting to the webpage interface is as simple as typing the IP address of the unit into the address bar of a web browser on a PC connected to the same network.

### **DHCP**

The RB-FS42 will have DHCP and AutoIP enabled by default, if your network has a DHCP server then the unit will be assigned an IP address which can be found easily by using the Sonifex service discovery application, or by contacting your network administrator. The nature of DHCP means that the unit is not guaranteed to maintain a fixed IP address each time it is reconnected to the network. See the section on static network settings below for information on how to fix the IP address of the unit.

### **AutoIP**

If your network does not support DHCP or it is disabled, then with AutoIP enabled the unit will assign itself an IP address from the AutoIP range (169.254.1.0 to 169.254.254.255). Once an AutoIP address has been assigned you will need to connect the unit directly to a PC using an Ethernet cable. Ensure that the PC has dynamic addressing enabled and you will be able to use the Sonifex discovery application on this mini network to access the webpage interface.

### Static Network Settings

Accessing the webpage interface allows you to configure the network settings as you like. To give the unit a fixed network address, enter appropriate static details and disable both DHCP and AutoIP. The unit will now apply the static network settings whenever it is connected to a network.

### MDNS-SD and Bonjour

Bonjour is a hardware discovery service developed by Apple and as such it is natively supported by Apple devices and operating systems. Bonjour for Windows is available, go to our website ([www.sonifex.co.uk/technical/software](http://www.sonifex.co.uk/technical/software)) or other download stores and download the appropriate version for your operating system.

On a Bonjour enabled device or system, you can connect to a unit using only its hostname. By default the hostname for the RB-FS42 will be the hardware ID appended by the unique serial number of the unit:

**[Hardware ID] – [Serial No.]**

**RB-FS42-654321**

To connect to a unit using Bonjour you can simply discover and launch the webpage interface from the Sonifex service discovery application. Alternatively you can simply type the hostname appended by the local domain name into the address bar of your web browser, for the example above you would enter the following:

**RB-FS42-654321.local.**

The hostname is independent of the IP address and this means that the unit can always be discovered and accessed in this way, regardless of which IP address it has been assigned by a DHCP server. The hostname can be changed to make it more memorable or descriptive of an implementation, however, conflicting names should be avoided.

### Sonifex Service Discovery App

This is a free download for Windows, available from our website ([www.sonifex.co.uk/technical/software](http://www.sonifex.co.uk/technical/software)). This application uses Bonjour to locate networked hardware and discover what services it has to offer. On a device or system running Bonjour you can discover Sonifex hardware and launch the webserver interface if available. The application also offers legacy discovery for systems which do not support Bonjour or for Sonifex hardware which is not running MDNS-SD.

The web based GUI has a menu bar that allows you to navigate through various pages to configure different aspects of the unit. Each page follows the same standard layout as the Home page, with current status/configuration settings on the left and tooltip explanations in the box on the right. The page footer contains contact details for Sonifex LTD. A brief overview of each page follows:

**Home:** This page allows you to view the current status of the input/output ports and the power supplies. The page automatically updates to show current data from the unit.

**Device Info:** This page useful information about the unit you are connected such as the Version Number, Serial Number, MAC Address and active Network Address.

**Network:** This page allows you to change the network settings of the unit.

**SNMP:** This page allows you to change the community string for this unit. You can also configure, enable / disable, up to 3 SNMP trap destinations, which will receive any SNMP traps generated by the RB-FS42 as it functions.

**Channels:** This page allows you to configure various settings for each of the 10 channels (4 Main and 2 Standby). At the top there are two global settings, Global Restore, which is described previously, and Priority. The Priority setting allows the implementation to favour one channel above

all others. This basically means that in the event of the Priority channel becoming Alarmed whilst both Standby channels are already in use, the Priority channel will “steal” a Standby channel from one of the other, lower priority channels.

For each of the 4 Main channels you can specify whether the path should Auto restore or not, and you can pick the routing preference for when no Standby is available. There is the option to select whether you want the GPI alarm pin to be active high or active low for each channel. You can also enable and disable various SNMP traps relating to each channel here. For the standby channels there are more SNMP trap enable/disable options.

**Power:** This page allows you to enable/disable various SNMP traps relating to PSU1 and PSU2.

**GPO:** This page lets you mask/unmask the Alarms (closing contacts) generated from the FS42. Useful, for example, if you are only going to be using PSU1 you can prevent the PSU2 alarm from activating.

**LEDs:** This page simply lets you control the relative brightness of the LEDs on the front panel, in graduated steps from 1 – 5, with 5 being the brightest.

**Update:** This page allows you to load new firmware into the unit. Simply browse to the location of the correct .dwn file and click update.

**Reset to Defaults:** This is a button which restores the majority of the units settings to default values.

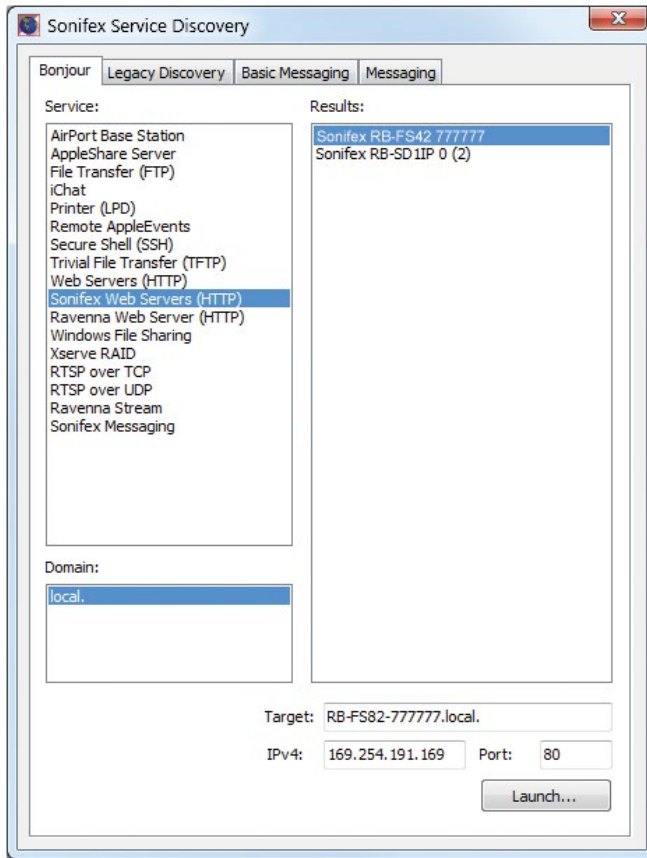

Fig 5-6: The RB-FS42 Bonjour Panel

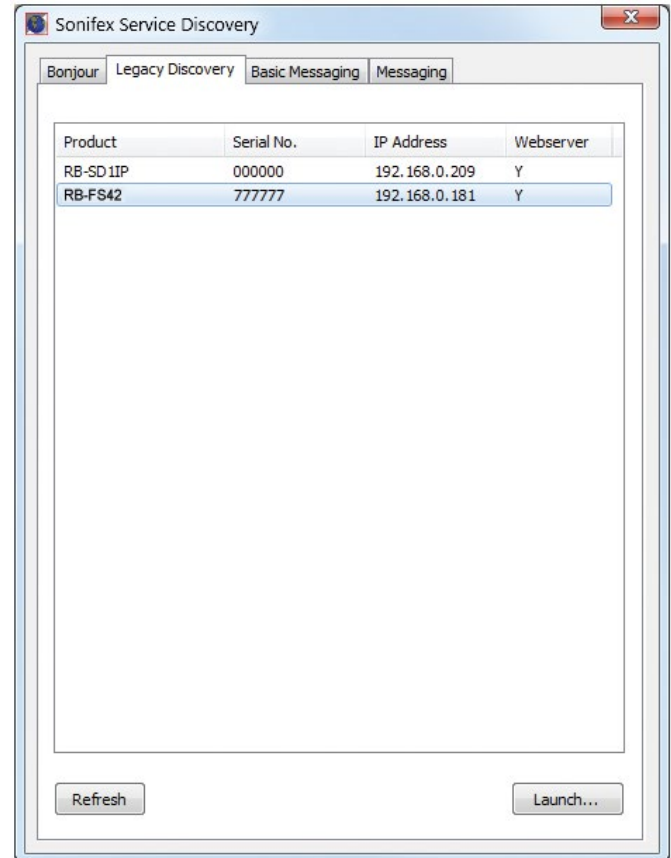

Fig 5-7: The RB-FS42 Legacy Discovery Panel

## Device Info

**SONIFEX**  
Manufacturers of audio & video  
equipment for radio & TV studios

**RB-FS42**

Home Device Info Network Configuration Update Set to Defaults

**DEVICE**

Device: RB-FS42  
Serial Number: 777777  
Description: Redbox Failover Switch 8 Main, 2 Standby  
Firmware Version: V1.03

**NETWORK**

Host Name: RB-FS42-77777  
Active IP Address: 192.168.0.220  
Active Netmask: 255.255.255.0  
Active Gateway: 192.168.0.149  
MAC Address: 00.50.C2.05.A9.BE

**Device Information**

This page shows general information about the connected RB-FS42.

Sonifex Ltd, 81 Station Road, Wellingborough, Northants, NN9 5QE, UK. Tel: +44 (0)1933 650700 Fax: +44 (0)1933 650720 Email: [sales@sonifex.co.uk](mailto:sales@sonifex.co.uk)

Fig 5-8: The RB-FS42 Device Info Panel

**Device Info:** This page useful information about the unit you are connected such as the Version Number, Serial Number, MAC Address and active Network Address.

## Home Page

The screenshot displays the RB-FS42 Home Page. At the top, the SONIFEX logo is on the left, and 'RB-FS42' is on the right. Below the logo is the text 'Manufacturers of audio & video equipment for radio & TV studios'. A navigation bar includes 'Home', 'Device Info', 'Network', 'Configuration', 'Update', and 'Set to Defaults'. The 'Configuration' menu is open, showing options for SHMP, Channels, Power, GPIO, and LEDs. The main content area is divided into two columns. The left column, titled 'HOME', shows 'Input Status' with 8 indicators (1-4, S1, S2) and 'Output Status' with 4 indicators (1-4). Below this is 'PSU Status' for PSU 1 and PSU 2, showing voltages of 12.0V and 12.7V respectively. The right column, titled 'Home Page', contains sections for 'Input Status', 'Output Status', and 'Power Supply Status', each with explanatory text. A note at the bottom of the right column explains the labeling for standby channels. At the very bottom, contact information for Sonifex Ltd is provided.

Fig 5-9: The RB-FS42 Home Screen

**Input Status**

The current status of the 4 main input channels and each of the 2 standby channels. Green indicates a valid signal and red indicates an invalid signal.

**Output Status**

The current status of the 4 output channels. Green indicates a valid signal, red indicates an invalid signal and grey indicates that the channel is routing silence. If the channel is routing a standby signal, the standby channel number will appear inside the indicator.

**Note:** The Status for standby 1 and 2 are labelled "I" and "II" respectively. This is to allow clear indication of when a specific channel is routing a standby signal.

**Power Supply Status**

The current status and an approximate voltage of each power supply are shown here. Red indicates that the voltage supplied is not within the acceptable range.

## Network Settings

**NETWORK SETTINGS**

Host Name:

IP Address:

Netmask:

Gateway:

DHCP:  Enable  Disable

Auto IP:  Enable  Disable

**Network Settings**

**Host Name**  
The Host Name for this unit is used for Multicast DNS Service Discovery. The default Host Name is the unit Hardware Type, appended with the unique Serial Number.

**IP Address**  
Please enter the static IP Address that you wish to assign to this unit. The address must be in the correct form and the default address is: 192.168.0.100

**Netmask**  
Please enter the Netmask of the network you wish to connect to. The default subnet mask is: 255.255.255.0

**Gateway**  
Please enter the Gateway Address of your router. The default gateway address is: 192.168.0.149

**DHCP**  
Disable to prevent the unit from requesting a dynamic address from a DHCP server.

**Auto IP**  
Disable to prevent the unit from assigning itself an address from the Auto IP range.

**NOTE:** With both DHCP and Auto IP disabled the unit will use the static network settings entered here.

Sonifex Ltd. 61 Station Road, Irthlingborough, Northants, NN19 5QE, UK. Tel: +44 (0)1933 650700 Fax: +44 (0)1933 650726 Email: [sales@sonifex.co.uk](mailto:sales@sonifex.co.uk)

Fig 5-10: The RB-FS42 Network Settings Screen

**Host Name**

The Host Name for this unit is used for Multicast DNS Service Discovery. The default Host Name is the unit Hardware Type, appended with the unique Serial Number.

**IP Address**

Please enter the static IP Address that you wish to assign to this unit. The address must be in the correct form and the default address is: 192.168.0.100

**Netmask**

Please enter the Netmask of the network you wish to connect to. The default subnet mask is: 255.255.255.0

**Gateway**

Please enter the Gateway Address of your router. The default gateway address is: 192.168.0.149

**DHCP**

Disable to prevent the unit from requesting a dynamic address from a DHCP server.

**Auto IP**

Disable to prevent the unit from assigning itself an address from the Auto IP range.

**Note:** With both DHCP and Auto IP disabled the unit will use the network settings entered above.

## SNMP

**SONIFEX**  
Manufacturers of audio & video equipment for radio & TV studios

**RB-FS42**

Home | Device Info | Network | Configuration | Update | Set to Defaults

### SNMP

Community String:

Destination IP 1:

Destination IP 2:

Destination IP 3:

Destination 1:  Enabled  
 Disabled

Destination 2:  Enabled  
 Disabled

Destination 3:  Enabled  
 Disabled

**SNMP**

**Community String**  
The community string may be up to 20 characters long.

**Trap Destination IP Addresses**  
You can set up to 3 different IP addresses which will receive all traps generated by the **RB-FS42**. Each destination can be enabled or disabled individually.

NOTES: The default community string is "public". It is recommended that you change this to make it harder to guess, or descriptive of the implementation. However, SNMP Version 1 community strings are not secure - they are sent as raw bytes over the network, i.e. there is no encryption.

Sonifex Ltd, 61 Station Road, Wellingborough, Northants, NN9 5QE, UK. Tel: +44 (0)1933 650700 Fax: +44 (0)1933 650726 Email: [sales@sonifex.co.uk](mailto:sales@sonifex.co.uk)

Fig 5-11: The RB-FS42 SNMP Screen

**Community String**

The community string may be up to 20 characters long.

**Trap Destination IP Addresses**

You can set up to 3 different IP addresses which will receive all traps generated by the RB-FS42. Each destination can be enabled or disabled individually.

**Note:** The default community string is "public". It is recommended that you change this to make it harder to guess, or descriptive of the implementation. However, SNMP Version 1 community strings are not secure - they are sent as raw bytes over the network, i.e. there is no encryption.

## Channel Settings

**CHANNELS**

Global Restore: Per Channel

Priority: None

Select Channel: 1

Status Trap:  Enable  Disable

Restore:  Auto  Manual

Route Pref:  Through  Silence

GPI Alarm:  Active Low  Active High

**Channel Settings**  
Select each Channel you wish to configure from the drop down list and change the settings as required. You may configure all channels before submitting.

**Global Restore**  
You can choose to use restore options as configured for each individual channel (Per Channel), or set global Auto/Manual. Note that this setting can also be controlled physically from the front panel of the unit.

**Priority**  
One of the 4 main channels can be set as a priority route for a standby signal. This priority channel will "steal" a standby signal, if necessary, from another channel when it detects a failure.

**Status / Active / Inactive - Trap**  
Enable or disable the SNMP Trap generated when the output status of a channel changes. There are also Traps to indicate when a standby signal is in use (Active) or not (Inactive).

**Restore**  
The RB-FS42 can either automatically restore a channel from standby when the signal comes up, or wait for the user to manually restore the signal path.

**Route Preference**  
When alarmed, the first routing preference is always a standby channel. If no standby signal is available, the unit can either pass through the original signal or route silence.

**GPI Alarm**  
Each of the 10 Channel Alarm GPI pins can be Active Low (alarmed when pulled to ground) or Active High (alarmed when left open).

Sonifex Ltd, 61 Station Road, Wellingborough, Northants, NN9 5QE, UK. Tel: +44 (0)1933 650700 Fax: +44 (0)1933 650726 Email: [sales@sonifex.co.uk](mailto:sales@sonifex.co.uk)

Fig 5-12: The RB-FS42 Channel Settings Screen

Select each Channel you wish to configure from the drop down list and change its settings as required. Once you have configured all channels, hit submit.

### Global Restore

You can choose to use restore options as configured for each individual channel (Per Channel), or set global Auto/Manual.

**Note:** this setting can also be controlled physically from the front panel of the unit

### Priority

One of the 4 main channels can be set as a priority route for a standby signal. This priority channel will "steal" a standby signal, if necessary, from another channel when it detects a failure.

### Status / Down / Up / Active / Inactive - Trap

Enable or disable the SNMP Trap which is generated when this channel changes output status, goes down or comes back up. There are additional Traps to indicate when a standby signal is active (in use) or inactive (not used).

### Restore

The RB-FS42 can either automatically restore a channel from standby when the signal comes up, or wait for the user to manually restore the signal path.

### Route Preference

When a channel is down, the first routing preference is always a standby channel, if both standby signals are in use by channels with higher priority, the RB-FS42 can either pass through the original signal or route silence.

### GPI Alarm

Each of the 10 Channel Alarm GPI pins can be Active Low (alarmed when pulled to ground) or Active High (alarmed when left open).

## Power Supply Trap Settings

**SONIFEX**  
Manufacturers of audio & video equipment for radio & TV studios

**RB-FS42**

Home | Device Info | Network | Configuration | Update | Set to Defaults

**POWER**

PSU 1 Down Trap:  Enable  
 Disable

PSU 1 Up Trap:  Enable  
 Disable

PSU 2 Down Trap:  Enable  
 Disable

PSU 2 Up Trap:  Enable  
 Disable

**Power Supply Trap Settings**

**Traps**

This page lets you enable or disable SNMP Trap generation for specific events on each power supply. This is useful if you are only using one power supply, as you can prevent the unit from raising an unnecessary alarm with your NMS.

Sonifex Ltd. 61 Station Road, Irlthingborough, Northants, NN9 5QE, UK. Tel: +44 (0)1933 650700 Fax: +44 (0)1933 650726 Email: [sales@sonifex.co.uk](mailto:sales@sonifex.co.uk)

Fig 5-13: The RB-FS42 Power Supply Trap Settings Screen

### Traps

This page lets you enable or disable SNMP Trap generation for specific events on each power supply. This is useful if you are only using one power supply, as you can prevent the unit from raising an unnecessary alarm with your NMS.

## GPO Settings

**SONIFEX**  
Manufacturers of audio & video equipment for radio & TV studios

**RB-FS42**

Home | Device Info | Network | Configuration | Update | Set to Defaults

**GPO**

**PSU 1 Fail:**  Enable  Disable

**PSU 2 Fail:**  Enable  Disable

**Standby 1 Active:**  Enable  Disable

**Standby 2 Active:**  Enable  Disable

**Summary Alarm:**  Enable  Disable

**GPO Settings**  
**GPO Masks**  
There are 5 closing relay contact GPOs on the **RB-FS42** and each is used to physically output one of the 5 main alarms from the unit. This page enables you to enable or disable the action of each alarm relay.

Sonifex Ltd. 61 Station Road, Irthlingborough, Northants, NN19 5QE, UK. Tel: +44 (0)1933 650700 Fax: +44 (0)1933 650726 Email: [sales@sonifex.co.uk](mailto:sales@sonifex.co.uk)

Fig 5-14: The RB-FS42 GPO Settings Screen

**GPO Masks**

There are 5 closing relay contact GPOs on the RB-FS42 and each is used to physically output one of the 5 main alarms from the unit. This page enables you to enable or disable the action of each alarm relay.

## LED Settings

**SONIFEX**  
Manufacturers of audio & video equipment for radio & TV studios

**RB-FS42**

Home | Device Info | Network | Configuration | Update | Set to Defaults

**LEDs**

Brightness Level: 3

submit

**LED Settings**  
**Brightness**  
This page allows you to select the brightness of the LEDs on the front panel of the **RB-FS42**. There are 5 options, with option 1 being the least bright.

Sonifex Ltd 61 Station Road, Litchingborough, Northants, NN19 5QE, UK. Tel: +44 (0)1933 650700 Fax: +44 (0)1933 650726 Email: [sales@sonifex.co.uk](mailto:sales@sonifex.co.uk)

Fig 5-15: The RB-FS42 LED Settings Screen

### Brightness

This page allows you to select the brightness of the LEDs on the front panel of the RB-FS42. There are 5 options, with option 1 being the least bright.

## Update



Fig 5-16: The RB-FS42 Update Screen

The current firmware version on this unit is shown at the top of the page. To find out if there is new firmware for your unit, check our website.

If an update is available, download the latest file from our website in the '.DWN' format.

Browse your computer to locate the appropriate firmware file. Once the correct file has been selected, hit submit/update.

**Note:** If updated with incorrect or corrupt firmware it may be necessary to recover the unit from boot mode. See the Handbook for details.

## Technical Specifications RB-FS42

### Audio Specification - Digital

The RB-FS42 uses passive fixed switching relays which don't affect the overall audio performance

### Audio Specification - Analogue

Crosstalk: >86dB

### Front Panel Operational Controls

Manual Switching: Via Restore 1 & Restore 2 push-buttons

### Front Panel Indicators

Power LEDs: 2 x Power indicators

Channel Status LEDs: 8 x Standby status indicators, 2 per channel.

Standby Restore LEDs: 2 x illuminated buttons.

### Rear Panel Connections

Analogue Inputs: 4 x differential stereo inputs across  
1 x 25 way D-Types female

Digital Inputs: 4 x inputs on  
1 x 25 way D-Type female

Analogue Outputs: 4 x inputs on  
1 x 25 way D-Type female

Digital Outputs: 4 x outputs on  
1 x 25 way D-Type female

RS232 Inputs: 4 x RS232 communication lines on  
1 x 25 way D-Type female

RS232 Outputs: 4 x RS232 communication lines on  
1 x 25 way D-Type female

GPI/O: 10 Inputs & 5 outputs on  
1 x 25 pin D-Type female

Standby 1&2 Inputs: 2 x Analogue differential stereo inputs  
2 x Stereo digital inputs  
2 x RS232 Communication line pairs  
on 1 x 25 way D-Type female

Ethernet Port: 10/100Mbps on 1 x RJ45 socket for IP control,  
SNMP and web GUI

Mains Input (AC): 1 x Universal filtered IEC,  
continuously rated 85-264VAC  
@47- 63Hz, max 20W, plus  
1 x 12V 2A DC supply,  
2.5mm socket fused.

Nominal Input (DC): 12V DC

Maximum Operating  
Range (DC): 5.5V to 13.5V DC

Software Undervolt  
Alarm:  $V_{in} < 11V$

or (Dual DC): 2 x 18V-75V 20W max, DC supply,  
2.5mm socket fused.

Nominal Input (DC): 24V to 48V DC

Maximum Operating  
Range (DC): 20V to 60V DC

Software Undervolt  
Alarm:  $V_{in} < 22V$

Fuse Rating (AC): 1 x Anti-surge fuse 2A 20 x 5mm

### Equipment Type

RB-FS42: Audio failover switcher, 4 + 2 inputs

RB-FS42DC: Audio failover switcher, 4 + 2 inputs,  
2 x DC inputs

**Physical Specifications**

Dimensions (Raw): 48cm(W) x 22cm(D) x 4.2cm(H) 1U  
19" (W) x 8.7" (D) x 1.7" (H) 1U

Dimensions (Boxed): 55cm(W) x 28cm(D) x 17cm(H)  
21.7"(W) x 11"(D) x 6.7"

Weight: Nett: 2.1kg Gross: 3.5kg  
Nett: 4.6lb Gross: 7.7lb

\* Note that this product is deeper than standard Redboxes

**Accessories**

RB-RK3: 1U Rear panel rack kit for large Redboxes

## 6 RB-FS82 Audio Failover Switcher, 8 Main I/O, 2 Standby I/O

### Introduction



Fig 6-1: The RB-FS82 Front Panel

The RB-FS82 8 + 2 audio failover switcher is an important tool in many critical areas in telecommunications and broadcast chains. The device has 8 main + 2 standby, stereo analogue audio, AES/EBU digital audio and RS232 connections (both inputs and outputs) and can be configured via Ethernet for two main operational applications:

1. For switching of program sources to a standby destination in the event of a destination failure ('Standbys to outputs'). Typically this would be audio encoders at a program distribution head end (for audio over IP, E1 or other bearer networks), with "N" x programs feeding "N" x encoders. If an encoder fails the audio destined for that encoder gets routed to a standby encoder so ensuring the continuity of audio to network transport.
2. Switching of program sources, including standby sources, to destinations in the event of source failure ('Standbys to inputs'). Typically this would be audio decoders at a transmission site with "N" x programs and "N" x decoders feeding "N" x transmitters. If a decoder fails, the audio from a standby decoder, or other audio source such as an mp3 player, overrides the signal path to the transmitter so ensuring continuity on air.

The RB-FS82 supports any configuration of up to 8 main program signal paths ( $N \leq 8$ ) and there are 2 standby program signal paths, in either mode of operation. Each program path simultaneously switches analogue L/R audio, AES/EBU digital audio and RS232 data. Each of these signals is wired on D-Type connectors on the rear panel.

All signal paths are passive and therefore completely transparent utilising relay based switching. This has the benefit of a "straight wire" topology during normal (alarm free) operation and also during any power outage to the device. An additional benefit of the passive signal path is AES/EBU bit transparency allowing throughput of AES/EBU AC3 Dolby E™ signals.

To ensure the passive nature of the device, switching is determined by alarm (General Purpose) inputs, with this alarm signalling in turn being normally provided by the encoder or decoders (or other devices) at site. Recognising the mission critical nature of the system, a high grade of relay is used in the RB-FS82.

The passive design ensures continuity of audio in the event of any power outage. However the RB-FS82 also includes dual redundant power supplies (85V-264V AC with a 12V 2A DC backup as standard). The RB-FS82-DC model accepts two DC power inputs (24 - 48V DC) via locking 2.5mm pin power connectors and both power supplies are monitored by the unit. This means that if either power supply fails, the other is ready to take over. In the extremely unlikely event that both fail, the unit's passive signal path ensures a straight wire connection for all 8 program feeds (analogue, AES/EBU & RS232). This is essential for applications such as installation at transmitter sites, where a power failure to the unit will not prevent the audio input signal from being output to each of the supported 8 transmitters.

A row of LEDs on the front panel confirm the unit status, with each individual program path indicated as being in alarm with either Standby 1 or Standby 2 programs clearly confirmed as actively over-riding the failed signal. Alarm LEDs on the front panel are also indicated for power supply 1 failure and power supply 2 failure and these are mirrored by the device's own General Purpose Outputs so facilitating easy interfacing of the device with the addition of a summary alarm status GPO.

By monitoring and acting on a GPI Alarm pin for each signal path the unit can switch between: Through, Standby 1, Standby2 or Silence. The unit will always attempt to route a Standby path when a Main path alarm is detected and if both Standby paths are already in use, then one of the two remaining options (Through, Silence) will be used. The unit can be configured to either Automatically restore a Main 'through' path or wait for a Manual button press.

In the event of alarm clearing, the unit will automatically revert to normal operation, but a manual reversion mode is also provided, allowing for engineering investigation without the unit 'hunting' between different signal paths. Two buttons on the front panel, RESTORE 1 and RESTORE 2, allow manual restoration of the previously failed signal paths, away from Standby 1 and Standby 2 respectively.

To facilitate integration with site management systems the RB-FS82 supports SNMP V1 and is configured by a simple web based GUI. All relevant information regarding input/output status, alarms and power supplies is available via SNMP GET requests to the unit. Traps can also be generated for most of the actions which can occur, including power supply fail and input GPI alarms, etc.

Contact Sonifex for further information if you have a particular requirement that isn't catered for by the RB-FS82 as standard.

**Category:** Synchronisers, Delays & Silence Detectors.

**Product Function:** To route the source audio signals to a standby encoder in event of encoder fail. Or to route the destination audio signals from a standby decoder in event of decoder fail.

**Typical Applications:** As a failover switcher for multi channel audio transport over E1 or IP, typically as performed by APT Oslo, Prodyss Nureus, where a N+1 topology is adopted.

**Features:**

- Relay based switching.
- Dual DC, or AC, power supplies (select when ordering).
- Encoder site (Set via IP): 8 stereo program inputs, 8 + 2 stereo program outputs where each program input/Output carries: analogue L/R, stereo AES/EBU & RS232.
- Encoder site: Each program output has an alarm detect GP input.
- Decoder Site (Set via IP): 8 +2 stereo program inputs, 8 program outputs where each program input carries: analogue L/R, stereo AES/EBU & RS232.
- Decoder Site: Each program input has an alarm detect GP input.
- AES/EBU transparent (for Dolby E transport).
- Passive throughput in event of power outage.
- GPO output for signalling RB-FS82 alarm conditions: PSU 1/2 fail, Standby 1/2 active, Summary Alarm.
- Automatic or Manual reversion modes.
- LED indicators on front panel.
- IP control, including Web GUI and SNMP.

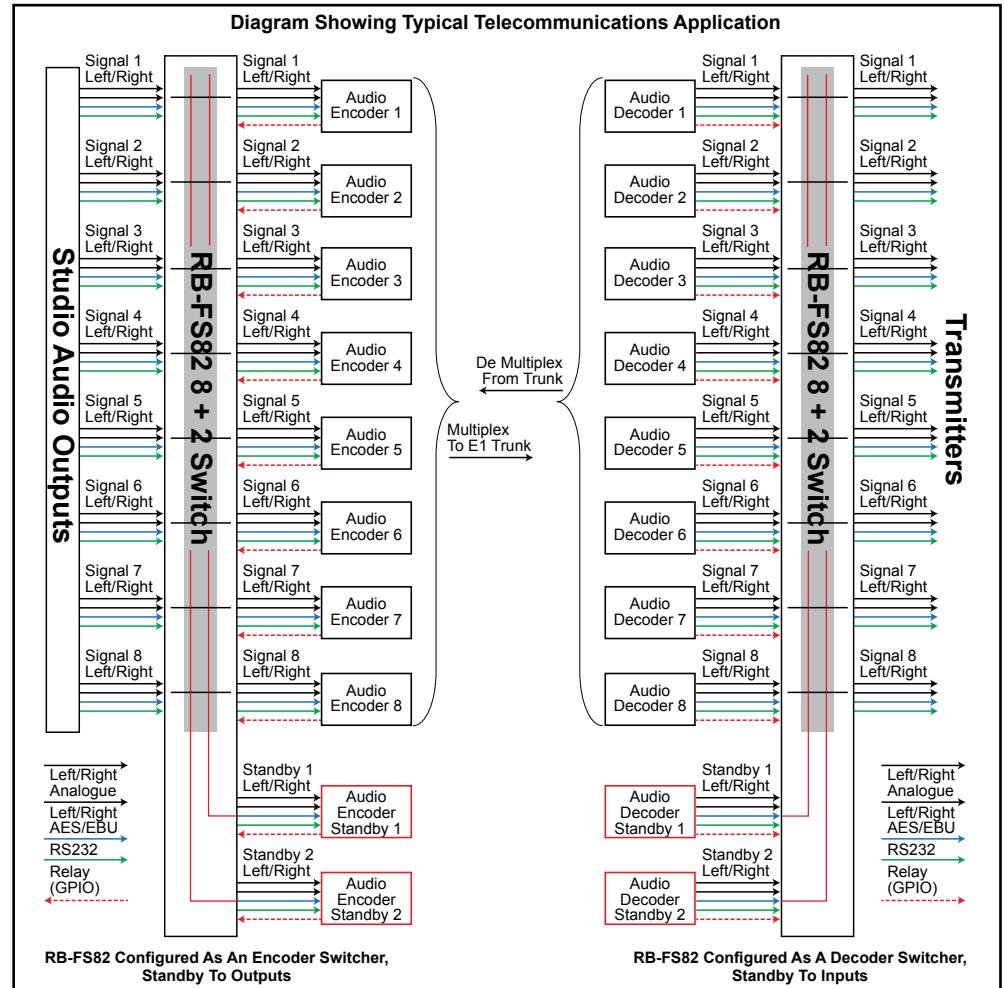

Fig 6-2: The RB-FS82 Diagram

## Connections & Operation

### Front Panel

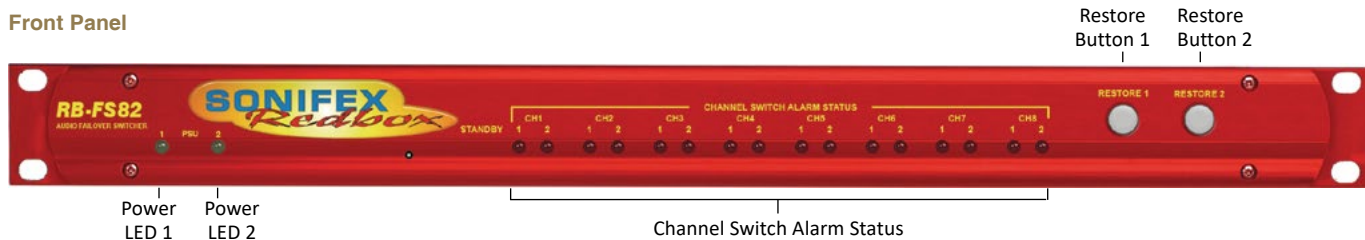

Fig 6-3: The RB-FS82 Front Panel

The front panel consists of 18 LED indicators, two lit RESTORE buttons and a recessed reset switch. The left-most pair of green LEDs are PSU indicators. Next there is a pair of red LEDs for each Main channel. The two RESTORE buttons on the right end of the panel are lit by bi-colour red/green LEDs.

The behaviour of each indicator is as follows:

#### PSU1 and PSU2

These LEDs will be on solid green when there is a valid power supply connected to the respective input on the rear panel. The LED will be off when no power is detected. The LED will flash if power is detected but the voltage is too low.

#### Channel LED 1 and 2

Each LED corresponds to the activity of the respective Standby signal (1 or 2). When both LEDs are off, the Main channel in question is routing "Through". The first LED will light if the Main channel in question is routing Standby 1 path. Conversely the second LED will light if the Main channel is routing Standby 2 path. Both LEDs will flash for a channel that is routing "Silence" or routing "Through" whilst the input is Alarmed.

#### Restore Button LEDs

Solid green indicates that the respective Standby channel is not Alarmed and is not being used. Solid red occurs when the respective Standby channel is in an Alarmed state. Solid orange signifies that the respective Standby signal is being routed to a Main channel which is in an Alarmed state. Flashing orange indicates that the respective Standby signal is being routed to a Main channel which is no longer in an Alarmed state and is ready to be restored. This flashing orange state will only occur if the Main channel in question is not set to Auto Restore.

#### Restore Buttons

##### STANDBY RESTORE

The restore buttons can be used to perform several functions. As described above they are used to restore Main channels from Standby when those channels are configured in manual mode.

### **GLOBAL RESTORE**

You can also modify the Global Restore option by using the right-most button (RESTORE 2). Pressing and holding this button will cause the LEDs to cycle through three different indications; Double Orange, Double Red then Double Green. Each Indication corresponds to a different setting of the Global Restore option. Whilst the buttons are indicating the option you desire, let go of the RESTORE 2 button to set the Global Restore option:

- Double Orange is Global Auto Restore. Global Automatic sets all channels to auto restore, useful as a quick method of restoring multiple channels.
- Double Red is Global Manual. Global Manual, sets all channels to manual restore, which can be useful for fault finding etc.
- Double Green is Global GUI configuration. Global GUI sets each channel restore option back to that which has been configured using the web based GUI.

### **Factory Reset**

The two RESTORE buttons can also be used for two special reset cases. Holding RESTORE 1 while the unit is power cycled or reset, will cause the unit configuration to be reset to factory defaults. All options are reset to defaults including any network settings that have been modified. The PSU Status LEDs will flash when the unit reboots to indicate that the factory reset has taken place.

### **Boot Mode**

Holding both RESTORE buttons while the unit is power cycled or reset, will cause the unit to revert to Bootstrap Mode.

**Warning:** This removes the main firmware from the unit and should not be necessary unless the unit has been loaded with incorrect or corrupted firmware. Once in Bootstrap Mode you will need to load correct main firmware back into the unit using the web based GUI as normal.

## Rear Panel Connections



Fig 6-4: The RB-FS82 Rear Panel

The back panel consists of 10 x 25 way D-Type sockets, an Ethernet port and power inlets.

### Ethernet Port

The Ethernet port is a standard RJ-45 connector on the rear panel. It is a 10/100Mbps link and has green and amber indicators for link status and speed selection. The unit can be controlled remotely over the Ethernet connection using the built-in webserver. By default the unit is configured for dynamic addressing using DHCP.

The connections for the RJ45 connector are as follows:

Ethernet Connector (RJ-45)			
Pin No.	Function	Pin No.	Function
Pin 1	Transmit data (+)	Pin 5	No connection
Pin 2	Transmit data (-)	Pin 6	Receive data (-)
Pin 3	Receive data (+)	Pin 7	No connection
Pin 4	No connection	Pin 8	No connection

### AC Power Input

The AC power is applied via a standard three-pin IEC male socket. Mains voltages between 85V and 264V AC and frequencies between 47 and 63Hz are accepted without adjustment.

A 2A, 5 x 20mm SB fuse is used. The Earth pin MUST be connected to ensure safety.

### DC Power Input

The DC power is applied via a locking 2.5mm power socket 1 x 12V 2A DC supply,

### Analogue, AES/EBU Digital & RS232 Input & Outputs

The top row of D-Types take the input signals and from left to right correspond to; Analogue Channels 1 – 4, Analogue Channels 5 – 8, Digital Channels 1 – 8 and Standby Channels 1 and 2 for each signal type.

The first four bottom D-Types from left to right supply the output signals for the corresponding inputs above them.

See the 'D-Type Connection Details' section for specific connection details for each connector.

## 25 Way D-Type Connection Details

The following table gives the pin out for the main analogue, digital and RS232 input and output channels, according to standard D-Type pin ordering.

Pin No	Analogue 1 Signals (Channels 1 - 4)	Analogue 2 Signals (Channels 5 - 8)	AES/EBU Digital Signals	RS232 Signals
Pin 1	Ch1 L - Phase	Ch5 L - Phase	Ch1 - Phase	Ch1 - TXD
Pin 14	Ch1 L - Non-Phase	Ch5 L - Non-Phase	Ch1 - Non-Phase	Ch1 - RXD
Pin 2	Screen	Screen	Screen	Screen
Pin 15	Ch1 R - Phase	Ch5 R - Phase	Ch2 - Phase	Ch2 - TXD
Pin 3	Ch1 R - Non-Phase	Ch5 R - Non-Phase	Ch2 - Non-Phase	Ch2 - RXD
Pin 16	Screen	Screen	Screen	Screen
Pin 4	Ch2 L - Phase	Ch6 L - Phase	Ch3 - Phase	Ch3 - TXD
Pin 17	Ch2 L - Non-Phase	Ch6 L - Non-Phase	Ch3 - Non-Phase	Ch3 - RXD
Pin 5	Screen	Screen	Screen	Screen
Pin 18	Ch2 R - Phase	Ch6 R - Phase	Ch4 - Phase	Ch4 - TXD
Pin 6	Ch2 R - Non-Phase	Ch6 R - Non-Phase	Ch4 - Non-Phase	Ch4 - RXD
Pin 19	Screen	Screen	Screen	Screen
Pin 7	Ch3 L - Phase	Ch7 L - Phase	Ch5 - Phase	Ch5 - TXD
Pin 20	Ch3 L - Non-Phase	Ch7 L - Non-Phase	Ch5 - Non-Phase	Ch5 - RXD
Pin 8	Screen	Screen	Screen	Screen
Pin 21	Ch3 R - Phase	Ch7 R - Phase	Ch6 - Phase	Ch6 - TXD
Pin 9	Ch3 R - Non-Phase	Ch7 R - Non-Phase	Ch6 - Non-Phase	Ch6 - RXD
Pin 22	Screen	Screen	Screen	Screen
Pin 10	Ch4 L - Phase	Ch8 L - Phase	Ch7 - Phase	Ch7 - TXD
Pin 23	Ch4 L - Non-Phase	Ch8 L - Non-Phase	Ch7 - Non-Phase	Ch7 - RXD
Pin 11	Screen	Screen	Screen	Screen
Pin 24	Ch4 R - Phase	Ch8 R - Phase	Ch8 - Phase	Ch8 - TXD
Pin 12	Ch4 R - Non-Phase	Ch8 R - Non-Phase	Ch8 - Non-Phase	Ch8 - RXD
Pin 25	Screen	Screen	Screen	Screen
Pin 13	N/C	N/C	N/C	N/C

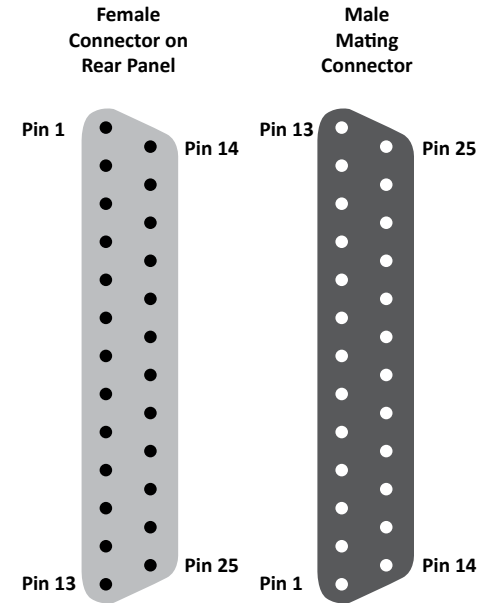

Fig 6-5: The RB-FS82 Female and Male Connectors

### GPIO Connector

The last D-Type on the bottom of the rear panel is the GPIO connector and is the location of the 10 GPI Alarm pins corresponding to each of the input signal paths. The 10 pins for the closing contact alarms generated by the RB-FS82 are also here, along with ground reference pins to facilitate the operation of the GPIs in active low mode.

Pin No.	Signal	I/O	Description
Pin 1	GPO1-1	O	Closing Contact Alarm 1
Pin 14	GPO1-2	O	Closing Contact Alarm 2
Pin 2	GPO2-1	O	Closing Contact Alarm 3
Pin 15	GPO2-2	O	Closing Contact Alarm 4
Pin 3	GPO3-1	O	Closing Contact Alarm 5
Pin 16	GPO3-2	O	Closing Contact Alarm 6
Pin 4	GPO4-1	O	Closing Contact Alarm 7
Pin 17	GPO4-2	O	Closing Contact Alarm 8
Pin 5	GPO5-1	O	Closing Contact Alarm 9
Pin 18	GPO5-2	O	Closing Contact Alarm 10
Pin 6	GPI-1	I	General Purpose Input 1 - Alarm Signal
Pin 19	GPI-2	I	General Purpose Input 2 - Alarm Signal
Pin 7	GPI-3	I	General Purpose Input 3 - Alarm Signal
Pin 20	GPI-4	I	General Purpose Input 4 - Alarm Signal
Pin 8	GPI-5	I	General Purpose Input 5 - Alarm Signal
Pin 21	GPI-6	I	General Purpose Input 6 - Alarm Signal
Pin 9	GPI-7	I	General Purpose Input 7 - Alarm Signal
Pin 22	GPI-8	I	General Purpose Input 8 - Alarm Signal
Pin 10	GPI-9	I	General Purpose Input 9 - Alarm Signal
Pin 23	GPI-10	I	General Purpose Input 10 - Alarm Signal
Pin 11	N/C	-	
Pin 24	N/C	-	
Pin 12	DGND	-	Ground Return for External Circuits
Pin 25	DGND	-	Ground Return for External Circuits
Pin 13	DGND	-	Ground Return for External Circuits

### Standby 1 - 2 Connector

The following table gives the connections for the Standby Channel connectors.

Pin No.	Type	Signal
Pin 1	Standby 1 RS232	SB1-TXD
Pin 14	Standby 1 RS232	SB1-RXD
Pin 2	Screen	SCREEN
Pin 15	Standby 2 RS232	SB2-TXD
Pin 3	Standby 2 RS232	SB2-RXD
Pin 16	Screen	SCREEN
Pin 4	Standby 1 AES/EBU Phase	SB1 Digital P
Pin 17	Standby 1 AES/EBU Non-Phase	SB1 Digital NP
Pin 5	Screen	SCREEN
Pin 18	Standby 2 AES/EBU Phase	SB2 Digital P
Pin 6	Standby 2 AES/EBU Non-Phase	SB2 Digital NP
Pin 19	Screen	SCREEN
Pin 7	Standby 1 Analogue Left Phase	SB1 Left P
Pin 20	Standby 1 Analogue Left Non-Phase	SB1 Left NP
Pin 8	Screen	SCREEN
Pin 21	Standby 1 Analogue Right Phase	SB1 Right P
Pin 9	Standby 1 Analogue Right Non-Phase	SB1 Right NP
Pin 22	Screen	SCREEN
Pin 10	Standby 2 Analogue Left Phase	SB2 Left P
Pin 23	Standby 2 Analogue Left Non-Phase	SB2 Left NP
Pin 11	Screen	SCREEN
Pin 24	Standby 2 Analogue Right Phase	SB2 Right P
Pin 12	Standby 2 Analogue Right Non-Phase	SB2 Right NP
Pin 25	Screen	SCREEN
Pin 13	-	N/C

## Typical Application

The primary application of the RB-FS82 is to monitor the status of 8 main signal groups and, in the event of an alarm status, route one of 2 standby signal groups accordingly. The statuses of both the 8 main signal groups and the 2 standby groups are monitored via GPI pins located on the rear of the unit. In this example, the term 'passive through' refers to the input being routed to the output directly.

Imagine you have your 8 main signal groups from decoders, for example, connected through the RB-FS82 to encoders. You would also have up to 2 standby signal groups connected to the standby inputs on the rear of the RB-FS82 and each decoder status would be relayed to the RB-FS82 using the GPI connections on the rear of the unit.

Whilst each decoder is working as expected, all GPI pins are inactive and the RB-FS82 is passively routing all of the decoded signal groups to the encoders connected at its outputs. All of the red indicators on the front panel are off and the two RESTORE buttons are illuminated green to show that they are not in use.

### Failure Detection

When a problem occurs with decoder 6, for example, it activates the relevant GPI pin to alarm main signal group 6. The RB-FS82 immediately switches standby group 1 to main signal group 6 output. The corresponding red standby indicator illuminates for group 6 on the front panel of the RBFS82.

Also the RESTORE 1 button becomes illuminated orange to indicate that standby signal group 1 is in use.

Now imagine that decoder 4 were to fail as well. The RB-FS82 senses the alarm GPI status and immediately switches standby signal group 2 to main signal group 4 output. Again, the corresponding red standby indicator illuminates for group 4 on the front panel of the RB-FS82 and the RESTORE

2 button becomes illuminated orange to indicate that standby signal group 2 is in use.

If any more decoders were to signal an alarm status, the RB-FS82 would be unable to switch the output in question to a standby signal group, as both are already in use. In this case you may configure the behaviour in one of two ways; the RB-FS82 can either continue to route through the signal group despite the alarmed state, or the RB-FS82 can break the signal paths and route "silence" instead. In either case, both of the red front panel indicators flash simultaneously to indicate that a signal source is alarmed and is not routing a standby signal group.

### Setting a Priority Signal Input

There is a Priority feature which can be configured for any one of the 8 main signal groups. Following the example above, if main signal group 1 were defined as the priority and it was to become alarmed (whilst both standby signal groups were already being used by main groups 6 and 4), then the most recently routed standby signal group, in this case standby 2, would be "stolen" by signal group 1 and main signal group 4 would route either "silence" or passive through.

### Restoring Signals

Now let's say that decoder 4 begins functioning normally and removes its alarm status. If signal group 4 is configured to Automatic Restore mode, the RB-FS82 immediately switches the signal path back to passive through, if it was not already in this state. The red front panel indicators for signal group 4 both turn off to indicate that there is no longer an alarm condition.

If signal groups 6 and 1 are both configured as Manual Restore mode, when their respective alarm conditions are lifted the RB-FS82 indicates that each channel can now be restored by flashing the relevant RESTORE button orange. Pressing the RESTORE button turns off the red front panel indicators for the relevant signal group and also illuminates the RESTORE button green to show that this standby signal group is no longer in use.

## GPI Operation

There are GPI pins to sense the status of the 2 standby signal groups as well. If the status of a standby group becomes alarmed whilst it is being routed to one of the 8 main signal outputs, then the main signal output switches to its routing preference, either silence or passive through. This is equivalent to having the standby signal stolen by a higher priority main signal group.

## Power Supply Monitoring

The RB-FS82 monitors each power supply connection and displays a status and an approximate voltage reading for both on the webpage. When a power supply is operating at an acceptable level the front panel green indicator will be on solidly. If though a 12V battery pack was connected to the DC input which was in a state of discharge, it may only produce 10.5V - anything below 11V is seen by the RB-FS82 as a fault. In this case the green front panel indicator flashes to indicate this and any associated enabled alarms or SNMP traps are also generated.

## Alarm Output Relays & SNMP

There are 5 closing contact relays present on the rear panel GPIO connector. These are used to create alarms from the RB-FS82 in various circumstances. There is an alarm for the validity of each power supply, one to show the usage state of each standby signal group and a summary alarm, which is active whenever any other alarm is present.

In addition to these physical alarm signals the RB-FS82 can generate SNMP Traps upon most actions: PSU failure, PSU return, Standby activation/deactivation and any change to a main signal group routing. The current status of all main and standby signal group inputs and outputs, along with power supply states and levels can be read back by a Network Management System (NMS) using SNMP Get functionality.

The configuration of the options and alarms mentioned above is performed via the built in web browser based GUI.

## Network Discovery & Webserver Configuration

In addition to any physical controls the RB-FS82 has a built in webserver which can allow you to control and configure the unit remotely through a web browser. The webpage interface also enables you to view status information, alter network settings, and update product firmware.

The RB-FS82 network interface employs Zeroconf networking, meaning that it supports DHCP, AutoIP and MDNS-SD using Bonjour. We provide a free application available for download from our website ([www.sonifex.co.uk/technical/software](http://www.sonifex.co.uk/technical/software)), to facilitate the discovery and use of Sonifex network enabled hardware, see below for more information.

### Connecting to the Unit:

Connecting to the webpage interface is as simple as typing the IP address of the unit into the address bar of a web browser on a PC connected to the same network.

### DHCP

The RB-FS82 will have DHCP and AutoIP enabled by default, if your network has a DHCP server then the unit will be assigned an IP address which can be found easily by using the Sonifex service discovery application, or by contacting your network administrator. The nature of DHCP means that the unit is not guaranteed to maintain a fixed IP address each time it is reconnected to the network. See the section on static network settings below for information on how to fix the IP address of the unit.

### AutoIP

If your network does not support DHCP or it is disabled, then with AutoIP enabled the unit will assign itself an IP address from the AutoIP range (169.254.1.0 to 169.254.254.255). Once an AutoIP address has been assigned you will need to connect the unit directly to a PC using an Ethernet cable. Ensure that the PC has dynamic addressing enabled and you will be able to use the Sonifex discovery application on this mini network to access the webpage interface.

### Static Network Settings

Accessing the webpage interface allows you to configure the network settings as you like. To give the unit a fixed network address, enter appropriate static details and disable both DHCP and AutoIP. The unit will now apply the static network settings whenever it is connected to a network.

### MDNS-SD and Bonjour

Bonjour is a hardware discovery service developed by Apple and as such it is natively supported by Apple devices and operating systems. Bonjour for Windows is available, go to our website ([www.sonifex.co.uk/technical/software](http://www.sonifex.co.uk/technical/software)) or other download stores and download the appropriate version for your operating system.

On a Bonjour enabled device or system, you can connect to a unit using only its hostname. By default the hostname for the RB-FS82 will be the hardware ID appended by the unique serial number of the unit:

**[Hardware ID] – [Serial No.]**

**RB-FS82-654321**

To connect to a unit using Bonjour you can simply discover and launch the webpage interface from the Sonifex service discovery application. Alternatively you can simply type the hostname appended by the local domain name into the address bar of your web browser, for the example above you would enter the following:

**RB-FS82-654321.local.**

The hostname is independent of the IP address and this means that the unit can always be discovered and accessed in this way, regardless of which IP address it has been assigned by a DHCP server. The hostname can be changed to make it more memorable or descriptive of an implementation, however, conflicting names should be avoided.

### Sonifex Service Discovery App

This is a free download for Windows, available from our website ([www.sonifex.co.uk/technical/software](http://www.sonifex.co.uk/technical/software)). This application uses Bonjour to locate networked hardware and discover what services it has to offer. On a device or system running Bonjour you can discover Sonifex hardware and launch the webserver interface if available. The application also offers legacy discovery for systems which do not support Bonjour or for Sonifex hardware which is not running MDNS-SD.

The web based GUI has a menu bar that allows you to navigate through various pages to configure different aspects of the unit. Each page follows the same standard layout as the Home page, with current status/configuration settings on the left and tooltip explanations in the box on the right. The page footer contains contact details for Sonifex LTD. A brief overview of each page follows:

**Home:** This page allows you to view the current status of the input/output ports and the power supplies. The page automatically updates to show current data from the unit.

**Device Info:** This page useful information about the unit you are connected such as the Version Number, Serial Number, MAC Address and active Network Address.

**Network:** This page allows you to change the network settings of the unit.

**SNMP:** This page allows you to change the community string for this unit. You can also configure, enable / disable, up to 3 SNMP trap destinations, which will receive any SNMP traps generated by the RB-FS82 as it functions.

**Channels:** This page allows you to configure various settings for each of the 10 channels (8 Main and 2 Standby). At the top there are two global settings, Global Restore, which is described previously, and Priority. The Priority setting allows the implementation to favour one channel above all others. This basically means that in the event of the Priority channel becoming Alarmed whilst both Standby channels are already in use, the

Priority channel will “steal” a Standby channel from one of the other, lower priority channels.

For each of the 8 Main channels you can specify whether the path should Auto restore or not, and you can pick the routing preference for when no Standby is available. There is the option to select whether you want the GPI alarm pin to be active high or active low for each channel. You can also enable and disable various SNMP traps relating to each channel here. For the standby channels there are more SNMP trap enable/disable options.

**Power:** This page allows you to enable/disable various SNMP traps relating to PSU1 and PSU2.

**GPO:** This page lets you mask/unmask the Alarms (closing contacts) generated from the FS82. Useful, for example, if you are only going to be using PSU1 you can prevent the PSU2 alarm from activating.

**LEDs:** This page simply lets you control the relative brightness of the LEDs on the front panel, in graduated steps from 1 – 5, with 5 being the brightest.

**Update:** This page allows you to load new firmware into the unit. Simply browse to the location of the correct .dwn file and click update.

**Reset to Defaults:** This is a button which restores the majority of the units settings to default values.

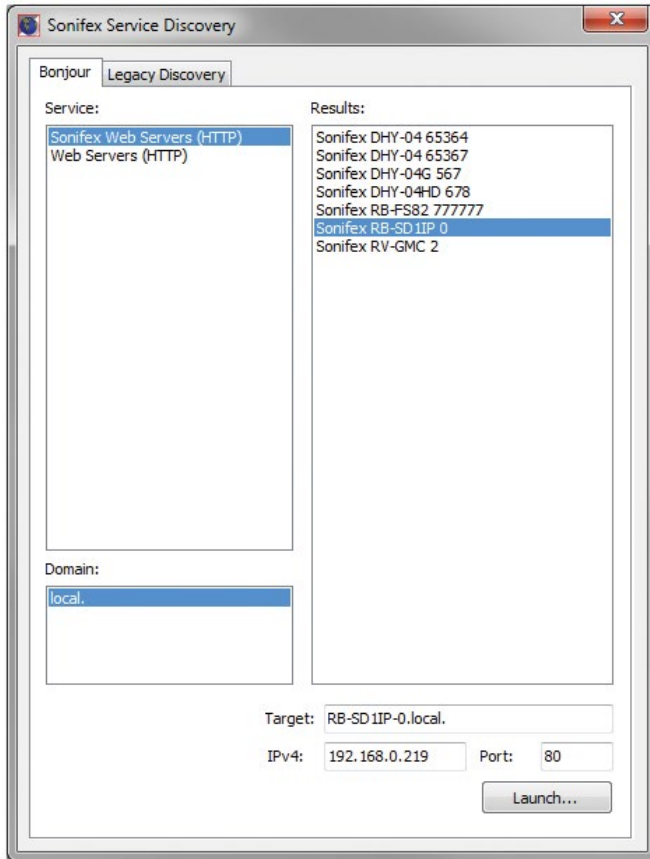

Fig 6-6: The RB-FS82 Bonjour Panel

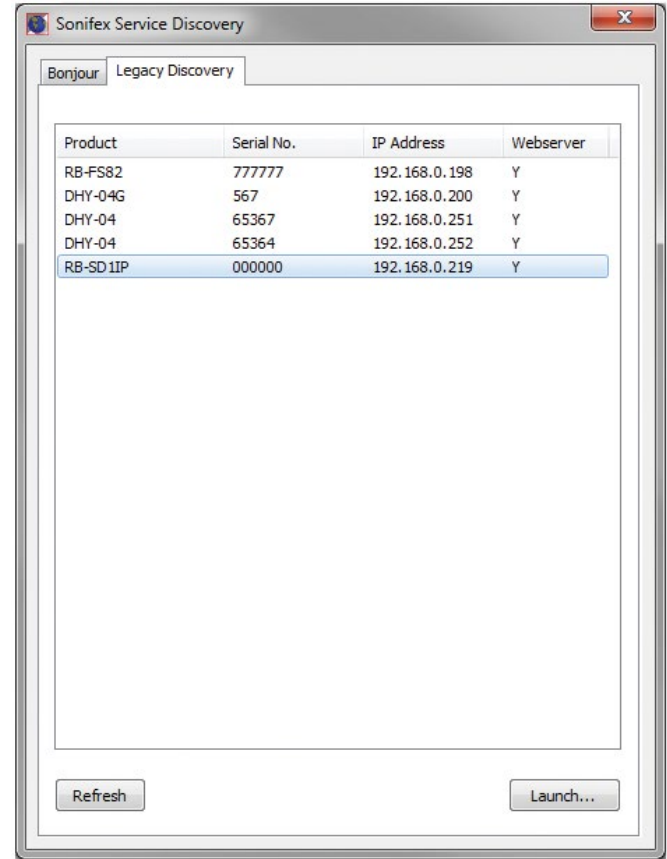

Fig 6-7: The RB-FS82 Legacy Discovery Panel

## Device Info

**SONIFEX**  
Manufacturers of audio & video  
equipment for radio & TV studios

**RB-FS82**

Home | Device Info | Network | Configuration | Update | Set to Defaults

**DEVICE**

Device: RB-FS82  
Serial Number: 777777  
Description: Redbox Failover Switch 8 Main, 2 Standby  
Firmware Version: V1.03

**NETWORK**

Host Name: RB-FS82-777777  
Active IP Address: 192.168.0.220  
Active Netmask: 255.255.255.0  
Active Gateway: 192.168.0.149  
MAC Address: 00:50:C2:05:A9:BE

**Device Information**  
This page shows general information about the connected RB-FS82.

Sonifex Ltd, 61 Station Road, Irthlingborough, Northants, NN9 5QE, UK. Tel: +44 (0)1933 650700 Fax: +44 (0)1933 650728 Email: [sales@sonifex.co.uk](mailto:sales@sonifex.co.uk)

**Device Info:** This page useful information about the unit you are connected such as the Version Number, Serial Number, MAC Address and active Network Address.

Fig 6-8: The RB-FS82 Device Info Panel

## Home Page

**SONIFEX**  
Manufacturers of audio & video equipment for radio & TV studios

**RB-FS82**

Home | Device Info | Network | **Configuration** | Update | Set to Defaults

**HOME**

**Input Status:**

1	2	3	4	5	6	7	8	S1	S2
Red	Green	Green	Red	Green	Green	Green	Green	I	II

**Output Status:**

1	2	3	4	5	6	7	8
I	Green	Green	II	Green	Green	Green	Green

**PSU 1**      **PSU 2**

**PSU Status:**           

**PSU Voltage:**      12.0V      12.7V

**Home Page**

**Input Status**  
The current status of the 8 main input channels and each of the 2 standby channels. Green indicates a valid signal and red indicates an invalid signal.

**Output Status**  
The current status of the 8 output channels. Green indicates a valid signal, red indicates an invalid signal and grey indicates that the channel is routing silence. If the channel is routing a standby signal, the standby channel number will appear inside the indicator.

**NOTE:** The Status for standby 1 and 2 are labelled "I" and "II" respectively. This is to allow clear indication of when a specific channel is routing a standby signal.

**Power Supply Status**  
The current status and an approximate voltage of each power supply are shown here. Red indicates that the voltage supplied is not within the acceptable range.

Sonifex Ltd, 61 Station Road, Litchingborough, Northants, NN19 5QE, UK. Tel: +44 (0)1933 650700 Fax: +44 (0)1933 650726 Email: [sales@sonifex.co.uk](mailto:sales@sonifex.co.uk)

Fig 6-9: The RB-FS82 Home Screen

**Input Status**

The current status of the 8 main input channels and each of the 2 standby channels. Green indicates a valid signal and red indicates an invalid signal.

**Output Status**

The current status of the 8 output channels. Green indicates a valid signal, red indicates an invalid signal and grey indicates that the channel is routing silence. If the channel is routing a standby signal, the standby channel number will appear inside the indicator.

**Note:** The Status for standby 1 and 2 are labelled "I" and "II" respectively. This is to allow clear indication of when a specific channel is routing a standby signal.

**Power Supply Status**

The current status and an approximate voltage of each power supply are shown here. Red indicates that the voltage supplied is not within the acceptable range.

## Network Settings

**SONIFEX**  
Manufacturers of audio & video  
equipment for radio & TV studios

**RB-FS82**

Home | Device Info | Network | Configuration | Update | Set to Defaults

### NETWORK SETTINGS

**Host Name:**

**IP Address:**

**Netmask:**

**Gateway:**

**DHCP:**  
 Enable  
 Disable

**Auto IP:**  
 Enable  
 Disable

**Network Settings**

**Host Name**  
The Host Name for this unit is used for Multicast DNS Service Discovery. The default Host Name is the unit Hardware Type, appended with the unique Serial Number.

**IP Address**  
Please enter the static IP Address that you wish to assign to this unit. The address must be in the correct form and the default address is: 192.168.0.100

**Netmask**  
Please enter the Netmask of the network you wish to connect to. The default subnet mask is: 255.255.255.0

**Gateway**  
Please enter the Gateway Address of your router. The default gateway address is: 192.168.0.149

**DHCP**  
Disable to prevent the unit from requesting a dynamic address from a DHCP server.

**Auto IP**  
Disable to prevent the unit from assigning itself an address from the Auto IP range.

**NOTE:** With both DHCP and Auto IP disabled the unit will use the static network settings entered here.

Sonifex Ltd. 61 Station Road, Irthlingborough, Northants, NN19 5QE, UK. Tel: +44 (0)1933 650700 Fax: +44 (0)1933 650726 Email: [sales@sonifex.co.uk](mailto:sales@sonifex.co.uk)

Fig 6-10: The RB-FS82 Network Settings Screen

### Host Name

The Host Name for this unit is used for Multicast DNS Service Discovery. The default Host Name is the unit Hardware Type, appended with the unique Serial Number.

### IP Address

Please enter the static IP Address that you wish to assign to this unit. The address must be in the correct form and the default address is: 192.168.0.100

### Netmask

Please enter the Netmask of the network you wish to connect to. The default subnet mask is: 255.255.255.0

### Gateway

Please enter the Gateway Address of your router. The default gateway address is: 192.168.0.149

### DHCP

Disable to prevent the unit from requesting a dynamic address from a DHCP server.

### Auto IP

Disable to prevent the unit from assigning itself an address from the Auto IP range.

**Note:** With both DHCP and Auto IP disabled the unit will use the network settings entered above.

## SNMP

**SONIFEX**  
Manufacturers of audio & video equipment for radio & TV studios

**RB-FS82**

Home | Device Info | Network | Configuration | Update | Set to Defaults

### SNMP

Community String: public

Destination IP 1: 0.0.0.0  
 Destination IP 2: 0.0.0.0  
 Destination IP 3: 0.0.0.0

Destination 1:  Enabled  
 Disabled

Destination 2:  Enabled  
 Disabled

Destination 3:  Enabled  
 Disabled

---

**SNMP**  
The community string may be up to 20 characters long.

**Trap Destination IP Addresses**  
You can set up to 3 different IP addresses which will receive all traps generated by the RB-FS82. Each destination can be enabled or disabled individually.

**NOTE:** The default community string is "public". It is recommended that you change this to make it harder to guess, or descriptive of the implementation. However, SNMP Version 1 community strings are not secure - they are sent as raw bytes over the network, i.e. there is no encryption.

Sonifex Ltd. 61 Station Road, Sittingborough, Northants, NN9 5QE, UK. Tel: +44 (0)1933 650700 Fax: +44 (0)1933 650726 Email: [sales@sonifex.co.uk](mailto:sales@sonifex.co.uk)

Fig 6-11: The RB-FS82 SNMP Screen

**Community String**

The community string may be up to 20 characters long.

**Trap Destination IP Addresses**

You can set up to 3 different IP addresses which will receive all traps generated by the RB-FS82. Each destination can be enabled or disabled individually.

**Note:** The default community string is “public”. It is recommended that you change this to make it harder to guess, or descriptive of the implementation. However, SNMP Version 1 community strings are not secure - they are sent as raw bytes over the network, i.e. there is no encryption.

## Channel Settings

**CHANNELS**

Global Restore: Per Channel

Priority: None

Select Channel: 1

Status Trap:  Enable  Disable

Restore:  Auto  Manual

Route Pref:  Through  Silence

GPI Alarm:  Active Low  Active High

**Channel Settings**  
Select each Channel you wish to configure from the drop down list and change the settings as required. You may configure all channels before submitting.

**Global Restore**  
You can choose to use restore options as configured for each individual channel (Per Channel), or set global Auto/Manual. Note that this setting can also be controlled physically from the front panel of the unit.

**Priority**  
One of the 8 main channels can be set as a priority route for a standby signal. This priority channel will "steal" a standby signal, if necessary, from another channel when it detects a failure.

**Status / Active / Inactive - Trap**  
Enable or disable the SNMP Trap generated when the output status of a channel changes. There are also Traps to indicate when a standby signal is in use (Active) or not (Inactive).

**Restore**  
The RB-FS82 can either automatically restore a channel from standby when the signal comes up, or wait for the user to manually restore the signal path.

**Route Preference**  
When alarmed, the first routing preference is always a standby channel. If no standby signal is available, the unit can either pass through the original signal or route silence.

**GPI Alarm**  
Each of the 10 Channel Alarm GPI pins can be Active Low (alarmed when pulled to ground) or Active High (alarmed when left open).

Sonifex Ltd, 61 Station Road, Wellingborough, Northants, NN9 5QE, UK. Tel: +44 (0)1933 650700 Fax: +44 (0)1933 650726 Email: [sales@sonifex.co.uk](mailto:sales@sonifex.co.uk)

Fig 6-12: The RB-FS82 Channel Settings Screen

Select each Channel you wish to configure from the drop down list and change its settings as required. Once you have configured all channels, hit submit.

### Global Restore

You can choose to use restore options as configured for each individual channel (Per Channel), or set global Auto/Manual.

**Note:** this setting can also be controlled physically from the front panel of the unit

### Priority

One of the 8 main channels can be set as a priority route for a standby signal. This priority channel will "steal" a standby signal, if necessary, from another channel when it detects a failure.

### Status / Down / Up / Active / Inactive - Trap

Enable or disable the SNMP Trap which is generated when this channel changes output status, goes down or comes back up. There are additional Traps to indicate when a standby signal is active (in use) or inactive (not used).

### Restore

The RB-FS82 can either automatically restore a channel from standby when the signal comes up, or wait for the user to manually restore the signal path.

### Route Preference

When a channel is down, the first routing preference is always a standby channel, if both standby signals are in use by channels with higher priority, the RB-FS82 can either pass through the original signal or route silence.

### GPI Alarm

Each of the 10 Channel Alarm GPI pins can be Active Low (alarmed when pulled to ground) or Active High (alarmed when left open).

## Power Supply Trap Settings

**SONIFEX**  
Manufacturers of audio & video equipment for radio & TV studios

**RB-FS82**

Home | Device Info | Network | Configuration | Update | Set to Defaults

**POWER**

PSU 1 Down Trap:  Enable  
 Disable

PSU 1 Up Trap:  Enable  
 Disable

PSU 2 Down Trap:  Enable  
 Disable

PSU 2 Up Trap:  Enable  
 Disable

**Power Supply Trap Settings**  
Traps  
This page lets you enable or disable SNMP Trap generation for specific events on each power supply. This is useful if you are only using one power supply, as you can prevent the unit from raising an unnecessary alarm with your NMS.

Sonifex Ltd. 61 Station Road, Irlingham, Northants, NN19 5QE, UK. Tel: +44 (0)1933 650700 Fax: +44 (0)1933 650726 Email: [sales@sonifex.co.uk](mailto:sales@sonifex.co.uk)

Fig 6-13: The RB-FS82 Power Supply Trap Settings Screen

### Traps

This page lets you enable or disable SNMP Trap generation for specific events on each power supply. This is useful if you are only using one power supply, as you can prevent the unit from raising an unnecessary alarm with your NMS.

## GPO Settings

**SONIFEX**  
Manufacturers of audio & video  
equipment for radio & TV studios

**RB-FS82**

Home | Device Info | Network | Configuration | Update | Set to Defaults

**GPO**

**PSU 1 Fail:**  Enable  Disable

**PSU 2 Fail:**  Enable  Disable

**Standby 1 Active:**  Enable  Disable

**Standby 2 Active:**  Enable  Disable

**Summary Alarm:**  Enable  Disable

**GPO Settings**  
**GPO Masks**  
There are 5 closing relay contact GPOs on the RB-FS82 and each is used to physically output one of the 5 main alarms from the unit. This page enables you to enable or disable the action of each alarm relay.

Sonifex Ltd. 61 Station Road, Irthlingborough, Northants, NN19 5QE, UK. Tel: +44 (0)1933 650700 Fax: +44 (0)1933 650726 Email: [sales@sonifex.co.uk](mailto:sales@sonifex.co.uk)

Fig 6-14: The RB-FS82 GPO Settings Screen

**GPO Masks**

There are 5 closing relay contact GPOs on the RB-FS82 and each is used to physically output one of the 5 main alarms from the unit. This page enables you to enable or disable the action of each alarm relay.

## LED Settings

**SONIFEX**  
Manufacturers of audio & video  
equipment for radio & TV studios

**RB-FS82**

Home | Device Info | Network | Configuration | Update | Set to Defaults

**LEDs**

Brightness Level: 3

submit

**LED Settings**  
**Brightness**  
This page allows you to select the brightness of the LEDs on the front panel of the RB-FS82. There are 5 options, with option 1 being the least bright.

Sonifex Ltd 61 Station Road, Litchingborough, Northants, NN19 5QE, UK. Tel: +44 (0)1933 650700 Fax: +44 (0)1933 650726 Email: [sales@sonifex.co.uk](mailto:sales@sonifex.co.uk)

Fig 6-15: The RB-FS82 LED Settings Screen

### Brightness

This page allows you to select the brightness of the LEDs on the front panel of the RB-FS82. There are 5 options, with option 1 being the least bright.

## Update



Fig 6-16: The RB-FS82 Update Screen

The current firmware version on this unit is shown at the top of the page. To find out if there is new firmware for your unit, check our website.

If an update is available, download the latest file from our website in the '.DWN' format.

Browse your computer to locate the appropriate firmware file. Once the correct file has been selected, hit submit/update.

**Note:** If updated with incorrect or corrupt firmware it may be necessary to recover the unit from boot mode. See the Handbook for details.

## Technical Specifications RB-FS82

### Audio Specification - Digital

The RB-FS82 uses passive fixed switching relays which don't affect the overall audio performance

### Audio Specification - Analogue

Crosstalk: >86dB

### Front Panel Operational Controls

Manual Switching: Via Restore 1 & Restore 2 push-buttons

### Front Panel Indicators

Power LEDs: 2 x Power indicators

Channel Status LEDs: 16 x Standby status indicators, 2 per channel.

Standby Restore LEDs: 2 x illuminated buttons.

### Rear Panel Connections

Analogue Inputs: 8 x differential stereo inputs across  
2 x 25 way D-Types female

Digital Inputs: 8 x inputs on  
1 x 25 way D-Type female

Analogue Outputs: 8 x inputs on  
1 x 25 way D-Type female

Digital Outputs: 8 x outputs on  
1 x 25 way D-Type female

RS232 Inputs: 8 x RS232 communication lines on  
1 x 25 way D-Type female

RS232 Outputs: 8 x RS232 communication lines on  
1 x 25 way D-Type female

GPI/O: 10 Inputs & 5 outputs on  
1 x 25 pin D-Type female

Standby 1&2 Inputs: 2 x Analogue differential stereo inputs  
2 x Stereo digital inputs  
2 x RS232 Communication line pairs  
on 1 x 25 way D-Type female

Ethernet Port: 10/100Mbps on 1 x RJ45 socket for IP control, SNMP and web GUI

Mains Input (AC): 1 x Universal filtered IEC, continuously rated 85-264VAC @47- 63Hz, max 20W, plus  
1 x 12V 2A DC supply, 2.5mm socket fused.  
12V DC

Nominal Input (DC):  
Maximum Operating Range (DC): 5.5V to 13.5V DC

Software Undervolt Alarm: Vin < 11V

or (Dual DC): 2 x 18V-75V 20W max, DC supply, 2.5mm socket fused.

Nominal Input (DC):  
Maximum Operating Range (DC): 20V to 60V DC

Software Undervolt Alarm: Vin < 22V

Fuse Rating (AC): 1 x Anti-surge fuse 2A 20 x 5mm

### Equipment Type

RB-FS82: Audio failover switcher, 8 + 2 inputs

RB-FS82DC: Audio failover switcher, 8 + 2 inputs, 2 x DC inputs

### Physical Specifications

Dimensions (Raw): 48cm(W) x 22cm(D) x 4.2cm(H) 1U  
19" (W) x 8.7" (D) x 1.7" (H) 1U

Dimensions (Boxed): 55cm(W) x 28cm(D) x 17cm(H)  
21.7"(W) x 11"(D) x 6.7"

Weight: Nett: 2.2kg Gross: 3.6kg  
Nett: 4.8lb Gross: 8.0lb

\* Note that this product is deeper than standard Redboxes

### Accessories

RB-RK3: 1U Rear panel rack kit for large Redboxes

**SONIFEX**

[www.sonifex.co.uk](http://www.sonifex.co.uk)

t:+44 (0)1933 650 700

f:+44 (0)1933 650 726

[sales@sonifex.co.uk](mailto:sales@sonifex.co.uk)