



Redbox RB-VHEDD8
3G/HD/SD-SDI Dolby E
Encoder

Redbox RB-VHDDD8
3G/HD/SD-SDI Dolby
E/Dolby Digital Decoder

User Handbook



RB-VHEDD8 & RB-VHDDD8 USER HANDBOOK



RB-VHEDD8 & RB-VHDDD8 USER HANDBOOK

This handbook is for use with the following product:
Redbox RB-VHEDD8 3G/HD/SD-SDI Dolby E Encoder
Redbox RB-VHDDD8 3G/HD/SD-SDI Dolby E/Dolby Digital Decoder

©Sonifex Ltd, 2015 All Rights Reserved
Revision 1.02, September 2015
Sonifex Ltd, 61, Station Road, Irthlingborough,
Northants, NN9 5QE, England.
Tel: +44 (0)1933 650 700
Fax: +44 (0)1933 650 726
Email: sales@sonifex.co.uk
Website: <http://www.sonifex.co.uk>

Information in this document is subject to change without notice and does not represent a commitment on the part of the vendor. Sonifex Ltd shall not be liable for any loss or damage whatsoever arising from the use of information or any error contained in this manual.

No part of this manual may be reproduced or transmitted in any form or by any means, electronic or mechanical, including photocopying, recording, information storage and retrieval systems, for any purpose other than the purchaser's personal use, without the express written permission of Sonifex Ltd. Unless otherwise noted, all names of companies, products and persons contained herein are part of a completely fictitious adaptation and are designed solely to document the use of Sonifex product.

Made in the UK by **SONIFEX**



Contents	
Warranty	i
Warranty and Liability	i
Unpacking the RB-VHEDD8/RB-VHDDD8	iii
Returning the Warranty Card	iii
Safety Information	iv
Safety of Mains Operated Equipment	iv
Voltage Setting Checks	iv
Fuse Rating	iv
Power Cable and Connection	iv
Ordering the Correct Mains Lead	v
Installation Information	v
Atmosphere	v
Electromagnetic Radiation	v
Fitting Redboxes	v
WEEE & RoHS Directives - Sonifex Statement	vi
RB-VHEDD8 – 3G/HD/SD-SDI Dolby E Encoder	1
RB-VHDDD8 – 3G/HD/SD-SDI Dolby E/Dolby Digital Decoder	2
System Block Diagram (RB-VHDDD8)	3
System Block Diagram (RB-VHEDD8)	3
Front Panel Indicators & Controls	4
Power Led	4
Reset Button	4
Selecting The Main Menu	4
Rear Panel Connections	4
Mains Power	4
Remote Control	4
Metadata	5
Serial Video I/O	6
SDI Input	6
SDI Outputs	6
Ref Loop and Ref In	6
RB-VHEDD8 Audio Connections	6
Digital Audio Inputs	6
Dolby E Output	6
LTC Input	6
Dolby Embedder, Unbalanced Input Grounding	7
RB-VHDDD8 Audio Connections	8
Dolby Output	8
Digital Audio Outputs	8
Remote I/O	8
RB-VHEDD8 Status Screens	9
Video Input Status Screen	9
Dolby E Encoder Status Screen	10
Metadata Status Screen	10
RB-VHDDD8 Status Screens	12
Video Input Status Screen	12
Dolby Decoder Status Screen	12
Metadata Status Screen	13
The Main Menu	15
Decoder Control (RB-VHDDD8)	15
Source	15
Dolby Digital	16
AES Channel Select	16
Stream Select	16



CONTENTS

CONTENTS



CONTENTS

<i>Listening Mode</i>	16
<i>Dynamic Range Control</i>	16
<i>Pro-Logic Decode</i>	16
<i>Dolby E</i>	16
<i>Dialogue Normalization</i>	16
<i>PCM</i>	16
<i>Latency</i>	17
<i>Metadata</i>	17
<i>Pro-Logic Decode</i>	17
<i>PCM Metadata</i>	17
<i>Aux. Channel</i>	17
<i>Output Mode</i>	17
<i>DRC Mode</i>	17
<i>Dolby E Program</i>	17
Encoder Control (RB-VHEDD8)	18
Program Config	18
Encoding Mode	19
Frame Rate	19
Bit Depth	20
Metadata	20
Reversion Mode	21
Metadata Source	21
Encoder Inputs	21
Channel 1\2, 3\4, 5\6, 7\8	21
<i>Use External</i>	21
<i>Channel 1</i>	21
<i>Channel 2</i>	21
Delay Control	21
Mode	22
Adjust	22
Termination	22
<i>Channel 1\2, 3\4, 5\6, 7\8 and Dolby Output</i>	22
SRC/CLK Control	22
<i>CH1\2 SRC, CH3\4 SRC</i>	22
<i>CH5\6 Sync, CH7\8 Sync</i>	23
External Audio (RB-VHDDD8)	23
Source Select	23
Termination	23
<i>Channel 1\2, 3\4, 5\6, 7\8, Dolby Output and Aux</i>	23
Embed	23
SDI Output 1 and 2	24
Group 1, 2, 3 and 4	24
SD 24-Bit	24
Embed	24
<i>Channel 1, 2, 3 and 4 (RB-VHEDD8)</i>	24
<i>Channel 1, 2, 3 and 4 (RB-VHDDD8)</i>	26
VANC Metadata (RB-VHDDD8)	27
Embed	27
Channel Pair	27
Audio Delete	27
SDI Output 1 and 2	27
Group 1, 2, 3 and 4	27
Level Control (RB-VHEDD8)	27
External Inputs	27
De-embedder	28
Level Control (RB-VHDDD8)	28
Decoder Outputs	28
De-embedder	28



Remote Outputs	28
Output 1-8	28
Polarity	28
Action	28
Event (RB-VHEDD8)	28
Event (RB-VHDDD8)	29
System	29
Front Panel Lock	29
Network	29
DHCP	29
Static Settings	30
Status	30
Factory Reset	30
Information	30

SCi 31

RB-VHEDD8 System Screen	32
Disconnect/Connect	32
Update Firmware	32
Status	32
Front Panel Lock	33
Network	33
RB-VHDDD8 System Screen	34
Disconnect/Connect	34
Update Firmware	34
Status	34
Network	35
Embed	36
Audio Groups	36
Audio Group Delete	36
SD 24-Bit	36
Metadata (SMPTE-2020) - RB-VHDDD8 Only	37
Encoder (RB-VHEDD8)	37
Control	37
Metadata Control	38
Metadata Status	39
Decoder (RB-VHDDD8)	40
Control	40
PCM Metadata	41
Metadata Status	42
External Audio I/O (RB-VHEDD8)	43
External Audio Outputs (RB-VHDDD8)	44
Level Control	45
Remotes	47

Technical Specification 49

Appendix 52



CONTENTS

FIGURES



FIGURES

Figures	
Fig A: Packing List	iii
Fig B: Power Connections	iv
Fig C: Mains Lead Table	v
Fig D: RB-RK3 Large Redbox Rear Rack-mount Kit.	v
Fig 1-1: RB-VHEDD8 Front Panel.	1
Fig 1-2: RB-VHDDD8 Front Panel.	2
Fig 1-3: RB-VHDDD8 System Block Diagram.	3
Fig 1-4: RB-VHEDD8 System Block Diagram.	3
Fig 1-5: RB-VHDDD8 Front Panel Indicators & Controls.	4
Fig 1-6: RB-VHEDD8 Front Panel Indicators & Controls.	4
Fig 1-7: RB-VHEDD8 video input status screen.	9
Fig 1-8: RB-VHEDD8 Dolby E Encoder Status Screen.	10
Fig 1-9: RB-VHEDD8 Metadata Status Screen showing the Dialogue Normalization parameter.	10
Fig 1-10: RB-VHDDD8 video input status screen.	12
Fig 1-11: RB-VHDDD8 Dolby Decoder Status Screen when decoding Dolby Digital.	13
Fig 1-12: RB-VHDDD8 Dolby E Decoder Status Screen when decoding Dolby Digital.	13
Fig 1-13: RB-VHDDD8 Metadata Status Screen showing the Dialogue Normalization parameter.	13
Fig 1-14 RB-VHDDD8 Main Menu Screen.	15
Fig 2-1: SCI Login Screen.	31
Fig 2-2: RB-VHEDD8 System Screen.	32
Fig 2-3: RB-VHDDD8 System Screen.	34
Fig 2-4: RB-VHDDD8 Embed Screen.	36
Fig 2-5: RB-VHEDD8 Encoder Control Screen.	37
Fig 2-6: RB-VHEDD8 Encoder Meta Control Screen.	38
Fig 2-7: RB-VHEDD8 Encoder Meta Status Screen.	39
Fig 2-8: RB-VHDDD8 Decoder Control Screen.	40



Warranty

Warranty and Liability

Important: the purchaser is advised to read this clause

- (a) The Company agrees to repair or (at its discretion) replace Goods which are found to be defective (fair wear and tear excepted) and which are returned to the Company within 12 months of the date of despatch provided that each of the following are satisfied:
- (i) notification of any defect is given to the Company immediately upon its becoming apparent to the Purchaser;
 - (ii) the Goods have only been operated under normal operating conditions and have only been subject to normal use (and in particular the Goods must have been correctly connected and must not have been subject to high voltage or to ionising radiation and must not have been used contrary to the Company's technical recommendations);
 - (iii) the Goods are returned to the Company's premises at the Purchaser's expense;
 - (iv) any Goods or parts of Goods replaced shall become the property of the Company;
 - (v) no work whatsoever (other than normal and proper maintenance) has been carried out to the Goods or any part of the Goods without the Company's prior written consent;
 - (vi) the defect has not arisen from a design made, furnished or specified by the Purchaser;
 - (vii) the Goods have been assembled or incorporated into other goods only in accordance with any instructions issued by the Company;
 - (viii) the defect has not arisen from a design modified by the Purchaser;
 - (ix) the defect has not arisen from an item manufactured by a person other than the Company.

In respect of any item manufactured by a person other than the Company, the Purchaser shall only be entitled to the benefit of any warranty or guarantee provided by such manufacturer to the Company.

- (b) In respect of computer software supplied by the Company the Company does not warrant that the use of the software will be uninterrupted or error free.



WARRANTY

WARRANTY



WARRANTY

- (c) The Company accepts liability:
 - (i) for death or personal injury to the extent that it results from the negligence of the Company, its employees (whilst in the course of their employment) or its agents (in the course of the agency);
 - (ii) for any breach by the Company of any statutory undertaking as to title, quiet possession and freedom from encumbrance.
- (d) Subject to conditions (a) and (c) from the time of despatch of the Goods from the Company's premises the Purchaser shall be responsible for any defect in the Goods or loss, damage, nuisance or interference whatsoever consequential economic or otherwise or wastage of material resulting from or caused by or to the Goods. In particular the Company shall not be liable for any loss of profits or other economic losses. The Company accordingly excludes all liability for the same.
- (e) At the request and expense of the Purchaser the Company will test the Goods to ascertain performance levels and provide a report of the results of that test. The report will be accurate at the time of the test, to the best of the belief and knowledge of the Company, and the Company accepts no liability in respect of its accuracy beyond that set out in Condition (a).
- (f) Subject to Condition (e) no representation, condition, warranty or other term, express or implied (by statute or otherwise) is given by the Company that the Goods are of any particular quality or standard or will enable the Purchaser to attain any particular performance or result, or will be suitable for any particular purpose or use under specific conditions or will provide any particular capacity, notwithstanding that the requirement for such performance, result or capacity or that such particular purpose or conditions may have been known (or ought to have been known) to the Company, its employees or agents.
- (g)
 - (i) To the extent that the Company is held legally liable to the Purchaser for any single breach of contract, tort, representation or other act or default, the Company's liability for the same shall not exceed the Price of the Goods.
 - (ii) The restriction of liability in Condition (g)(i) shall not apply to any liability accepted by the Seller in Condition (c).
- (h) Where the Goods are sold under a consumer transaction (as defined by the Consumer Transactions (Restrictions on Statements) Order 1976) the statutory rights of the Purchaser are not affected by these Conditions of Sale.



Unpacking the RB-VHEDD8/RB-VHDDD8

The RB-VHEDD8/RB-VHDDD8 is shipped with the following equipment. Please check your packaging to ensure that you have all of the items below. If anything is missing, please contact the supplier of your equipment immediately.

Item	Quantity RB-VHEDD8/RB-VHDDD8
RB-VHEDD8/RB-VHDDD8	1
IEC Mains lead fitted with moulded mains plug	1
Handbook and warranty card	1

Fig A: Packing List

Each RB-VHEDD8/RB-VHDDD8 is shipped in protective packaging and should be inspected for damage before use. Where an item is found to have transit damage, notify the carrier immediately with all the relevant details of the shipment. Packing materials should be kept for inspection and also for if the product needs to be returned.

Returning the Warranty Card

In order to register the date of purchase so that we can keep you informed of any design improvements or modifications, it is important to complete the warranty registration document that is enclosed and return it to Sonifex Ltd in the UK.

For your own records you should write down the serial number (which can be found on the rear of the RB-VHEDD8/RB-VHDDD8).

Serial Number
---------------	-------



WARRANTY

SAFETY INFORMATION



SAFETY INFORMATION

Safety Information

Safety of Mains Operated Equipment



This equipment has been designed to meet the safety regulations currently advised in the country of purchase and it conforms to the safety regulations specified by use of the CE Mark.

Warning : There are no user serviceable parts inside the equipment. If you should ever need to look inside the unit, always disconnect the mains supply before removing the equipment covers.

Voltage Setting Checks

Ensure that the machine operating voltage is correct for your mains power supply by checking the box in which your Redbox was supplied. The voltage is shown on the box label. This product is continuously rated 85 - 264 VAC, 47 - 63Hz. Please note that all Redboxes are either switchable between 115V and 230V, or have a universal power supply.

Fuse Rating

The RB-VHEDD8/RB-VHDDD8 is supplied with a single fuse in the live conducting path of the mains power input. For reasons of safety it is important that the correct rating and type of fuse is used. Incorrectly rated fuses could present a possible fire hazard, under equipment fault conditions. The fuse rating for the RB-VHEDD8/RB-VHDDD8 is:

Continuously rated 85 - 264 VAC, 47 - 63Hz - 2A, 5 x 20mm B8

The active fuse is fitted on the outside rear panel of the unit.

Power Cable and Connection

An IEC power connector is supplied with the RB-VHEDD8/RB-VHDDD8 which has a moulded plug attached – this is a legal requirement. If no moulded plug has been supplied with your RB-VHEDD8/RB-VHDDD8, please contact your supplier, because an IEC connector is always supplied from the Sonifex factory.

If for any reason, you need to use the RB-VHEDD8/RB-VHDDD8 with a different power cable, you should use the following wiring guidelines.

Wire Colour	Connection
Green, or green and yellow	Earth (E)
Blue, or Black	Neutral (N)
Brown, or Red	Live (L)

Fig B: Power Connections

Connect the equipment in accordance with the connection details and before applying power to the unit, check that the machine has the correct operating voltage for your mains power supply.

Important Note : The terminal marked on the rear panel must be earthed.



Ordering the Correct Mains Lead

When ordering a Redbox from Sonifex, it is helpful if you can specify your required operating voltage and mains lead. After the product code add:





UK, for 230V, UK 3 pin to IEC lead	
EC, for 230V, European Schuko 2 pin to IEC lead	
US, for 115V, 3 pin to IEC lead	
AU for 230V, Australasian 3 pin to IEC lead	

Fig C: Mains Lead Table

E.g. order RB-VHEDD8/RB-VHDDD8 UK for a UK IEC lead to be supplied.

Installation Information

Atmosphere

The units should be installed in an area that is not subject to excessive temperature variation (<0°C, >50°C), moisture, dust or vibration.

Electromagnetic Radiation

The cover is connected to earth by means of the fixing screws. It is essential to maintain this earth ground connection to ensure a safe operating environment and provide electromagnetic shielding.

Fitting Redboxes

Redboxes can be fixed to the underside of a mixing desk, or other surfaces using 4.2mm holes in the sides and fixed with 2 x M4 screws or 2 x No. 6 countersink wood screws.

They can also be rack-mounted, with either the front, or rear of the Redbox positioned at the front of the rack:

Rear Mounting The RB-VHEDD8/RB-VHDDD8: The **RB-RK3** 1U rear panel rack kit can be used for large Redboxes such as the RB-VHEDD8 & RB-VHDDD8.



Fig D: RB-RK3 Large Redbox Rear Rack-mount Kit.

Note: When fitting the rear-mounting rack-kits, a notch has been left on the inside of the right-hand rack-piece for the mains cable to pass through. Make sure that the mains cable has been put through the notch before attaching the right hand rack-piece.



SAFETY INFORMATION

SAFETY & INSTALLATION INFORMATION



WEEE & RoHS Directives - Sonifex Statement



The Waste Electrical and Electronic Equipment (WEEE) Directive was agreed on 13 February 2003, along with the related Directive 2002/95/EC on Restrictions of the use of certain Hazardous Substances in electrical and electronic equipment (RoHS).

The **Waste Electrical and Electronic Equipment Directive (WEEE)** aims to minimise the impacts of electrical and electronic equipment on the environment during their life times and when they become waste. It applies to a huge spectrum of products. It encourages and sets criteria for the collection, treatment, recycling and recovery of waste electrical and electronic equipment. All products manufactured by Sonifex Ltd have the WEEE directive label placed on the case. It gives a contact for individuals who are unsure about the correct procedure when the product has reached its “end of use”.

Sonifex Ltd will be happy to give you information about local organisations that can reprocess the products, or alternatively all products that have reached “end of use” can be returned to Sonifex and will be reprocessed correctly free of charge.

Sonifex Ltd has phased out the use of certain hazardous substances identified in the European Union’s **Restriction of Hazardous Substances (RoHS)** directive. The RoHS directive limits the use of certain hazardous substances currently used in EEE manufacture, including lead, mercury, cadmium, hexavalent chromium, and halide-containing compounds PBB (polybrominated biphenyl) and PBDE (polybrominated diphenyl ether). Elimination of these substances will result in more environmentally friendly recycling of electronic equipment. For the products which Sonifex manufacture, the main area where products were affected was in the use of lead for manufacturing and assembling electronics circuit boards.

Sonifex Ltd practices lead-free (LF) manufacturing processes. LF solder is used on the surface-mount PCB manufacturing processes and for hand soldering. The printed circuit boards (PCBs) used are either gold plated, or immersion tin plated, both of which use no lead. Historically the PCBs were hot air solder levelled (HASL) PCBs which used tin/lead based solder.

The manufacturing processes include the assembly of purchased components from various sources. Product is offered as RoHS compliant, or LF, only after sufficient evidence is received from the component manufacturers that their components are RoHS compliant. Sonifex Ltd relies solely on the distributor, or manufacturer, of the components for identification of RoHS compliance. Thus whilst every effort is made to ensure compliance, Sonifex Ltd makes no warranty, or certification, or declaration of compliance concerning said components.

Sonifex Ltd defines “Lead Free” as pertaining to any product, which has been manufactured by Sonifex Ltd using components which have been declared by the manufacturers as “Lead Free”. All statements by Sonifex Ltd of RoHS compliance are based on component manufacturer documentation.

RB-VHEDD8 – 3G/HD/SD-SDI Dolby E Encoder



Fig 1-1: RB-VHEDD8 Front Panel.

The RB-VHEDD8 is an SDI audio de-embedder and re-embedder with Dolby E Encoding capabilities. Dolby E encodes up to 8 channels of audio into two channels of an AES digital audio stream which is then embedded onto any of the available groups within each of the two video output paths. The encoded Dolby E bitstream is also available via a dedicated output on the rear panel.

The audio inputs to the Encoder can be selected to come from the external digital audio inputs via the BNC or D-type connections on the rear panel or from embedded audio contained in the incoming SDI input. The outputs from the de-embedder can also be re-embedded into the video outputs, along with the encoder inputs.

The digital audio I/O connections are transformer-coupled balanced line interfaces and can be configured to be either 75ohm (AES 3ID) or 110ohm (AES 3) impedance through either a BNC or via the D-type connector. These connections are paralleled, allowing one type to be used per input or output.

It has a triple rate SDI receiver with automatic input rate detection and equalisation along with two re-clocked and individually buffered SDI outputs. It supports the full range of 3G, HD and SD standards from NTSC and PAL up to 1080p 60Hz.

The metadata used for the encoding process can be selected to come from either the external 9-pin D-type on the rear panel, from metadata embedded into the vertical blanking area of the video input (SMPTE 2020), or by settings stored internally.

There is also remote I/O available from the rear panel through a 25 way D-type connector. These are fully configurable.

The unit is controlled locally through the front panel display but can be remote controlled via an Ethernet connection using the Sonifex SCi software.

There is independent level control for every channel, which can be adjusted from -24dB through to +24dB in 0.5dB steps.

Dolby and the double-D symbol are registered trademarks of Dolby Laboratories





RB-VHDD8 – 3G/HD/SD-SDI Dolby E/Dolby Digital Decoder



Fig 1-2: RB-VHDD8 Front Panel.

The RB-VHDD8 is an SDI audio de-embedder and re-embedder with Dolby E & Dolby Digital Decoding capabilities. It de-embeds and decodes a selected Dolby E or Dolby Digital bitstream embedded in the video input. The outputs from the decoder and the de-embedder can then be re-embedded onto either of the two SDI outputs and also transmitted on a BNC or D-type situated on the rear panel. The encoded Dolby bitstream is also available via a dedicated output on the rear panel.

It has a triple rate SDI receiver with automatic input rate detection and equalisation along with two re-clocked and individually buffered SDI outputs. It supports the full range of 3G, HD and SD standards from NTSC and PAL up to 1080p 60Hz.

The digital audio output connections are transformer-coupled balanced line interfaces and can be configured to be either 75ohm (AES 3ID) or 110ohm (AES 3) output impedance through either a BNC or via the D-type connector. These output connections are paralleled, allowing one type to be used per output.

The metadata output from the decoder is transmitted using RS-485 via the external 9-pin D-type on the rear panel and can also be embedded into the vertical blanking space (SMPTE-2020) of the two SDI outputs.

There is also remote I/O available from the rear panel through a 25 way female D-type connector. These are fully configurable.

The unit is controlled locally through the front panel display but can also be remote controlled via an Ethernet connection using the Sonifex SCi software.

There is independent level control for every channel, which can be adjusted from -24dB through to +24dB in 0.5dB steps.

Embedding and De-Embedding Overview

Audio embedding is the process of taking one or more audio signals, formatting them into packets and then placing them into the ancillary or blanking space of a video signal. Audio de-embedding is the process of retrieving this audio data from the video signal but not necessarily removing it. These two processes are standardised by two SMPTE documents, SMPTE-272M for SD-SDI and SMPTE-299M for HD-SDI and 3G-SDI.

Both of these standards allow for the embedding of 16 channels of 24-bit, 48kHz audio. Which are divided down into 4 groups of 4 channels.

Each standard consists of a control packet and an audio data packet. The control packets hold certain control information about the audio to aid in the de-embedding process or any other receiving equipment. There is one control packet per group, these packets are optional for SD. The control packet is normally placed in the horizontal blanking period once per field or frame. The audio data packets contain the actual audio sample data. There are considerable differences between SD and HD, the main ones being that SD data packets contain only 20-bit data and are of variable length while the HD data packets contain 24-bit data and are of fixed length. The HD packets also provide an error correction and detection method. The SD standard consists of a further packet, the extended data packet. These packets contain the 4 least significant bits of the audio samples to provide full 24-bit audio.



System Block Diagram (RB-VHDDD8)

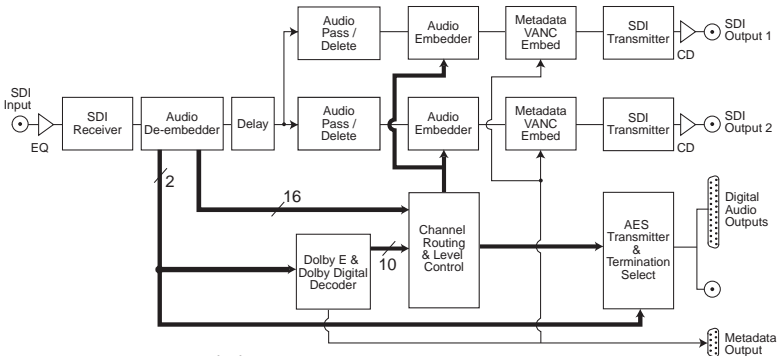

Fig 1-3: RB-VHDDD8 System Block Diagram.

System Block Diagram (RB-VHEDD8)

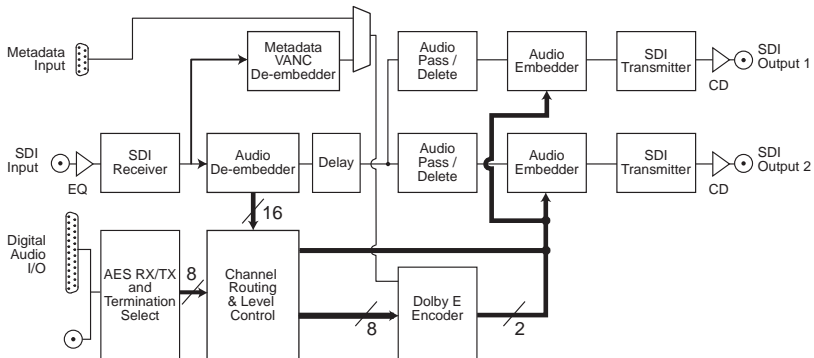

Fig 1-4: RB-VHEDD8 System Block Diagram.



Front Panel Indicators & Controls



Fig 1-5: RB-VHDDD8 Front Panel Indicators & Controls.



Fig 1-6: RB-VHEDD8 Front Panel Indicators & Controls.

Power Led

The POWER LED illuminates whilst internal power is present within the unit. If this indicator is not on, the most likely reason is simply the absence of mains power, but under fault conditions it may also indicate a ruptured mains fuse or a problem with the internal power supply module.

Reset Button

In the unlikely event that the unit fails to respond, press the reset button to reboot the unit.

Selecting The Main Menu

The units configuration options are accessed from the main system menu. To access the main system menu, press and hold the rotary CONTROL for at least 1.5 seconds. The menu structure is arranged in a multi-tiered format with several menu items providing access to sub-menus. To select a menu item, turn the rotary control until the required item is highlighted, then press the rotary control to select the item. Each configuration is shown as a list of available options. The currently selected option will be shown with a tick along side it. The last item shown in each menu is CLOSE. Selecting close exits the system menu and returns to the main display. In each sub-menu, the penultimate item shown is BACK. Selecting back displays the previous menu.

Rear Panel Connections

Mains Power

Power is applied via a standard three-pin IEC male socket. Mains voltages between 85V and 264V AC and frequencies between 47 and 63Hz are accepted without adjustment. A 2A, 5 x 20mm SB fuse is used. The Earth pin MUST be connected to ensure safety.

Remote Control

The unit can be controlled remotely via Ethernet using the Sonifex SCi software. Using remote control allows the user to monitor the status of the unit and also set various options and settings.



The Ethernet port is connected using a standard RJ-45 connector on the rear of the panel. It is a 10/100Mbps link. The unit is shipped with DHCP enabled to allow the unit to be plug and play if the users local area network has a DHCP server. If one is not available on the network the unit can be set to use a static address set through via the front panel. This static address is set to 192.168.0.100. If DHCP is not required then this can be disabled.

The Network connectors pin assignments are as follows:

Network Connector (RJ-45)	
Pin No.	Function
1	Transmit Data (Positive)
2	Transmit Data (Negative)
3	Receive Data (Positive)
4	No connection
5	No connection
6	Receive Data (Negative)
7	No connection
8	No connection

Metadata

Metadata is used by Dolby E and Dolby Digital encoders and decoders to configure and control the encode and decode process. Encoders may require that this metadata information come from an external source, while the decoders output this information. Metadata is normally transmitted as a serial RS-485 link, but can also be embedded within the vertical ancillary space of a video stream (SMPTE 2020). The RB-VHEDD8 and RB-VHDDD8 units makes use of both these methods of metadata transport.

For the RB-VHEDD8, Dolby E metadata is presented to the unit via a 9 way female D-type connection on the rear panel. Metadata can also be selected to be de-embedded from the video input.

For the RB-VHDDD8, Dolby E metadata is output from the unit via a 9 way female D-type connection on the rear panel. Metadata is only available when the unit is decoding a valid Dolby E bitstream or when PCM metadata is enabled and the decoder is receiving a PCM bitstream. Metadata can also be selected to be embedded into the video.

The metadata connectors pin assignments are as follows:

Metadata Connector (9-pin female D-type)	
Pin No.	Function
1	Shield
2	Transmit Data (Negative)
3	Receive Data (Positive)
4	Ground
5	No connection
6	Ground
7	Transmit Data (Positive)
8	Receive Data (Negative)
9	Shield



Serial Video I/O

SDI Input

The SDI input is connected using a single female BNC and has a 75 ohm input impedance. It is a triple rate SDI receiver with automatic input rate detection and equalisation. It supports the full range of 3G, SD and HD standards from NTSC and PAL up to 1080p 60Hz. The status of the input is available on the video status screen on the front panel display..

SDI Outputs

The two SDI outputs are connected using the two female BNC connectors on the rear panel. They have a 75 ohm output impedance in accordance with the SMPTE standard and are both re-clocked and independently buffered. Each output can be configured separately for embedding and group deletion settings.

Ref Loop and Ref In

These connections are not currently used and should be left unconnected. These may be defined for use in later versions of firmware.

RB-VHEDD8 Audio Connections

The RB-VHEDD8 has 4 digital audio input connections and a dedicated Dolby E encoded digital output connection available on the rear panel. The digital audio connections are transformer-coupled balanced line interfaces and can be configured to be either 75ohm (AES 3ID) or 110ohm (AES 3) input or output impedance through either a BNC or via the D-type connector. These connections are paralleled, allowing one type to be used per connection.

Digital Audio Inputs

The digital audio inputs **CH12**, **CH34**, **CH56** and **CH78** can be used as inputs to the encoder and also embedded directly into the video, as long as the inputs are synchronous to the video clock. The first two inputs are sample rate converted so that they are synchronous with the video, although this process can be disabled if necessary.

Dolby E Output

The output labeled as **DO** is a dedicated Dolby E output. This is the output from the encoder and replicates the Dolby E bitstream that is embedded into the video outputs. This provides an output that can be connected to other decoder or monitor equipment in the broadcast chain without the need of extra de-embedding equipment.

LTC Input

This input is not currently used. Do not connect anything to this input.

The digital audio D-type connectors pin assignments for RB-VHEDD8 are as follows:

Pin No.	Function	Pin No.	Function
1	Digital 1 In+	14	Digital 1 In-
2	Digital 1 In Ground	15	Digital 2 In+
3	Digital 2 In-	16	Digital 2 In Ground
4	Digital 3 In+	17	Digital 3 In-
5	Digital 3 In Ground	18	Digital 4 In+



6	Digital 4 In-	19	Digital 4 In Ground
7	Dolby Output 1+	20	Dolby Output 1-
8	Dolby Output 1 Ground	21	Do not connect
9	Do not connect	22	Do not connect
10	Do not connect	23	Do not connect
11	Do not connect	24	Do not connect
12	Do not connect	24	Do not connect
13	No Connection		

Dolby Embedder, Unbalanced Input Grounding

The Redbox Dolby® Encoder products use differential inputs that can be terminated with either 75Ω or 110Ω for unbalanced or balanced inputs, respectively.

For unbalanced inputs, all that should be required is to set the inputs to 75Ω. However it has been found in rare circumstances that in this case there are issues with grounding when the input is connected from other manufacturers' products.

Should problems of this nature occur, internal ground link jumpers have been provided on the RB-AIM-DE sub-board PCB to correct the problem. These short to ground one of the differential inputs, effectively providing a 'true' unbalanced connection.

It's also possible to do the same for the digital output using link J6.

The jumpers are labelled as follows:

I/O Type	Ground Link Reference
Inputs 1 and 2	J2
Inputs 3 and 4	J3
Inputs 5 and 6	J4
Inputs 7 and 8	J5
Digital Output	J6

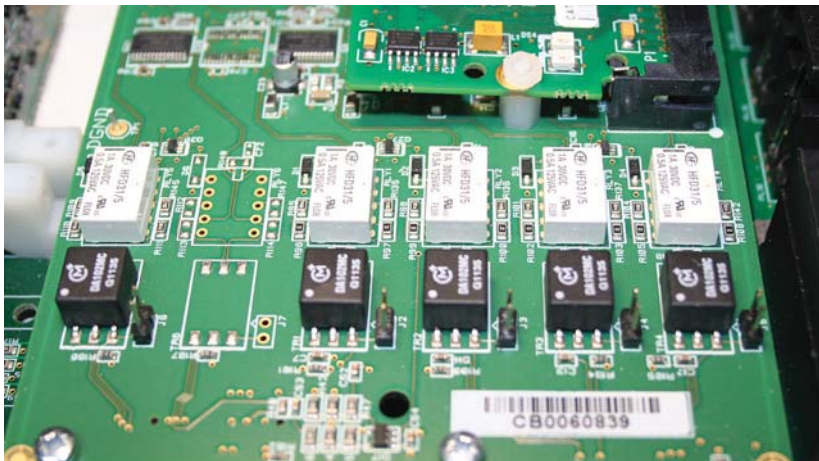

INTRODUCTION



RB-VHDDD8 Audio Connections

The RB-VHDDD8 has 6 digital audio output connections available on the rear panel. The digital audio output connections are transformer-coupled balanced line interfaces and can be configured to be either 75ohm (AES 3ID) or 110ohm (AES 3) output impedance through either a BNC or via the D-type connector. These output connections are paralleled, allowing one type to be used per output.

The digital outputs are always output at 48kHz and will be synchronous to the video signal. No sample rate conversion is applied to the digital outputs.

Dolby Output

The output labeled as **DO** is a dedicated Dolby output. This output is an exact copy of the data that is selected to be sent to the Decoder. This provides an output that can be connected to other decoder or monitor equipment in the broadcast chain without the need of extra de-embedding equipment.

Digital Audio Outputs

The outputs labeled as **CH1/2**, **CH3/4**, **CH5/6**, **CH7/8** and **AUX** are configurable digital audio outputs that can be sourced from either the decoder outputs or the de-embedder outputs on a per channel basis. By default they are sourced from the Dolby Decoder outputs, and the labels relate to this. The **AUX** channels are the down-mix output from the Decoder.

The digital audio D-type connectors pin assignments for RB-VHDDD8 are as follows:

Pin No.	Function	Pin No.	Function
1	Digital 1 Out+	14	Digital 1 Out-
2	Digital 1 Out Ground	15	Digital 2 Out+
3	Digital 2 Out-	16	Digital 2 Out Ground
4	Digital 3 Out+	17	Digital 3 Out-
5	Digital 3 Out Ground	18	Digital 4 Out+
6	Digital 4 Out-	19	Digital 4 Out Ground
7	Dolby Output 1+	20	Dolby Output 1-
8	Dolby Output 1 Ground	21	Digital Aux Out +
9	Digital Aux Out -	22	Digital Aux Out Ground
10	Do not connect	23	Do not connect
11	Do not connect	24	Do not connect
12	Do not connect	24	Do not connect
13	No Connection		

Remote I/O

There are 8 remote inputs and outputs available on the unit, through a 25 way D-type female connection on the rear panel. The remote outputs are provided as open collector outputs.

The outputs are fully configurable through the front panel menu control or from the remote control software. They can be set to active high/low, latched/momentary and to a number of triggering events. See the REMOTE OUTPUTS menu selection for more information.



the REMOTE OUTPUTS menu selection for more information. The remote inputs are currently not used.

The remote I/O connectors pin assignments are as follows:

Pin No.	Function	Pin No.	Function
1	Remote Output 0	14	Remote Output 1
2	Ground	15	Remote Output 2
3	Remote Output 3	16	Ground
4	Remote Output 4	17	Remote Output 5
5	Ground	18	Remote Output 6
6	Remote Output 7	19	Ground
7	Remote Input 0	20	Remote Input 1
8	Ground	21	Remote Input 2
9	Remote Input 3	22	Ground
10	Remote Input 4	23	Remote Input 5
11	Ground	24	Remote Input 6
12	Remote Input 7	25	Ground
13	No connection		



INTRODUCTION

RB-VHEDD8 Status Screens

There are three separate status screens available to switch between to display various status information about the unit and its operation. The first status screen displays information about the video input. The second screen shows the status of the Dolby E encoder and the third displays the OUTPUT metadata information from the encoder on a parameter by parameter basis. To switch between the different screens press the rotary CONTROL knob. Each status screen is described in more detail below.

Video Input Status Screen

This status screen displays information about the SDI input. The SDI input rate and format, along with audio group detection and the program configuration currently being used by the encoder. If an audio group is detected the the relevant block number will be highlighted, if that group is not present then the box will be clear.

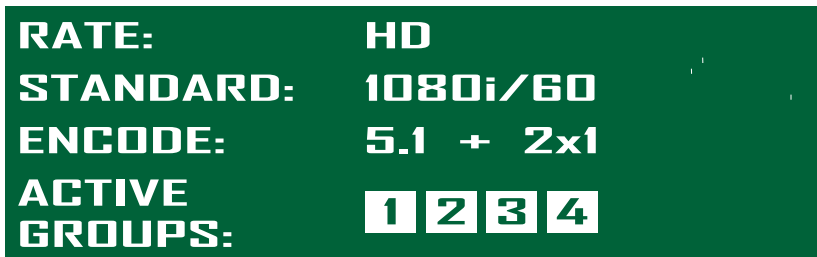

Fig 1-7: RB-VHEDD8 video input status screen.



Dolby E Encoder Status Screen

This status screen provides information about the encoder and encoding process. This information includes the encoding status; ACTIVE, STOPPED, or PASS. The program configuration, selected encoding bit-depth, frame rate and the metadata source.

It will also display an ERROR symbol whenever the encoding process reports an error.

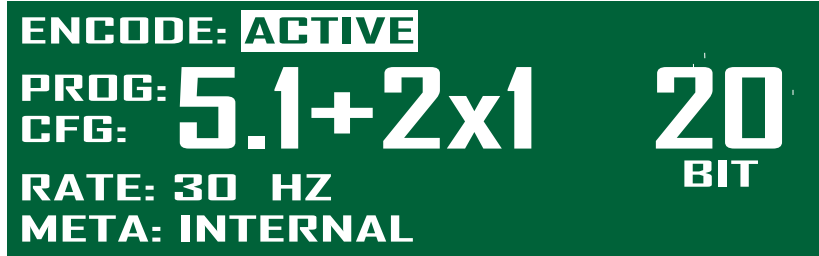

Fig 1-8: RB-VHEDD8 Dolby E Encoder Status Screen.

Metadata Status Screen

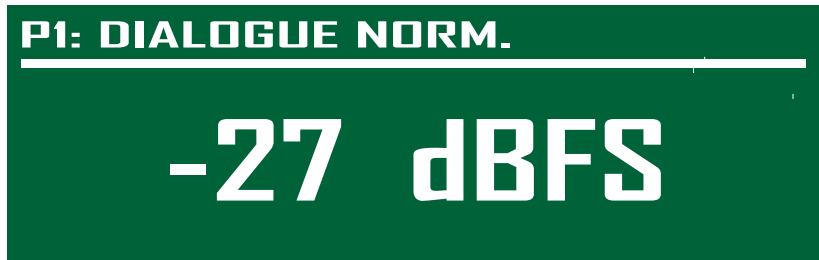

Fig 1-9: RB-VHEDD8 Metadata Status Screen showing the Dialogue Normalization parameter.



This status screen displays all of the available metadata information on a parameter by parameter basis. To go to the next parameter turn the rotary CONTROL knob clockwise. To go to the previous parameter turn the rotary CONTROL knob counter-clockwise. When encoding a Dolby E bitstream with more than one program, pressing the rotary CONTROL knob will skip to the next program. The list of parameters available are shown in the table below.



INTRODUCTION

Dolby E
Program Text
Dialogue Normalization
Channel Mode
LFE Channel
Bitstream Mode
Line Mode Profile
RF Mode Profile
Center Downmix Level
Surround Downmix Level
Dolby Surround Mode
Mixing Level
Room Type
Preferred Downmix
Lt/Rt Center Downmix Level
Lt/Rt Surround Downmix Level
Lo/Ro Center Downmix Level
Lo/Ro Surround Downmix Level
Dolby Surround EX Mode
DC Filter
Lowpass Filter
LFE Filter
Surround Phase Shift
Surround 3 dB Attenuator



RB-VHDDD8 Status Screens

There are three separate status screens available to switch between to display various status information about the unit and its operation. The first status screen displays information about the video input. The second screen shows the status of the Dolby decoder and the third displays the decoder metadata information on a parameter by parameter basis. To switch between the different screens press the rotary CONTROL knob. Each status screen is described in more detail below.

Video Input Status Screen

This status screen displays information about the SDI input. The SDI input rate and format, along with audio group detection and the bit-stream type being sent to the decoder. If an audio group is detected the relevant block number will be highlighted, if that group is not present then the box will be clear.

RATE:	HD
STANDARD:	1080i/50
DECODE:	DOLBY E
ACTIVE GROUPS:	1 2 3 4

Fig 1-10: RB-VHDDD8 video input status screen.

Dolby Decoder Status Screen

This status screen provides information about the decoder and decoding process. The type of information being displayed will differ depending on whether a Dolby Digital, Dolby E or PCM bitstream is being decoded.

When a Dolby E bitstream is being decoded, this screen will display the professional metadata information including Program Configuration, Frame Rate and Bit-Depth. It will also display an ERROR symbol whenever an error is detected in the decode process.

When a Dolby Digital bitstream is being decoded the screen will display the Channel Mode and Data Rate. It will also display an ERROR symbol whenever an error is detected in the decode process.

When a PCM bitstream is presented to the decoder this screen will display the latency through the decoder and also if metadata output is enabled.

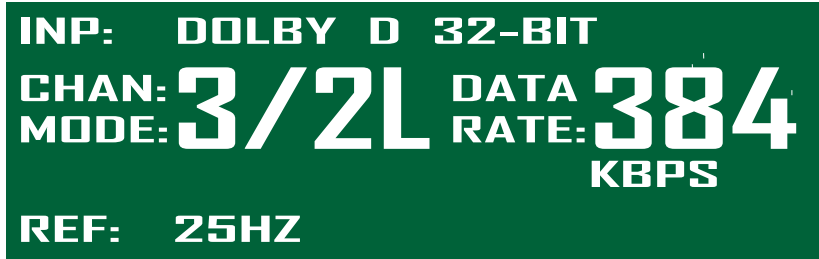

Fig 1-11: RB-VHDD8 Dolby Decoder Status Screen when decoding Dolby Digital.

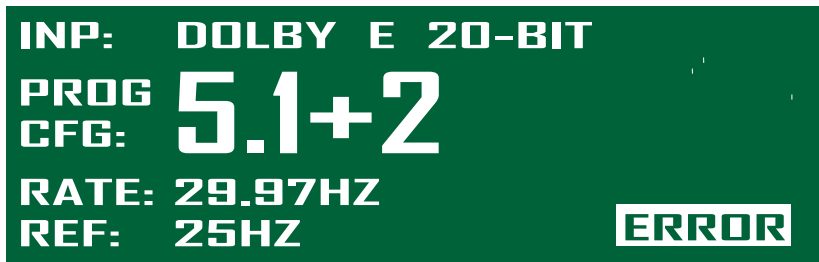

Fig 1-12: RB-VHDD8 Dolby E Decoder Status Screen when decoding Dolby Digital.

Metadata Status Screen

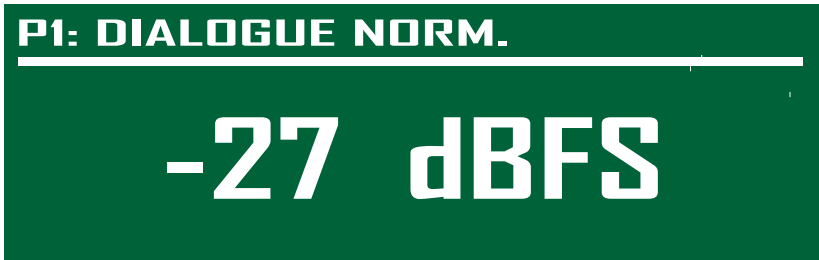

Fig 1-13: RB-VHDD8 Metadata Status Screen showing the Dialogue Normalization parameter.

This status screen displays all of the available metadata information on a parameter by parameter basis. These values shown will depend on the bit-stream type. To go to the next parameter turn the rotary CONTROL knob clockwise. To go to the previous parameter turn the rotary CONTROL knob counter-clockwise. When decoding a Dolby E bitstream with more than one program, pressing the rotary CONTROL knob will skip to the next program. The list of parameters available are shown in the table below.



1

INTRODUCTION



INTRODUCTION

Dolby E	Dolby Digital
Program Text	Data-rate
Dialogue Normalization	Dialogue Normalization
Channel Mode	Channel Mode
LFE Channel	LFE Channel
Bitstream Mode	Bitstream Mode
Line Mode Profile	Line Mode Profile
RF Mode Profile	RF Mode Profile
Center Downmix Level	Center Downmix Level
Surround Downmix Level	Surround Downmix Level
Dolby Surround Mode	Dolby Surround Mode
Mixing Level	Mixing Level
Room Type	Room Type
Preferred Downmix	Preferred Downmix
Lt/Rt Center Downmix Level	Lt/Rt Center Downmix Level
Lt/Rt Surround Downmix Level	Lt/Rt Surround Downmix Level
Lo/Ro Center Downmix Level	Lo/Ro Center Downmix Level
Lo/Ro Surround Downmix Level	Lo/Ro Surround Downmix Level
Dolby Surround EX Mode	Dolby Surround EX Mode
DC Filter	
Lowpass Filter	
LFE Filter	
Surround Phase Shift	
Surround 3 dB Attenuator	

The Main Menu

To access the main menu, press and hold the rotary CONTROL knob and follow the instructions on page 4.

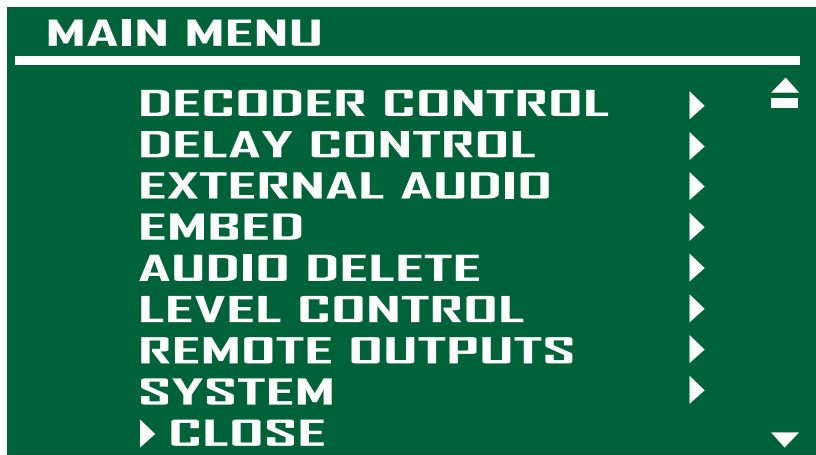

Fig 1-14 RB-VHDDD8 Main Menu Screen.

Decoder Control (RB-VHDDD8)

This selection shows the Decoder Control sub-menu. It provides access to all options that control the decoding process. The sub-menu items are SOURCE, DOLBY DIGITAL, DOLBY E, PCM, PCM METADATA and AUX. OUTPUT.

Source

This option selects the audio channel pair from the de-embedder to send to the decoder. The selected channel pair must be a valid Dolby E or Dolby Digital bit-stream or the decoder will treat it as linear PCM and pass the audio through the decoding block. The available options are **GROUP 1 – CH1\2, GROUP 1 – CH3\4, GROUP 2 – CH1\2, GROUP 2 – CH3\4, GROUP 3 – CH1\2, GROUP 3 – CH3\4, GROUP 4 – CH1\2 and GROUP 4 – CH3\4**. The default selection is **GROUP 1 – CH1\2**.





Dolby Digital

This selection shows the Dolby Digital sub-menu. The sub-menu items are **AES CHANNEL SELECT**, **STREAM SELECT**, **LISTENING MODE**, **DYNAMIC RANGE CONTROL** and **PRO LOGIC DECODE**.

AES Channel Select

This option selects which AES channel within the selected channel pair to use as the source for the Decoder when the incoming data is configured in professional 16-bit format. Available options are CHANNEL 1 and CHANNEL 2. The default selection is CHANNEL 1.

Stream Select

This option selects the stream number to be decoded when multiple Dolby Digital bitstreams are embedded within the selected channel pair sent to the decoder. When AUTO is selected, the lowest stream number detected will be decoded. The available options are AUTO, STREAM 1, STREAM 2, STREAM 3, STREAM 4, STREAM 5, STREAM 6 and STREAM 7. The default selection is AUTO.

Listening Mode

This option selects the main channel output listening mode for Dolby Digital bitstreams. See Appendix for the definition of each selection. The available options are FULL, EX, 3 STEREO, PHANTOM, STEREO and MONO. The default selection is FULL.

Dynamic Range Control

This option selects the main output Dynamic Range Control mode. The available options are LINE MODE, RF MODE, CUSTOM MODE and BYPASS MODE. The default selection is LINE MODE.

Pro-Logic Decode

This option controls the Dolby Pro-Logic decode processing for Dolby Digital and PCM bitstreams. The available options are DISABLE and ENABLE. The default selection is DISABLE. This replicates the menu control from the PCM sub-menu.

Dolby E

This selection shows the Dolby E sub-menu. This contains the decoder controls when a Dolby E bit-stream is being decoded. The sub-menu item is **DIALOGUE NORMALIZATION**.

Dialogue Normalization

This option controls the application of the dialogue normalization value from the the metadata to the main outputs. The available options are DISABLE and ENABLE.

PCM

This selection shows the PCM sub-menu. This contains decoder controls when linear PCM is being sent to the decoder. The sub-menu items are **LATENCY**, **METADATA**, **PRO-LOGIC DECODE** and **PCM METADATA**.



Latency

This option specifies the amount of latency through the decoder when PCM bitstreams are being received. The available options are SINGLE FRAME and MINIMUM. The default selection is SINGLE FRAME.

Metadata

This option controls the metadata output when PCM bitstreams are being sent to the decoder. The metadata parameters are controlled from the PCM metadata menu selection in the Decoder Control sub-menu. The available options are DISABLE and ENABLE. The default selection is DISABLE.

Pro-Logic Decode

This option controls the Dolby Pro-Logic decode processing for Dolby Digital and PCM bitstreams. The available options are DISABLE and ENABLE. The default selection is DISABLE. This replicates the menu control from the Dolby Digital sub-menu.

PCM Metadata

This selection shows the PCM Metadata sub-menu. These are the Metadata parameter settings when PCM bitstreams are being sent to the decoder. For a full list of parameters see the Appendix.

Aux. Channel

This selection shows the Aux. Channel sub-menu. This contains the control parameters for the auxiliary (downmix) output of the Decoder. The sub-menu items are OUTPUT MODE, DRC MODE and Dolby E PROGRAM.

Output Mode

This option selects the downmix mode for the auxiliary output of the decoder. The available options are Lt/Rt, Lo/Ro, MONO and MUTE. The default selection is Lt/Rt.

DRC Mode

This option selects the DRC mode for the downmix output. The available options are LINE MODE and RF MODE. The default selection is LINE MODE.

Dolby E Program

This option selects the which Dolby E program downmix to output on the auxiliary output port. This is only valid when a Dolby E bitstream is being decoded. The available options are PROGRAM 1 to PROGRAM 8. The default selection is PROGRAM 1.



Encoder Control (RB-VHEDD8)

This selection shows the Encoder Control sub-menu. It provides access to all options that control the encoding process. The sub-menu items are **PROGRAM CONFIG**, **ENCODING MODE**, **FRAME RATE**, **BIT DEPTH**, **METADATA**, **REVERSION MODE**, **METADATA SOURCE** and **ENCODER INPUTS**.

Program Config

This option selects the Dolby E program configuration. Some of the selections are only available depending on the selected bit-depth of the encoding process. When it is set to 16-bit mode, only valid selections will be available. The available options are listed below along with an explanation of the configuration. The default selection is 5.1 + 2.

Dolby E Program Configurations	
5.1 + 2*	A 5.1 program (L,R,C,LFE,Ls,Rs) and a stereo program.
5.1 + 2 x 1*	A 5.1 program (L,R,C,LFE,Ls,Rs) and two mono programs.
4 + 4*	Two 4 channel programs, (L,R,C,S).
4 + 2 x 2*	A 4 channel program (L,R,C,S), and two stereo programs.
4 + 2 + 2 x 1*	A 4-channel program (L,R,C,S), a stereo program, and two mono programs.
4 + 4 x 1*	A 4-channel program (L,R,C,S) and four mono programs.
4 x 2*	Four stereo programs.
3 x 2 + 2 x 1*	Three stereo programs and two mono programs.
2 x 2 + 4 x 1*	Two stereo programs and four mono programs.
2 + 6 x 1*	A stereo program and six mono programs.
8 x 1*	Eight mono programs.
5.1	A 5.1 program (L,R,C,LFE,Ls,Rs).
4 + 2	A four channel program (L,R,C,S) and a stereo program.
4 + 2 x 1	A four channel program (L,R,C,S) and two mono programs.
3 x 2	Three stereo programs.
2 x 2 + 2 x 1	Two stereo programs and two mono programs.
2 + 4 x 1	A stereo program and four mono programs.
6 x 1	Six mono programs.
4	A four channel program (L,R,C,S).
2 + 2	Two stereo programs.
2 + 2 x 1	A stereo program and two mono programs.
4 x 1	Four mono programs.
7.1*	A 7.1 program (L,R,C,LFE,Ls,Rs,Bsl,Bsr)
7.1 Screen*	A 7.1 program (L,R,C,LFE,Ls,Rs,Le,Re)

* 20-bit Only.



Encoding Mode

This option selects the encoding mode. The available options are DOLBY E, PASSTHROUGH, DOLBY E -18dBFS, PASS -18dBFS, DOLBY E -20dBFS, PASS -20dBFS, DOLBY E SILENCE and PASS SILENCE.

- DOLBY E – Puts the unit into Dolby E encoding mode.
- PASSTHROUGH – The unit passes through the data/audio connected to the first two inputs on the encoder.
- DOLBY E -18dBFS – A Dolby E bitstream is generated containing a 1kHz tone at -18dBFS.
- PASS -18dBFS – A linear PCM bitstream is generated containing a 1kHz tone at -18dBFS.
- DOLBY E -20dBFS – A Dolby E bitstream is generated containing a 1kHz tone at -20dBFS.
- PASS -20dBFS – A linear PCM bitstream is generated containing a 1kHz tone at -20dBFS.
- DOLBY E SILENCE - A Dolby E bitstream is generated containing silence.
- PASS SILENCE – A linear PCM bitstream is generated containing silence.

Frame Rate

This option selects the encoding frame rate of the Dolby E bitstream. If the selected frame rate does not match the video input frame rate, the encoding process will stop. The available options are 23.98 FPS, 24 FPS, 25/50 FPS, 29.97/59.94 FPS and 30/60FPS.





Bit Depth

This option selects the bit-depth of the Dolby E encoded bit-stream. The encoder can be set to encode in 16 or 20-bit. When 16-bit is selected, only 6 channels can be encoded, restricting the program configuration selections. If a program configuration is selected with more than 6 channels, then 16-bit mode will not be available. The available options are 20-BIT and 16-BIT.

Metadata

This selection shows the Metadata sub-menu. It allows you to control the metadata parameters for all the available programs. These are the internal metadata values that are used when the external metadata inputs are not required or missing. The full list of settable parameters are listed below, but for more information on these please view the metadata guide available from the Dolby website.

Dolby E Metadata Parameters

Program Text
Dialogue Normalization
Channel Mode
LFE Channel
Bitstream Mode
Line Mode Profile
RF Mode Profile
Center Downmix Level
Surround Downmix Level
Dolby Surround Mode
Audio Production Information
Mixing Level
Room Type
Extended Bitstream Information
Preferred Downmix
Lt/Rt Center Downmix Level
Lt/Rt Surround Downmix Level
Lo/Ro Center Downmix Level
Lo/Ro Surround Downmix Level
Dolby Surround EX Mode
DC Filter
Lowpass Filter
LFE Filter
Surround Phase Shift
Surround 3 dB Attenuator



Reversion Mode

This option controls how the unit behaves when an external metadata source is selected and the signal is lost or removed. When INTERNAL metadata is selected as the source, this menu setting is ignored. The available options are LAST USED, INTERNAL and STOP ENCODING.

- LAST USED – Uses the last received external metadata values.
- INTERNAL – Uses the internal metadata settings.
- STOP ENCODING – The unit stops the encoding process.

Metadata Source

This option selects the source for the metadata parameters. The available options are EXTERNAL, INTERNAL and VANC.

- EXTERNAL – This selects the external RS-485 metadata input as the source for the metadata.
- INTERNAL – Selects the internal metadata settings.
- VANC – Selects metadata available in the vertical ancillary space of the video input.

Encoder Inputs

This selection shows the Encoder Inputs sub-menu. The sub-menu items are CHANNEL 1\2, CHANNEL 3\4, CHANNEL 5\6 and CHANNEL 7\8.

Channel 1\2, 3\4, 5\6, 7\8

These selections show the Channels sub-menu for the encoder inputs. The sub-menu items are USE EXTERNAL, CHANNEL 1 and CHANNEL 2.

Use External

This option sets the selected encoder input pair to use the dedicated external input connection. When this setting is disabled, the relevant encoder input pair uses the de-embedder channel selections. The available options are ENABLE and DISABLE.

Channel 1

This option selects the de-embedder source for channel 1 of the selected encoder input pair. This selection is only valid when the USE EXTERNAL menu option is set to DISABLE. The available options are the full list of de-embedder channels.

Channel 2

This option selects the de-embedder source for channel 2 of the selected encoder input pair. This selection is only valid when the USE EXTERNAL menu option is set to DISABLE. The available options are the full list of de-embedder channels.



Delay Control

This selection shows the Delay Control sub-menu and provides control over the video delay through the unit. The sub-menu items are MODE and ADJUST.

Mode

This selection shows the Mode sub-menu. The mode settings are AUTO and MINIMUM. The AUTO setting matches the video delay with audio encode/decode delay through the Dolby module. The MINIMUM setting provides minimum video delay through the unit, while still retaining the normal audio process delay through the Dolby module.

Adjust

This selection shows the Adjust sub-menu dialog box. This provides adjustment of the video delay through the unit when the delay is in AUTO mode. The adjustment range is from -10 ms to +10 ms in steps of 1 ms.

External Audio (RB-VHEDD8)

This selection shows the External Audio sub-menu. The sub-menu items are TERMINATION and SRC/CLOCK CONTROL.

Termination

This selection shows the Termination sub-menu. The sub-menu items are CHANNEL 1\2, CHANNEL 3\4, CHANNEL 5\6, CHANNEL 7\8 and DOLBY OUTPUT.

Channel 1\2, 3\4, 5\6, 7\8 and Dolby Output

These options select the termination for each of the external digital audio connections. The available options are 75 OHM and 110 OHM.

- 75 Ohm – The digital audio connection is set 75 ohm (AES 3ID) termination.
- 110 Ohm – The digital audio connection is set to 110 ohm (AES3) termination.

SRC/CLK Control

This selection shows the SRC/CLK Control sub-menu. The sub-menu items are CH1\2 SRC, CH3\4 SRC, CH5\6 SYNC and CH7\8 SYNC.

When the external inputs are required to be directly embedded into the video stream (before entering the encoder) the sources must be synchronous to the video clock. The first two external inputs, CH1\2 and CH3\4 have sample rate converters which ensure that the inputs are synchronous, but CH5\6 and CH7\8 inputs must be synchronous prior to being presented to the unit. When embedding these inputs, the synchronous clock setting must be set to ENABLE.

CH1\2 SRC, CH3\4 SRC

This option controls the sample rate conversion function on the CH1\2 and CH3\4 external inputs. The available options are DISABLE and ENABLE.

- DISABLE – The SRC is disabled.
- ENABLE – The SRC is enabled.



CH5\6 Sync, CH7\8 Sync

This option informs the unit that these inputs are synchronous to the video clock. The available options are DISABLE and ENABLE.

- **DISABLE** – The external input connection is NOT synchronous to the video clock. These channels should not be embedded directly into the video stream.
- **ENABLE** – The external input connection IS synchronous to the video clock. These inputs can be embedded directly into the video stream.

External Audio (RB-VHDDD8)

This selection shows the External Audio sub-menu. The sub-menu items are SOURCE SELECT and TERMINATION.

Source Select

This selection shows the Source Select sub-menu. This sub-menu selects the source for each external output channel. The sources can be selected to come from either the decoder outputs or the de-embedder block. All selections are post level control.

Termination

This selection shows the Termination sub-menu. The sub-menu items are **CHANNEL 1\2, CHANNEL 3\4, CHANNEL 5\6, CHANNEL 7\8, DOLBY OUTPUT** and **AUX**.

Channel 1\2, 3\4, 5\6, 7\8, Dolby Output and Aux

These options select the termination for each of the external digital audio connections. The available options are 75 OHM and 110 OHM.

- **75 Ohm** – The digital audio connection is set to 75 ohm (AES 3ID) termination.
- **110 Ohm** – The digital audio connection is set to 110 ohm (AES3) termination.

Embed

This selection shows the Embed sub-menu. Embedding is controlled on a per SDI output basis, so each SDI output is completely independent of the other after the de-embedding process. For example, you may wish to have one SDI output as a re-clocked version of the input with all ancillary data passed through with no changes made and the second output can be used as the “new” output with embedding and deletion options applied to this output only.

The **RB-VHEDD8** can use the encoder inputs, encoded output and the de-embedder outputs as audio sources for embedding. The sub-menu items are SDI OUTPUT 1 and SDI OUTPUT 2.

The **RB-VHDDD8** can use both the decoder outputs and the de-embedder outputs as audio sources for embedding. This allows for maximum flexibility. For example, the incoming SDI video may have a Dolby E bitstream being carried on group 1 channel pair 1. This can be selected as the source for the decoder and then be re-embedded into the same group and channel pair along with the downmix output from the decoder embedded into channel pair 2.



SDI Output 1 and 2

These selections show the Output Embed sub-menu. It allows control for embedding to the selected SDI output. The sub-menu items are GROUP 1, GROUP 2, GROUP 3, GROUP 4 and SD 24-BIT.

Group 1, 2, 3 and 4

These selections show the Group Embed sub-menu. The sub-menu items are EMBED, CHANNEL 1, CHANNEL 2, CHANNEL 3 and CHANNEL 4.

SD 24-Bit

This option controls the embedding of extended data packets in the SD video formats, to allow for full 24-bit embedding. Before enabling this option, ensure that any receiving equipment is capable of handling the extended data packets.

- DISABLE – Extended data packets are disabled. 20-bit embedding in SD formats.
- ENABLE – Extended data packets are enabled for full 24-bit embedding in SD formats.

Embed

This option controls embedding of the selected group to the selected SDI output. Available options are DISABLE, ENABLE.

- DISABLE – Embedding is disabled.
- ENABLE – Embedding is enabled to the selected group. If this group is detected on the incoming video, it is replaced with the new group.

Channel 1, 2, 3 and 4 (RB-VHEDD8)

This option allows selection of the channel source for the currently selected channel within a group.

The sources from the de-embedder block are labeled de-embedder, with the group number prefixed with G and the the channel number prefixed with C. For example, channel 2 from group 3 will be labeled as DE-EMBEDDER G3C2.

- DE-EMBEDDER G1C1 – De-embedder group 1 channel 1.
- DE-EMBEDDER G1C2 – De-embedder group 1 channel 2.
- DE-EMBEDDER G1C3 – De-embedder group 1 channel 3.
- DE-EMBEDDER G1C4 – De-embedder group 1 channel 4.
- DE-EMBEDDER G2C1 – De-embedder group 2 channel 1.
- DE-EMBEDDER G2C2 – De-embedder group 2 channel 2.
- DE-EMBEDDER G2C3 – De-embedder group 2 channel 3.



- DE-EMBEDDER G1C4 – De-embedder group 2 channel 4.
- DE-EMBEDDER G1C1 – De-embedder group 3 channel 1.
- DE-EMBEDDER G1C2 – De-embedder group 3 channel 2.
- DE-EMBEDDER G1C3 – De-embedder group 3 channel 3.
- DE-EMBEDDER G1C4 – De-embedder group 3 channel 4.
- DE-EMBEDDER G1C1 – De-embedder group 4 channel 1.
- DE-EMBEDDER G1C2 – De-embedder group 4 channel 2.
- DE-EMBEDDER G1C3 – De-embedder group 4 channel 3.
- DE-EMBEDDER G1C4 – De-embedder group 4 channel 4.

When selecting the external inputs 1-4 as sources for the embedder block, the SRCs must be enabled if the sources are not synchronous. For external inputs 5-8, if the sources are not synchronous they must not be embedded into the video stream, and can only be used as sources for the encoder inputs.

- EXT. INPUT CH1
- EXT. INPUT CH2
- EXT. INPUT CH3
- EXT. INPUT CH4
- EXT. INPUT CH5
- EXT. INPUT CH6
- EXT. INPUT CH7
- EXT. INPUT CH8

Dolby channels 1-2 are the output bitstream from the encoder, these channels must be embedded in a channel pair together, with DOLBY CH1 in channel 1 or 3, and DOLBY CH2 in channel 2 or 4, respectively.

- DOLBY CH1
- DOLBY CH2
- MUTED



1

INTRODUCTION



INTRODUCTION

Channel 1, 2, 3 and 4 (RB-VHDDD8)

This option allows selection of the channel source for the currently selected channel within a group.

The sources from the de-embedder block are labeled de-embedder, with the group number prefixed with G and the the channel number prefixed with C. For example, channel 2 from group 3 will be labeled as DE-EMBEDDER G3C2.

- DE-EMBEDDER G1C1 – De-embedder group 1 channel 1.
- DE-EMBEDDER G1C2 – De-embedder group 1 channel 2.
- DE-EMBEDDER G1C3 – De-embedder group 1 channel 3.
- DE-EMBEDDER G1C4 – De-embedder group 1 channel 4.
- DE-EMBEDDER G2C1 – De-embedder group 2 channel 1.
- DE-EMBEDDER G2C2 – De-embedder group 2 channel 2.
- DE-EMBEDDER G2C3 – De-embedder group 2 channel 3.
- DE-EMBEDDER G2C4 – De-embedder group 2 channel 4.
- DE-EMBEDDER G3C1 – De-embedder group 3 channel 1.
- DE-EMBEDDER G3C2 – De-embedder group 3 channel 2.
- DE-EMBEDDER G3C3 – De-embedder group 3 channel 3.
- DE-EMBEDDER G3C4 – De-embedder group 3 channel 4.
- DE-EMBEDDER G4C1 – De-embedder group 4 channel 1.
- DE-EMBEDDER G4C2 – De-embedder group 4 channel 2.
- DE-EMBEDDER G4C3 – De-embedder group 4 channel 3.
- DE-EMBEDDER G4C4 – De-embedder group 4 channel 4.
- DECODER OUTPUT CH1
- DECODER OUTPUT CH2
- DECODER OUTPUT CH3
- DECODER OUTPUT CH4
- DECODER OUTPUT CH5
- DECODER OUTPUT CH6
- DECODER OUTPUT CH7



- DECODER OUTPUT CH8
- DECODER AUX. CH1
- DECODER AUX CH2.
- MUTED

VANC Metadata (RB-VHDDD8)

This selection shows the VANC Metadata sub-menu. This controls the embedding of the metadata output from the decoder within the VANC area of the selected SDI output. The sub-menu items are EMBED and CHANNEL PAIR.

Embed

This options enables or disables embedding of metadata. The available options are DISABLE and ENABLE.

Channel Pair

This options assigns the VANC metadata to a selected channel pair. The available options are NONE, CHANNELS 1\2, CHANNELS 3\4, CHANNELS 5\6, CHANNELS 7\8, CHANNELS 9\10, CHANNELS 11\12, CHANNELS 13\14 and CHANNELS 15\16. The default selection is NONE.

Audio Delete

This selection shows the Audio Delete sub-menu. This sub-menu controls the deletion of the audio groups from the incoming video stream. Audio deletion can be set independently on both of the SDI outputs. The sub-menu items are SDI OUTPUT 1 and SDI OUTPUT 2.

SDI Output 1 and 2

These selections show the Output Group Delete sub-menu. It allows control of audio deletion on the selected SDI output. The sub-menu items are GROUP 1, GROUP 2, GROUP 3 and GROUP 4.

Group 1, 2, 3 and 4

These options enable or disable audio group deletion on the selected group and SDI output path. The available options are DISABLE and ENABLE.

- DISABLE – Disables the deletion of the selected audio group.
- ENABLE – Enable the deletion of the selected audio group.

Level Control (RB-VHEDD8)

This selection shows the Level Control sub-menu. It provides control of the audio levels of the external inputs and the de-embedder channels. Each channel can be independently adjusted from -24dB through to +24dB in 0.5dB steps. The sub-menu items are EXTERNAL INPUTS and DE-EMBEDDER. The default value for all the channels is 0 dB.

External Inputs

This selection lists the external inputs. Selecting a channel will allow editing of the level for that channel.





De-embedder

This selection lists the de-embedder channels. Selecting a channel will allow editing of the level for that channel.

Level Control (RB-VHDDD8)

This selection shows the level control sub-menu. It provides control of the audio levels of the decoder outputs and de-embedder channels. Each channel can be independently adjusted from -24dBn through to +24dBn in 0.5dB steps. The sub-menu items are **DECODER OUTPUTS** and **DE-EMBEDDER**.

Decoder Outputs

This selection lists the external inputs. Selecting a channel will allow editing of the level for that channel.

De-embedder

This selection lists the de-embedder channels. Selecting a channel will allow editing of the level for that channel.

Remote Outputs

This selection shows the Remote Outputs sub-menu. The sub-menu items list **OUTPUT 1** to **OUTPUT 8**.

Output 1-8

This selection shows the selected Output sub-menu. The sub-menu items are **POLARITY**, **ACTION** and **EVENT**.

Polarity

This option sets the polarity of the selected remote output. The available options are **NORMALLY ACTIVE** and **NORMALLY INACTIVE**.

- Normally Active - The remote output is normally in an active state, when the remote output is triggered the output goes inactive.
- Normally Inactive - The remote output is normally in an inactive state. When the remote output is triggered, the output goes active.

Action

This option sets the action type of the selected remote output. The available options are **MOMENTARY** and **LATCHED**.

- Momentary - When the remote output is triggered, the output is activated for half a second and then returns to its normal state.
- Latched - When the remote output is triggered, the output is activated, and remains active until the event state is removed.

Event (RB-VHEDD8)

This option sets the triggering event of the selected remote output. The available options are **NONE**, **SDI UNLOCK**, **ENCODING ERROR**, **EXTERNAL/VANC METADATA**, **ENCODING STOPPED**.



- None – No event triggers the remote output. It remains in it's normal state.
- SDI Unlock – The SDI input is removed, or the signal is lost.
- Encoding Error – There is an encoding error. Such as an invalid metadata source or incorrect frame rate selection.
- External/VANC Metadata – The external/VANC metadata is removed, invalid or the signal is lost.
- Encoding Stopped – The encoding process is stopped.



Event (RB-VHDD8)

This option sets the triggering event of the selected remote output. The available options are NONE, SDI UNLOCK, DECODING ERROR, DECODING DOLBY E, DECODING DOLBY DIGITAL and PCM BYPASS.

- None – No event triggers the remote output. It remains in it's normal state.
- SDI Unlock – The SDI input is removed, or the signal is lost.
- Decoding Error – There is an decoding error.
- Decoding Dolby E – The decoder is receiving a Dolby E bitstream.
- Decoding Dolby Digital – The decoder is receiving a Dolby Digital bitstream.
- PCM Bypass – The decoder is receiving a PCM bitstream.

System

Front Panel Lock

This option allows the front panel rotary controls to be disabled. From the main system menu select CONTROL LOCK. The available options are OFF and ON. Access to the system menu is still enabled when the control lock is on to allow the lock to be removed. When the control lock is enabled, a small key icon is displayed in the upper right side of the main screen display. When selected, this control disables the front panel and prohibits any changes to be made via the front panel. This control is automatically disabled when the unit is powered on.

Network

DHCP

This option is used to enable or disable the DHCP client in the unit. Enabling the DHCP will cause the Network interface to restart and disconnect any client connections to the unit. The unit will then attempt to retrieve a valid IP address from a DHCP server. If the DHCP client is disabled then this will disconnect any client connections to the unit and revert to the static network settings stored in the unit.



Static Settings

These are the static network settings used when DHCP is not enabled.

Status

Displays the current network address information currently in use by the unit, along with the physical address of the network interface.

Factory Reset

This menu selection is used to reset all control parameters to their default settings. Excluding the network configuration settings. Once completed, this operation cannot be undone.

Information

This selection shows product and software version information. From the system sub-menu select **INFORMATION**.

Product: This is set to RB-VHDDD8/RB-VHEDD8. This is used to identify the unit when using a PC and the Redbox control software.

Serial No: The Serial Number is factory set. Always quote this number in any correspondence with Sonifex technical support.

Firmware/FPGA/Display/AIM: These are the versions of firmware contained in the unit. This software can be upgraded. For the latest software updates, check the Sonifex website at www.sonifex.co.uk

Dolby : This is the current version of firmware in the Dolby Encoder or Decoder card.



SCI

SCI, the Serial Control Interface allows you to control the RB-VHDDD8 & RB-VHEDD8 units remotely. The interface has various pages available to configure and control the unit and also view the current status of the unit.

The status of the connection, IP address, serial number and firmware versions are always visible at the bottom of the interface.

When connecting to the unit, you will be asked for a user name and password. This is to restrict control (write) access to the unit to a single user. While other users can connect to the same unit, only one is allowed write access. By default, the user name is set to **admin** and the password is set to **admin**. These can be changed by the drop down menu in the top right hand corner of the screen, and are case sensitive. NOTE: Performing a factory reset on the unit, will reset these back to their default values.

If the login attempt fails, this maybe because either the unit is currently being controlled from another PC or the login details were incorrect. SCI will continue to operate in read-only mode until you disconnect.



SCI



Fig 2-1: SCI Login Screen.



RB-VHEDD8 System Screen

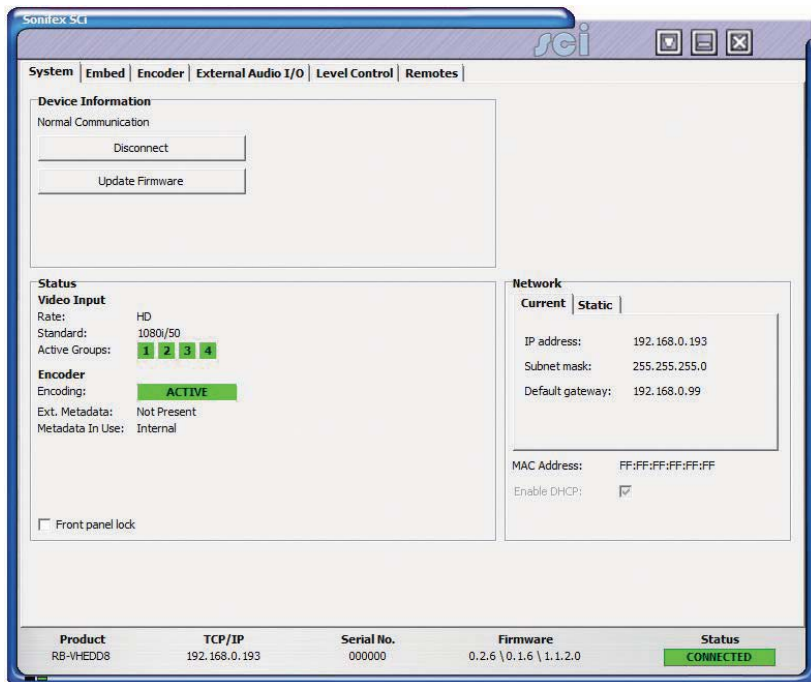

Fig 2-2: RB-VHEDD8 System Screen.

Disconnect/Connect

Use this button to connect or disconnect SCi to the unit.

Update Firmware

The firmware will occasionally be updated to add new features or correct any possible issues that may arise. Check for updates at: <http://www.sonifex.co.uk/technical/software>

To update the firmware click on the button labeled “Update Firmware” and then select the downloaded firmware file. Firmware files will have an “.dwn” extension.

A progress bar will appear in SCi, indicating the progress of the update. Once complete, the unit will need to be powered off and on for the update to take effect.

Status

Shows the status of the SDI input and the encoder.

The SDI input status displays the input rate, video format and active audio groups detected. If no video input is detected, then the rate and standard will both display N/A.



The encoder status displays the encoding status, this can be either ACTIVE, STOPPED or BYPASS. It also displays the state of the external metadata input and the metadata currently in use.

Front Panel Lock

When selected, this control disables the front panel and prohibits any changes to be made via the front panel. This control is automatically disabled when the unit is powered on.

Network

This displays the current settings and status of the network connection on the unit.

Enable DHCP: This enables the unit to receive its IP address, subnet mask and gateway settings from a DHCP server. If one is not available then this should be disabled through the serial port and a valid static address be entered. This option cannot be set via SCI and must be set via the front panel of the unit.

Selecting the CURRENT page displays the network address in use by the unit.

IP Address: Displays the current IP address of the unit (this is also displayed on the bottom of the screen). If DHCP is enabled then this will normally be the IP address supplied by the DHCP server.

Subnet Mask: Displays the current subnet mask for the unit.

Default gateway: Displays the current default gateway for the unit.

MAC Address: The unit's MAC address. This cannot be changed.

Selecting the STATIC page displays the static network address stored in the unit. This address is used when the DHCP is disabled.

Note: The units are discovered using broadcast packets. If your PC has two network cards, then there is a limitation in windows that requires the two addresses to be on different subnet addresses.



SCI



RB-VHDDD8 System Screen

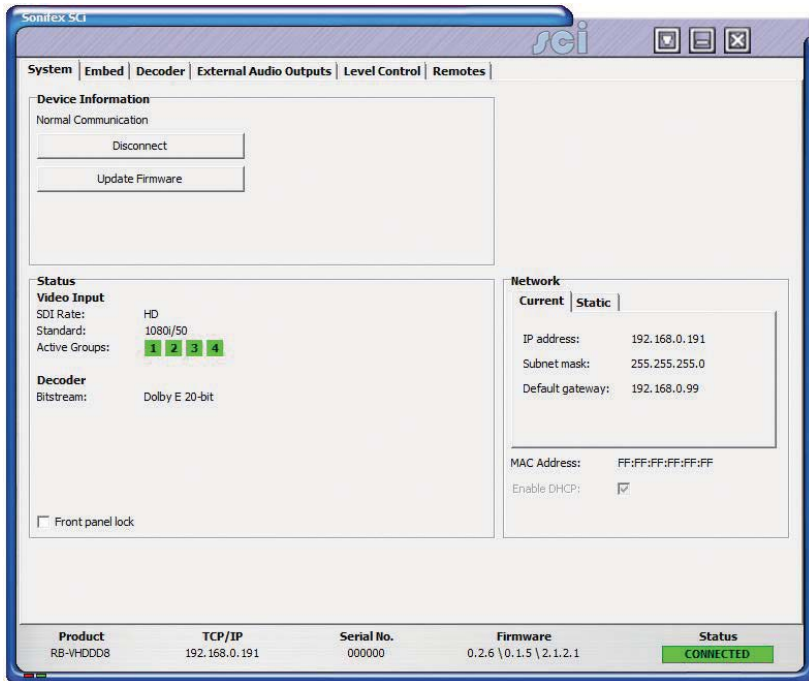

Fig 2-3: RB-VHDDD8 System Screen.

Disconnect/Connect

Use this button to connect or disconnect SCI to the unit.

Update Firmware

The firmware will occasionally be updated to add new features or correct any possible issues that may arise. Check for updates at: <http://www.sonifex.co.uk/technical/software>

To update the firmware click on the button labeled "Update Firmware" and then select the downloaded firmware file. Firmware files will have an ".dwn" extension.

A progress bar will appear in Sci, indicating the progress of the update. Once complete, the unit will need to be powered off and on for the update to take effect.

Status

Shows the status of the SDI input and the encoder.

The SDI input status displays the input rate, video format and active audio groups detected. If no video input is detected, then the rate and standard will both display N/A.

The decoder status displays the bitstream currently being decoded by the unit.



SCI

Network

This displays the current settings and status of the network connection on the unit.

Enable DHCP: This enables the unit to receive its IP address, subnet mask and gateway settings from a DHCP server. If one is not available then this should be disabled through the serial port and a valid static address be entered. This option cannot be set via SCI and must be set via the front panel of the unit.

Selecting the CURRENT page displays the network address in use by the unit.

IP Address: Displays the current IP address of the unit (this is also displayed on the bottom of the screen). If DHCP is enabled then this will normally be the IP address supplied by the DHCP server.

Subnet Mask: Displays the current subnet mask for the unit.

Default gateway: Displays the current default gateway for the unit.

MAC Address: The unit's MAC address. This cannot be changed.

Selecting the STATIC page displays the static network address stored in the unit. This address is used when the DHCP is disabled.

Note: The units are discovered using broadcast packets. If your PC has two network cards, then there is a limitation in windows that requires the two addresses to be on different subnet addresses.



Embed

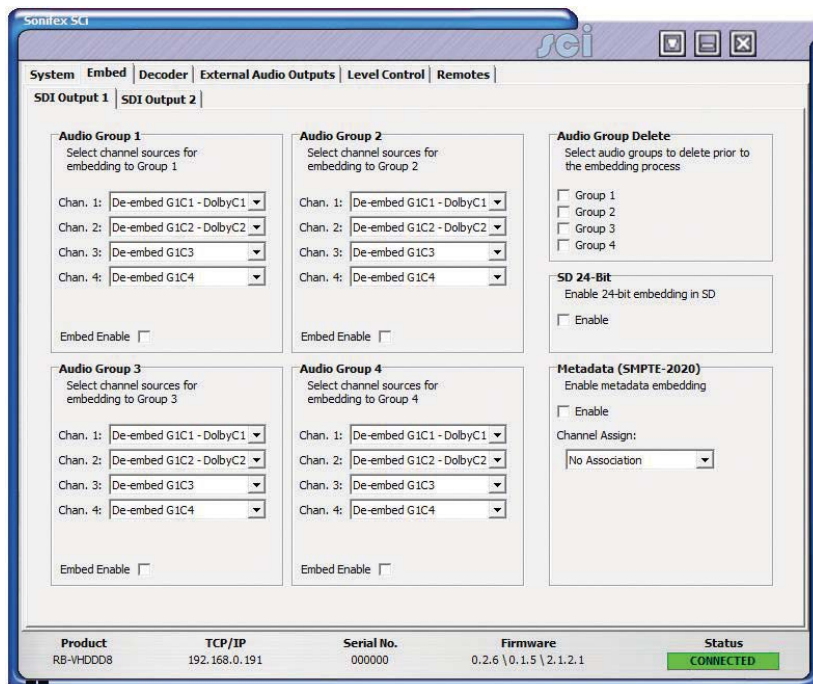

Fig 2-4: RB-VHDD8 Embed Screen.

This screen controls all the embedding options available within the unit. These controls are applied to the SDI output selected using the tab control at the top of the page. To control embedding on SDI output 1 select SDI Output 1 page, to control embedding on SDI output 2 select SDI Output 2 page.

Audio Groups

There are 4 channels available in each group. The source for these channels can be selected using the drop down boxes associated with each of the channels.

Embed Enable: Selecting this check box, enables embedding to relevant group. Deselecting this check box disables embedding.

Audio Group Delete

Allows the deletion of audio groups. Simply select the required group to enable deletion.

SD 24-Bit

This enables 24-bit embedding in SD. This is selectable on a per output basis. Before enabling this option, ensure that any receiving equipment is capable of handling the extended data packets.



Metadata (SMPTE-2020) - RB-VHDDD8 Only

Enables/disables embedding of the metadata output from the decoder.

Channel Assign: Assigns the metadata to a channel pair within the video output.

Encoder (RB-VHEDD8)

Provides control over the encoding process, the metadata settings and also displays the current metadata output status. For more information on these controls, see the ENCODER CONTROL section of the manual.

Control

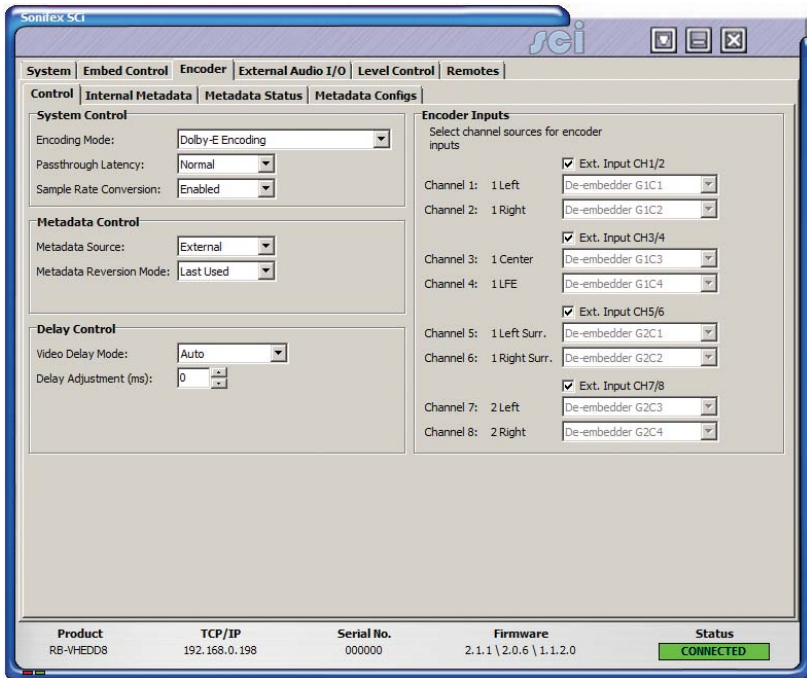

Fig 2-5: RB-VHEDD8 Encoder Control Screen.

These controls replicate those available from the ENCODER CONTROL menu via the front panel display. For more information on these settings see the relevant section of the manual.



Metadata Control

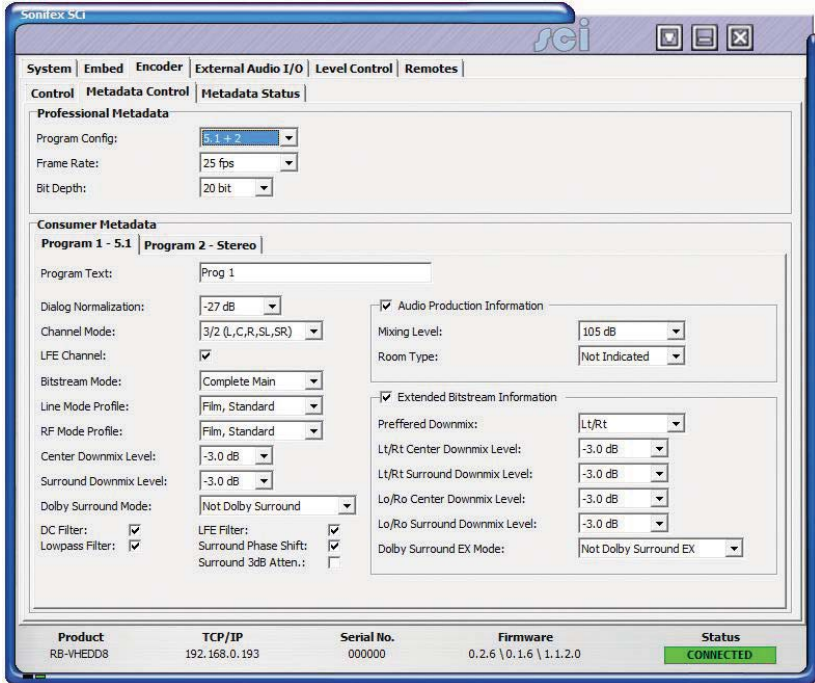

Fig 2-6: RB-VHEDD8 Encoder Meta Control Screen.

This page allows the setting of all the INTERNAL metadata settings, including the professional metadata and consumer metadata for all of the available programs.



Metadata Status

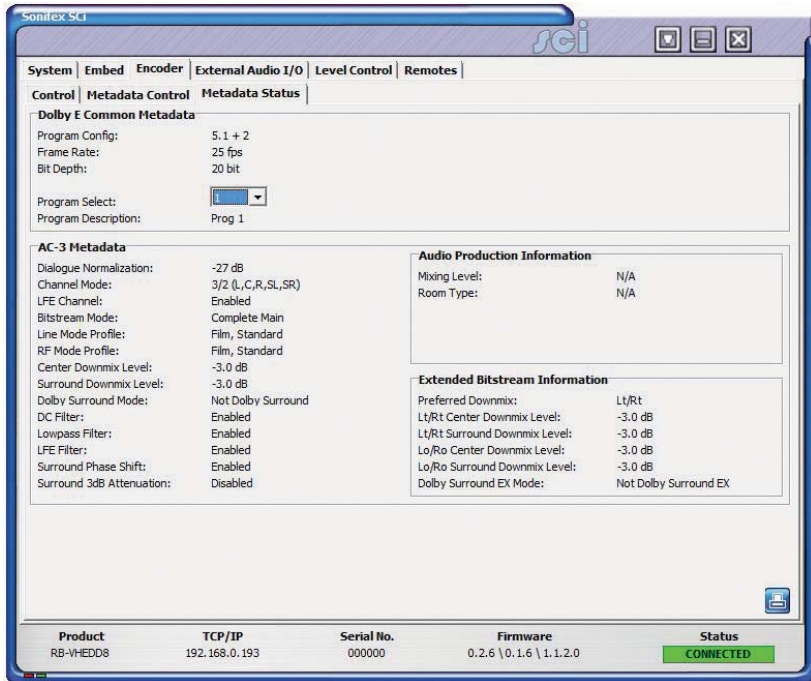

Fig 2-7: RB-VHEDD8 Encoder Meta Status Screen.

This status page displays the metadata currently in use by the encoder. The professional metadata is display at the top with the program AC-3 metadata displayed in the lower box. Use the program select drop down box to determine which program metadata is viewable.



Decoder (RB-VHDDD8)

Control

These controls replicate those available from the DECODER CONTROL menu via the front panel display. For more information on these settings see the relevant section of the manual.

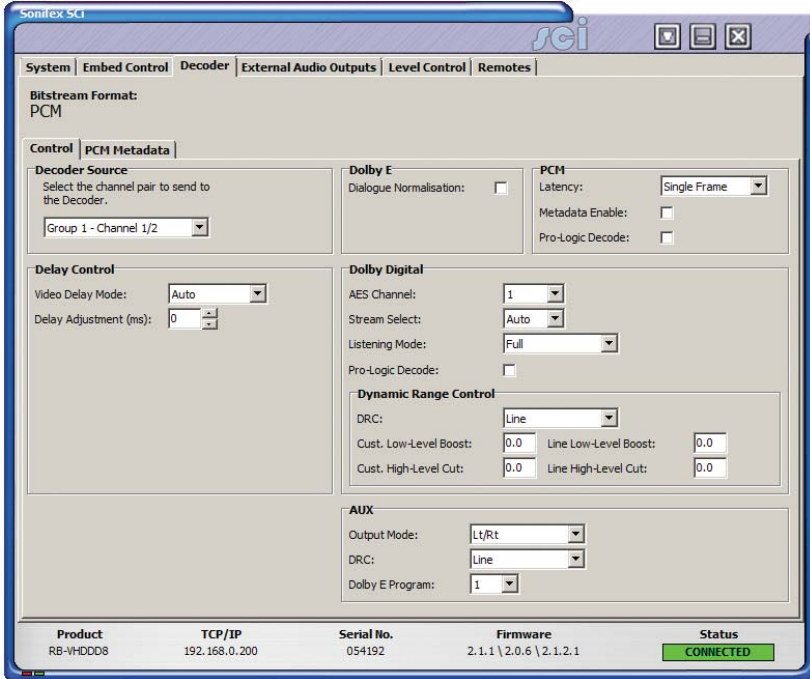

Fig 2-8: RB-VHDDD8 Decoder Control Screen.



PCM Metadata

These controls replicate those available from the PCM METADATA menu via the front panel display. For more information on these settings see the relevant section of the manual.

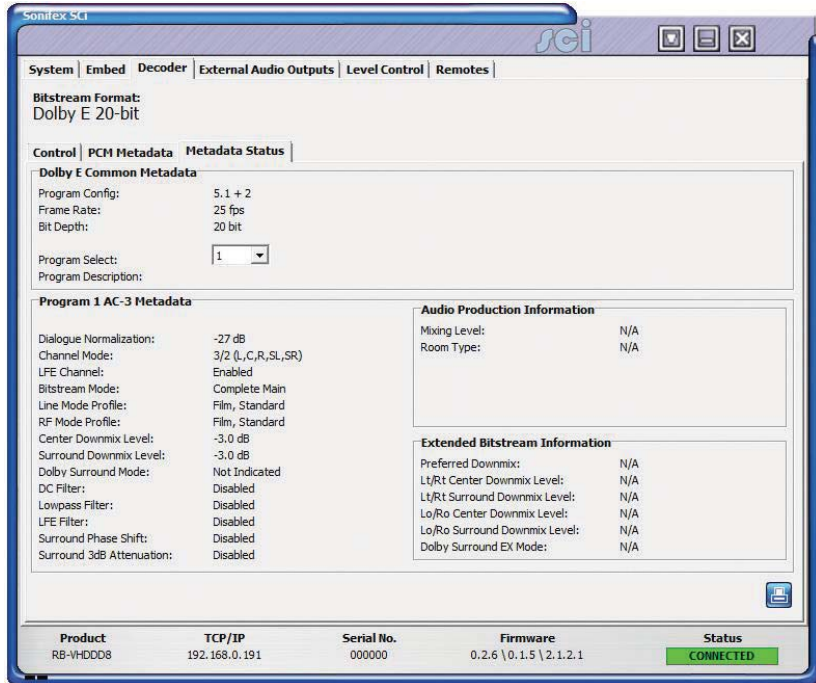

Fig 2-9: RB-VHDDD8 Decoder PCM Metadata Screen.



Metadata Status

This page displays the metadata information obtained from the decoded bitstream. For Dolby E bitstreams, the professional metadata is displayed at the top with the program AC-3 metadata displayed in the lower box. Use the program select drop down box to determine which program metadata is viewable. For Dolby Digital bitstreams only the AC-3 metadata box is shown. This page is not available when receiving a PCM bitstream.

System | Embed | Decoder | External Audio Outputs | Level Control | Remotes

Bitstream Format:
Dolby E 20-bit

Control | PCM Metadata | Metadata Status

Dolby E Common Metadata

Program Config: 5.1 + 2
 Frame Rate: 25 fps
 Bit Depth: 20 bit
 Program Select: 1
 Program Description:

Program 1 AC-3 Metadata

Dialogue Normalization: -27 dB
 Channel Mode: 3/2 (L, C, R, SL, SR)
 LFE Channel: Enabled
 Bitstream Mode: Complete Main
 Line Mode Profile: Film, Standard
 RF Mode Profile: Film, Standard
 Center Downmix Level: -3.0 dB
 Surround Downmix Level: -3.0 dB
 Dolby Surround Mode: Not Indicated
 DC Filter: Disabled
 Lowpass Filter: Disabled
 LFE Filter: Disabled
 Surround Phase Shift: Disabled
 Surround 3dB Attenuation: Disabled

Audio Production Information

Mixing Level: N/A
 Room Type: N/A

Extended Bitstream Information

Preferred Downmix: N/A
 Lt/Rt Center Downmix Level: N/A
 Lt/Rt Surround Downmix Level: N/A
 Lo/Ro Center Downmix Level: N/A
 Lo/Ro Surround Downmix Level: N/A
 Dolby Surround EX Mode: N/A

Product RB-VHDDD8 **TCP/IP** 192.168.0.191 **Serial No.** 000000 **Firmware** 0.2.6 \ 0.1.5 \ 2.1.2.1 **Status** **CONNECTED**

Fig 2-10: RB-VHDDD8 Decoder Metadata Status Screen.



External Audio I/O (RB-VHEDD8)

This page controls the external audio. For more information on these controls, see the EXTERNAL AUDIO section of the manual.

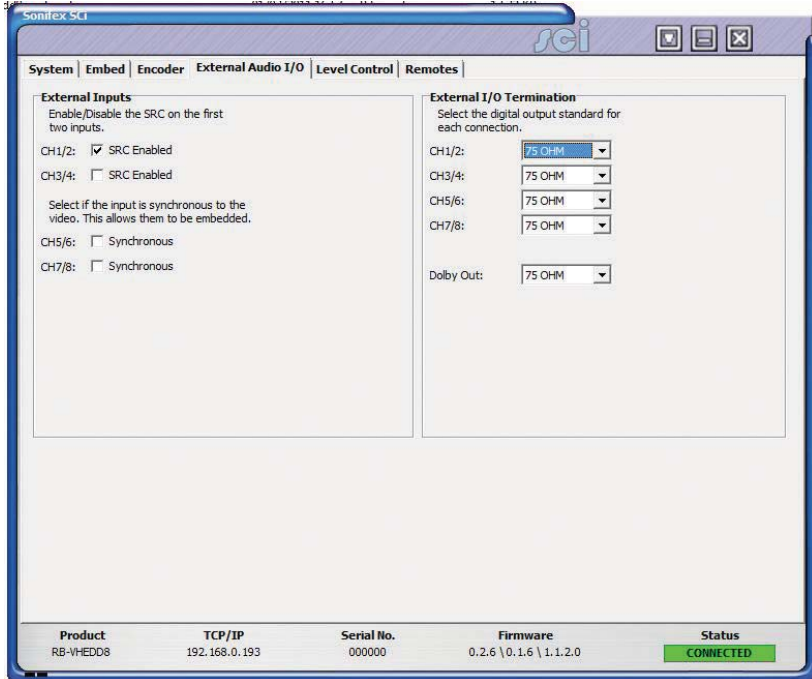

Fig 2-11: RB-VHEDD8 External Audio Screen.



SCI



External Audio Outputs (RB-VHDDDD8)

These controls replicate those available from the EXTERNAL AUDIO menu via the front panel display. For more information on these settings see the relevant section of the manual.

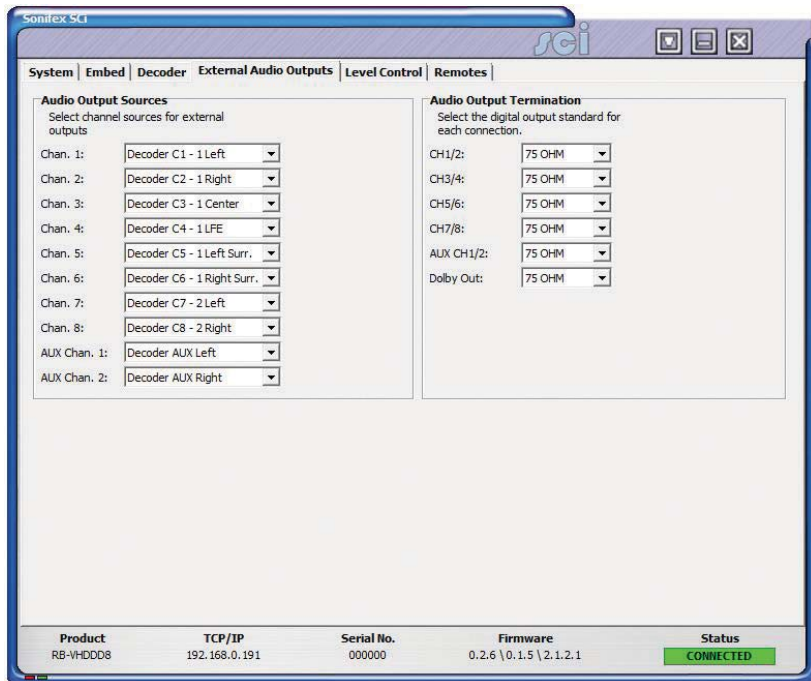

Fig 2-12: RB-VHDDDD8 External Audio Screen.



Level Control

This page provides control of the audio levels of the de-embedder channels and the external inputs for the RB-VHEDD8 or the decoder outputs for the RB-VHDDD8. Each channel can independently adjusted from -24dB through to +24dB in 0.5dB steps. Selecting the LINK check box moves all the volume faders together in that group. Double-clicking the gain value will set that channel back to unity gain (0dB).

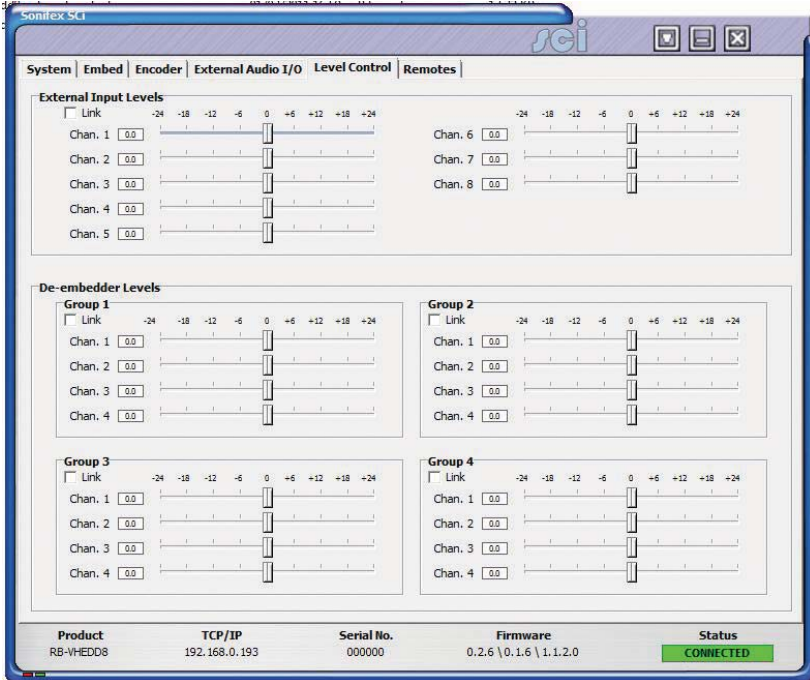

Fig 2-13: RB-VHEDD8 Level Screen.



SCI



The screenshot displays the 'Level Control' interface of the Sonifex SCI. It features a top navigation bar with tabs for 'System', 'Embed', 'Decoder', 'External Audio Outputs', 'Level Control', and 'Remotes'. The 'Level Control' tab is active, showing two main sections: 'Decoder Levels' and 'De-embedder Levels'.

Decoder Levels: This section contains two columns of sliders. The left column includes '1 Left', '1 Right', '1 Center', '1 LFE', and '1 Left Surr.'. The right column includes '1 Right Surr.', '2 Left', '2 Right', 'AUX Left', and 'AUX Right'. Each slider has a numerical display (all set to 0.0) and a scale from -24 to +24.

De-embedder Levels: This section contains four groups of sliders, labeled 'Group 1' through 'Group 4'. Each group has a 'Link' checkbox and four channels (Chan. 1 to Chan. 4). Each channel has a numerical display (all set to 0.0) and a scale from -24 to +24.

System Information: At the bottom, a status bar displays the following data:

Product	TCP/IP	Serial No.	Firmware	Status
RB-VHDD8	192.168.0.191	000000	0.2.6 \ 0.1.5 \ 2.1.2.1	CONNECTED

Fig 2-14: RB-VHDD8 Level Screen.



Remotes

This page provides control over all the remote outputs in the unit. For more information on these, see the REMOTE OUTPUTS section of the manual.

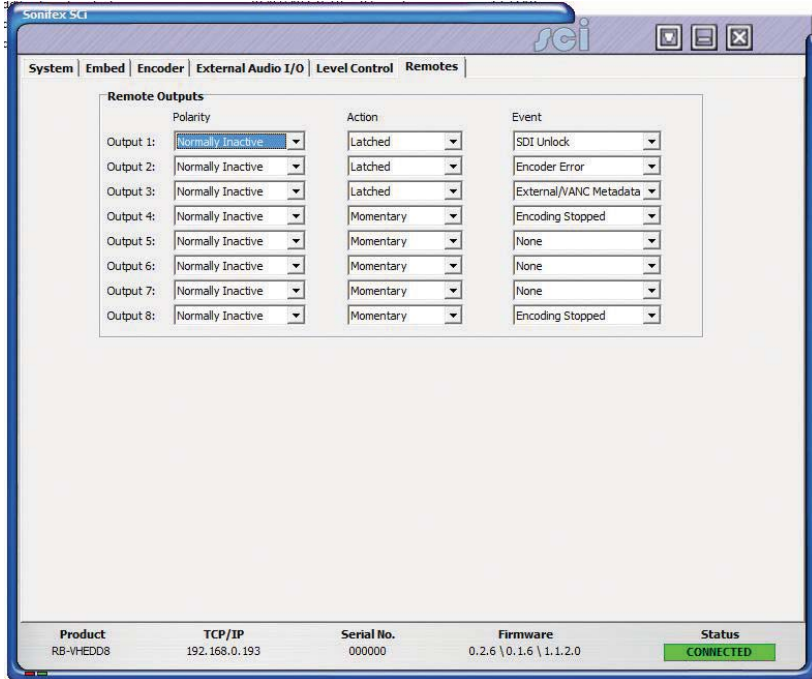

Fig 2-15: RB-VHEDD8 Remotes Screen.



The screenshot shows the 'Remotes' configuration page in the Sonifex SCI web interface. The page has a blue header with the 'sci' logo and standard window controls. A navigation menu at the top includes 'System', 'Embed', 'Decoder', 'External Audio Outputs', 'Level Control', and 'Remotes'. The main content area is titled 'Remote Outputs' and contains a table with the following columns: Output, Polarity, Action, and Event. The table lists 8 outputs, all with 'Normally Inactive' polarity and 'Latched' action, and 'None' event. At the bottom, a status bar displays system information: Product (RB-VHDD8), TCP/IP (192.168.0.191), Serial No. (000000), Firmware (0.2.6 \ 0.1.5 \ 2.1.2.1), and Status (CONNECTED).

Output	Polarity	Action	Event
Output 1:	Normally Inactive	Latched	None
Output 2:	Normally Inactive	Latched	None
Output 3:	Normally Inactive	Latched	None
Output 4:	Normally Inactive	Latched	None
Output 5:	Normally Inactive	Latched	None
Output 6:	Normally Inactive	Latched	None
Output 7:	Normally Inactive	Latched	None
Output 8:	Normally Inactive	Latched	None

Product RB-VHDD8
 TCP/IP 192.168.0.191
 Serial No. 000000
 Firmware 0.2.6 \ 0.1.5 \ 2.1.2.1
 Status CONNECTED

Fig 2-16: RB-VHDD8 Remotes Screen.

Technical Specification

SDI Specification

SDI Input:	1 x BNC, 3G/HD/SD-SDI
SDI Outputs:	2 x BNC, 3G/HD/SD-SDI, re-clocked
Impedance:	75Ω
Output Alignment Jitter:	<0.2UI (3G <0.3UI)
Output Level:	800mV ±10%
Return Loss:	<15dB at 1500MHz
SDI Supported Standards:	270Mbps, SMPTE-259M-C (SD) 1.485 or 1.4835Gbps, SMPTE-292M (HD) 2.97 or 2.967Gbps, SMPTE-424M (3G), SMPTE-425M-A
Supported Video Formats:	525/59.94 (SMPTE-125M) 625/50 (ITU-R BT.656) 720p/23.98, 24, 25, 29.97, 30, 50, 59.94, 60 (SMPTE-296M) 1035i/59.94, 60 (SMPTE-260M) 1080i/50, 59.94, 60 (SMPTE-274M) 1080p/23.98, 24, 25, 50, 59.94, 60 (SMPTE-274M) 1080pSF/23.98, 24, 25, 29.97, 30 (RP-211) 1080i/50 (SMPTE-295M) 1080p/50 (SMPTE-295M)
Embedded Audio:	24-bit, 48kHz synchronous SMPTE-272M-C SMPTE-299M
Metadata:	SMPTE-2020M SMPTE-RDD06, 9-Pin D-type

Delay Specification

Video Delay:	1 frame when frame rate ≤ 30 fps, 2 frames when frame rate > 30 fps.
Adjustment:	+/- 10 ms.

Audio Specifications (RB-VHDDDD8)

Output Sample Rate:	48kHz
Output Impedance:	75Ω/110Ω selectable



TECHNICAL SPECIFICATION

3

TECHNICAL SPECIFICATION



TECHNICAL SPECIFICATION

Signal Level: Unbalanced: 1Vp-p +/- 20%
(un-terminated) Balanced: 6.4Vp-p +/- 20%

Digital Audio Outputs: 12 output channels via 6 x BNC or 25 way D-type socket (AES3)

Digital Audio Connectors: 6 x BNC
1x 25-way D-type socket

Audio Specifications (RB-VHEDD8)

Output Sample Rate: 48kHz

Input Sample Rates: CH1/2 & CH3/4: 32-192kHz
CH5/6 & CH7/8: 32-48kHz

Input & Output Impedance: 75Ω/110Ω selectable

Signal Level Unbalanced: 1Vp-p ±20%
(un-terminated): Balanced: 6.6Vp-p ±20%

Digital Audio I/O:

Inputs: 8 x digital audio input channels via
4 x BNCs or 25 way D-type socket (AES3)

Outputs: 2 output channels via 1 x BNC or 25 way D-type socket (AES3)

Digital Audio Connectors: 5 x BNC
1 x 25-way D-type socket LTC Input: 1 x BNC (not used)

Operational Control

Display: Vacuum fluorescent display

System Navigation: Rotary selector with integral push-switch

Additional Connections

Ethernet Port: 10/100Mbps, RJ-45

Remote Input/Output Port: 25-way 'D'-type socket

Power Supply: Universal filtered IEC, continuously rated 85-264VAC
@47-63Hz, fused

Fuse Rating: Anti-surge fuse 2A 20 x 5mm

Equipment Type

RB-VHDDD8	3G/HD/SD-SDI Dolby® E & Dolby Digital decoder
RB-VHEDD8	3G/HD/SD-SDI Dolby® E encoder

Accessories

RB-RK3	1U Rear panel rack kit for large Redboxes
--------	---

Physical Specifications

Dimensions (Raw):	48cm (W) x 10.8cm (D*)x 4.2cm (H) 19" (W) x 4.3" (D*) x 1.7" (H) (1U)
Dimensions (Boxed):	59cm (W) x 27.5cm (D) x 11cm (H) 23.2" (W) x 10.8" (D) x 4.3" (H)
Weight:	Nett: 1.8kg Gross: 2.3kg Nett: 4.0lb Gross: 5.1lb

* Note that this product is deeper than standard Redboxes





Appendix

The table below describes the channel assignments of the decoder/encoder channels related to the Program Configuration when encoding/decoding Dolby E.

Dolby E Program Configuration	Main Channel Assignments							
	CH1	CH2	CH3	CH4	CH5	CH6	CH7	CH8
5.1 + 2	1L	1R	1C	1LFE	1Ls	1Rs	2L	2R
5.1 + 2x1	1L	1R	1C	1LFE	1Ls	1Rs	2C	3C
4 + 4	1L	1R	1C	1S	2C	2S	2L	2R
4 + 2x2	1L	1R	1C	1S	3L	3R	2L	2R
4 + 2 + 2x1	1L	1R	1C	1S	3C	4C	2L	2R
4 + 4x1	1L	1R	1C	1S	4C	5C	2C	3C
4x2	1L	1R	3L	3R	4L	4R	2L	2R
3x2 + 2x1	1L	1R	3L	3R	4C	5C	2L	2R
2x2 + 4x1	1L	1R	3C	4C	5C	6C	2L	2R
2 + 6x1	1L	1R	4C	5C	6C	7C	2C	3C
8x1	1C	2C	3C	4C	5C	6C	7C	8C
5.1	1L	1R	1C	1LFE	1Ls	1Rs	NONE	NONE
4 + 2	1L	1R	1C	1S	NONE	NONE	2L	2R
4 + 2x1	1L	1R	1C	1S	NONE	NONE	2C	3C
3x2	1L	1R	3L	3R	NONE	NONE	2L	2R
2x2 + 2x1	1L	1R	3C	4C	NONE	NONE	2L	2R
2 + 4x1	1L	1R	4C	5C	NONE	NONE	2C	3C
6x1	1C	2C	3C	4C	5C	6C	NONE	NONE
4	1L	1R	1C	1S	NONE	NONE	NONE	NONE
2 + 2	1L	1R	NONE	NONE	NONE	NONE	2L	2R
2 + 2x1	1L	1R	NONE	NONE	NONE	NONE	2C	3C
4x1	1C	2C	3C	4C	NONE	NONE	NONE	NONE
7.1	1L	1R	1C	1LFE	1Ls	1Rs	1Bsl	1Bsr
7.1 Screen	1L	1R	1C	1LFE	1Ls	1Rs	1Le	1Re

The table below describes the channel assignments of the decoder channels related to the Coding Mode when decoding a Dolby Digital bitstream.

Dolby Digital Coding Mode	Main Channel Assignments							
	CH1	CH2	CH3	CH4	CH5	CH6	CH7	CH8
3/2L	1L	1R	1C	1LFE	1Ls	1Rs	NONE	NONE
3/2	1L	1R	1C	NONE	1Ls	1Rs	NONE	NONE
2/2L	1L	1R	NONE	1S	1Ls	1Rs	NONE	NONE
2/2	1L	1R	NONE	NONE	1Ls	1Rs	NONE	NONE
3/1L	1L	1R	1C	1LFE	1S	NONE	NONE	NONE
3/1_	1L	1R	1C	NONE	1S	NONE	NONE	NONE

2/1L	1L	1R	NONE	1LFE	1S	NONE	NONE	NONE
2/1_	1L	1R	NONE	NONE	1S	NONE	NONE	NONE
3/0L	1L	1R	3C	1LFE	NONE	NONE	NONE	NONE
3/0_	1L	1R	1C	NONE	NONE	NONE	NONE	NONE
2/0_	1L	1R	NONE	NONE	NONE	NONE	NONE	NONE
1/0_	NONE	NONE	1C	NONE	NONE	NONE	NONE	NONE
1+1	1C	2C	NONE	NONE	NONE	NONE	NONE	NONE
PCM	1L	1R	NONE	NONE	NONE	NONE	NONE	NONE

The table below describes the main channel output functions from the decoder relating to the selected Listening Mode, Dolby Pro Logic decode and Coding Mode when decoding a Dolby Digital bitstream.

Coding Mode	Dolby Pro Logic Decode	Listening Mode	Main Channel Output Function
3\2	Disable	Surround EX	All 3\2 channels + Dolby Digital Surround EX decoder of back surround
		Full	All 3\2 channels
		3 Stereo	3 Stereo downmix of 3\2 channels
		Phantom	Phantom downmix of 3\2 channels
		Stereo	Lo/Ro downmix
		Mono	Lo+Ro
	Enable	Surround EX	Default to Full mode
		Full	L, C, R, S from Lt/Rt downmix
		3 Stereo	3 Stereo from Lt/Rt
		Phantom	Phantom from Lt/Rt
		Stereo	Lt/Rt downmix
		Mono	Lt+Rt



4

APPENDIX



APPENDIX

2\2	Disable	Surround EX	All 2\2 channels + Surround EX decoder of back surround
		Full	All 2\2 channels
		3 Stereo	Default to 3 Stereo mode
		Phantom	Default to Full mode
		Stereo	Lo/Ro downmix
		Mono	Lo+Ro
	Enable	Surround EX	Default to Full mode
		Full	L, C, R, S from Lt/Rt downmix
		3 Stereo	3 Stereo from Lt/Rt
		Phantom	Phantom from Lt/Rt
		Stereo	Lt/Rt downmix
		Mono	Lt+Rt
3\1	Disable	Surround EX	Default to Full mode
		Full	All 3\1 channels
		3 Stereo	S mixed into L and R with smix coefficient
		Phantom	C mixed into L and R with cmix coefficient
		Stereo	Lo/Ro downmix
		Mono	Lo+Ro
	Enable	Surround EX	Default to Full mode
		Full	L, C, R, S from Lt/Rt downmix
		3 Stereo	3 Stereo from Lt/Rt
		Phantom	Phantom from Lt/Rt
		Stereo	Lt/Rt downmix
		Mono	Lt+Rt
2\1	Disable	Surround EX	Default to Full mode
		Full	All 2\1 channels
		3 Stereo	S mixed into L and R with smix coefficient
		Phantom	Default to Full mode
		Stereo	Lo/Ro downmix
		Mono	Lo+Ro
	Enable	Surround EX	Default to Full mode
		Full	L, C, R, S from Lt/Rt downmix
		3 Stereo	3 Stereo from Lt/Rt
		Phantom	Phantom from Lt/Rt
		Stereo	Lt/Rt downmix
		Mono	Lt+Rt



3\0	Disable	Surround EX	Default to 3 Stereo mode
		Full	Default to 3 Stereo mode
		3 Stereo	All 3\0 channels
		Phantom	C mixed into L and R with cmix coefficient
		Stereo	Lo/Ro downmix
		Mono	Lo+Ro
	Enable	Surround EX	Default to Full mode
		Full	L, C, R, S from Lt/Rt downmix
		3 Stereo	3 Stereo from Lt/Rt
		Phantom	Phantom from Lt/Rt
		Stereo	Lt/Rt downmix
		Mono	Lt+Rt
2\0	Disable	Surround EX	Default to Stereo mode
		Full	Default to Stereo mode
		3 Stereo	Default to Stereo mode
		Phantom	Default to Stereo mode
		Stereo	2\0 channels
		Mono	L+R
	Enable	Surround EX	Default to Full mode
		Full	L, C, R, S from 2/0 downmix
		3 Stereo	3 Stereo from 2/0 downmix
		Phantom	Phantom from 2/0 downmix
		Stereo	2/0 channels
		Mono	L+R
1\0	Disable	Surround EX	Default to Mono mode
		Full	Default to Mono mode
		3 Stereo	Default to Mono mode
		Phantom	Default to Mono mode
		Stereo	Default to Mono mode
		Mono	Mono center channel output
	Enable	Surround EX	Default to Mono mode
		Full	Default to Mono mode
		3 Stereo	Default to Mono mode
		Phantom	Default to Mono mode
		Stereo	Default to Mono mode
		Mono	Mono center channel output



1+1	Disable	Surround EX	Default to Stereo mode
		Full	Default to Stereo mode
		3 Stereo	Default to Stereo mode
		Phantom	Default to Stereo mode
		Stereo	L and R output
		Mono	L+R
	Enable	Surround EX	Default to Stereo mode
		Full	Default to Stereo mode
		3 Stereo	Default to Stereo mode
		Phantom	Default to Stereo mode
		Stereo	L and R output
		Mono	L+R

1. When a single Surround channel is present, it is attenuated and split into Ls and Rs.
2. 3 Stereo mode is either a Dolby Pro Logic® decoding mode (when Pro Logic is enabled), or a simple addition of surround channels into the front channels (when Pro Logic is disabled).



NOTES

NOTES



NOTES



NOTES



NOTES

SONIFEX

www.sonifex.co.uk

t:+44 (0)1933 650 700

f:+44 (0)1933 650 726

sales@sonifex.co.uk

