



HANDBOOK

Commentator Units

CM-CU1

Commentator Unit for 1 Commentator & Line Input

CM-CU21

Commentator Unit for 2 Commentators & 1 Guest



Manufacturers of audio & video
products for radio & TV broadcasters

SONIFEX

For the latest Sonifex handbook information please visit the
Sonifex website at www.sonifex.co.uk

This handbook is for use with the following product:

CM-CU1 Commentator Unit for 1 Commentator & Line Input

CM-CU21 Commentator Unit for 2 Commentators & 1 Guest

Stock Code: 30-239

Revision 2.03, March 2018

©Sonifex Ltd, 2018

All Rights Reserved

Sonifex Ltd, 61, Station Road, Irthlingborough,
Northants, NN9 5QE, England.

Tel: +44 (0)1933 650 700

Fax: +44 (0)1933 650 726

Email: sales@sonifex.co.uk

Website: <http://www.sonifex.co.uk>

Information in this document is subject to change without notice and does not represent a commitment on the part of the vendor. Sonifex Ltd shall not be liable for any loss or damage whatsoever arising from the use of information or any error contained in this manual.

No part of this manual may be reproduced or transmitted in any form or by any means, electronic or mechanical, including photocopying, recording, information storage and retrieval systems, for any purpose other than the purchaser's personal use, without the express written permission of Sonifex Ltd. Unless otherwise noted, all names of companies, products and persons contained herein are part of a completely fictitious adaptation and are designed solely to document the use of Sonifex product.

Made in the UK by **SONIFEX**

Contents

Product Warranty - 2 Year Extended

Sonifex Warranty & Liability Terms & Conditions

1. Definitions
2. Warranty

Unpacking Your Product

Repairs & Returns

CE Conformity

Safety & Installation of Mains Operated Equipment

Voltage Setting Checks

Fuse Rating

Power Cable & Connection

WEEE Directive

Atmosphere

1 CM-CU1 Commentator Unit

Introduction

CM-CU1 Main Panel Controls & Indicators

- ON AIR Button
- TALKBACK Buttons
- Headphone Monitor Controls
- PPM Meter Display
- Limit LED
- Power LED

CM-CU1 Front Panel Controls & Connections

- Phantom Power Select Switch
- Microphone Input Gain Controls
- Headphone Output
- Microphone Input
- Line Input

CM-CU1 Rear Panel Controls & Connections

- On Air Lock Controls
- Talkback Controls
- Limiter Controls
- Test Tone Switch
- Return Audio Inputs
- Audio Outputs
- DC Supply Input
- GPIO Port
- Mains Power

i

i

i

i

ii

iii

iii

iii

iii

iii

iii

iv

iv

1

1

3

3

4

4

4

4

4

5

5

5

5

5

5

6

6

6

6

7

7

7

7

8

8

CM-CU1 Configuration Options

- Entering Setup Mode
- Changing The Current Page
- Changing The Option Mode Setting
- Config Page 1 - ON AIR Button Enable/Disable & TALKBACK Button
- Latching Modes
- Config Page 2 - Line Input Routing to Output
- Config Page 3 - Commentator Mic & Line Input Routing to Headphones
- Config Page 4 - No Function
- Config Page 5 - Limit LED Colour & Limit/Power LED Brightness
- Config Page 6 - ON AIR/TALKBACK Button & PPM Brightness
- Config Page 7 - Save/Load Configurations & Firmware Version

9

9

9

9

9

9

10

10

10

10

10

10

11

CM-CU1 Technical Specification

2 CM-CU21 Commentator Unit

Introduction

CM-CU21 Main Panel Controls & Indicators

- On Air Buttons
- Talkback Buttons
- Headphone Monitor Controls
- Commentator 3 Line Input Level Control
- PPM Meter Display
- Limit LED
- Power LED

CM-CU21 Front Panel Controls & Connections

- Phantom Power Select Switches
- Microphone Input Gain Controls
- Headphone Outputs
- Microphone/Line Inputs

CM-CU21 Rear Panel Controls & Connections

- On Air Lock Controls
- Limiter Controls
- Test Tone Switch
- Talkback Controls
- Return Audio Inputs
- Audio Outputs
- DC Supply Input
- GPIO Port
- Mains Power

12

15

15

17

17

18

18

18

18

19

19

19

19

19

20

20

20

20

21

21

21

21

22

22

CM-CU21 Configuration Options	23
Entering Setup Mode	23
Changing The Current Page	23
Changing The Option Mode Setting	23
Config Page 1 - ON AIR Button Enable/Disable & TALKBACK Button	23
Latching Modes	23
Config Page 2 - Line Input Routing to Output	24
Config Page 3 - Commentator Mic & Line Input Routing to	
Headphones	24
Config Page 4 – Miscellaneous	25
Config Page 5 - Limit LED Colour & Limit/Power LED Brightness	25
Config Page 6 - ON AIR/TALKBACK Button & PPM Brightness	26
Config Page 7 - Save/Load Configurations & Firmware Version	26
CM-CU21 Technical Specification	28
Accessories	31
Transport Case	31
Accessories continued...	32
Commentator Front Cover Plate	32

Figures

Fig 1-1: CM-CU1 Commentator Unit	1
Fig 1-2: CM-CU1 Commentator Unit Block Diagram	2
Fig 1-3: Top Panel View Of CM-CU1	3
Fig 1-4: Front Panel View Of CM-CU1	5
Fig 1-5: Rear Panel View Of CM-CU1	6
Fig 2-1: CM-CU21 Commentator Unit	15
Fig 2-2: CM-CU21 Commentator Unit Block Diagram	16
Fig 2-3: Top Panel View Of CM-CU21	17
Fig 2-4: Front Panel View Of CM-CU21	19
Fig 2-5: Rear Panel View Of CM-CU21	20
Fig 3-1a: CM-CU21TP Commentator Unit Transport Case (empty)	31
Fig 3-1b: CM-CU21TP Commentator Unit Transport Case (filled)	31
Fig 3-2: CM-CU21CP Commentator Unit Front Cover Plate	32

SONIFEX

Register Online for an Extended 2 Year Warranty

As standard, Sonifex products are supplied with a 1 year back to base warranty.

If you register the product online, you can increase your product warranty to 2 years and we can also keep you informed of any product design improvements or modifications.

Product: _____

Serial No: _____

To register your product, please go online to www.sonifex.co.uk/register

Product Warranty - 2 Year Extended

As standard, Sonifex products are supplied with a 1 year back to base warranty. In order to register the date of purchase and so that we can keep you informed of any product design improvements or modifications, it is important to complete the warranty registration online. Additionally, if you register the product on the Sonifex website, you can increase your product warranty to 2 years. Go to the Sonifex website at: <http://www.sonifex.co.uk/technical/register/index.asp> to apply for your 2 year warranty.

Note: For your own records the product serial number is recorded on the CE certification page of this handbook.

Sonifex Warranty & Liability Terms & Conditions

1. Definitions

‘the Company’ means Sonifex Ltd and where relevant includes companies within the same group of companies as Sonifex Limited.

‘the Goods’ means the goods or any part thereof supplied by the Company and where relevant includes: work carried out by the Company on items supplied by the Purchaser; services supplied by the Company; and software supplied by the Company.

‘the Purchaser’ means the person or organisation who buys or has agreed to buy the Goods.

‘the Price’ means the Price of the Goods and any other charges incurred by the Company in the supply of the Goods.

‘the Warranty Term’ is the length of the product warranty which is usually 12 months from the date of despatch; except when the product has been registered at the Sonifex website when the Warranty Term is 24 months from the date of despatch.

‘the Contract’ means the quotation, these Conditions of Sale and any other document incorporated in a contract between the Company and the Purchaser.

This is the entire Contract between the parties relating to the subject matter hereof and may not be changed or terminated except in writing in accordance with the provisions of this Contract. A reference to the consent, acknowledgement, authority or agreement of the Company means in writing and only by a director of the Company.

2. Warranty

- a. The Company agrees to repair or (at its discretion) replace Goods which are found to be defective (fair wear and tear excepted) and which are returned to the Company within the Warranty Term provided that each of the following are satisfied:
 - i. notification of any defect is given to the Company immediately upon its becoming apparent to the Purchaser;
 - ii. the Goods have only been operated under normal operating conditions and have only been subject to normal use (and in particular the Goods must have been correctly connected and must not have been subject to high voltage or to ionising radiation and must not have been used contrary to the Company’s technical recommendations);
 - iii. the Goods are returned to the Company’s premises at the Purchaser’s expense;
 - iv. any Goods or parts of Goods replaced shall become the property of the Company;
 - v. no work whatsoever (other than normal and proper maintenance) has been carried out to the Goods or any part of the Goods without the Company’s prior written consent;

- vi. the defect has not arisen from a design made, furnished or specified by the Purchaser;
 - vii. the Goods have been assembled or incorporated into other goods only in accordance with any instructions issued by the Company;
 - viii. the defect has not arisen from a design modified by the Purchaser;
 - ix. the defect has not arisen from an item manufactured by a person other than the Company. In respect of any item manufactured by a person other than the Company, the Purchaser shall only be entitled to the benefit of any warranty or guarantee provided by such manufacturer to the Company.
- b. In respect of computer software supplied by the Company the Company does not warrant that the use of the software will be uninterrupted or error free.
- c. The Company accepts liability:
- (i) for death or personal injury to the extent that it results from the negligence of the Company, its employees (whilst in the course of their employment) or its agents (in the course of the agency);
 - (ii) for any breach by the Company of any statutory undertaking as to title, quiet possession and freedom from encumbrance.
- d. Subject to conditions (a) and (c) from the time of despatch of the Goods from the Company's premises the Purchaser shall be responsible for any defect in the Goods or loss, damage, nuisance or interference whatsoever consequential economic or otherwise or wastage of material resulting from or caused by or to the Goods. In particular the Company shall not be liable for any loss of profits or other economic losses. The Company accordingly excludes all liability for the same.
- e. At the request and expense of the Purchaser the Company will test the Goods to ascertain performance levels and provide a report of the results of that test. The report will be accurate at the time of the test, to the best of the belief and knowledge of the Company, and the Company accepts no liability in respect of its accuracy beyond that set out in Condition (a).
- f. Subject to Condition (e) no representation, condition, warranty or other term, express or implied (by statute or otherwise) is given by the Company that the Goods are of any particular quality or standard or will enable the Purchaser to attain any particular performance or result, or will be suitable for any particular purpose or use under specific conditions or will provide any particular capacity, notwithstanding that the requirement for such performance, result or capacity or that such particular purpose or conditions may have been known (or ought to have been known) to the Company, its employees or agents.
- g. (i) To the extent that the Company is held legally liable to the Purchaser for any single breach of contract, tort, representation or other act or default, the Company's liability for the same shall not exceed the price of the Goods.
- (ii) The restriction of liability in Condition (g)(i) shall not apply to any liability accepted by the Seller in Condition (c).
- h. Where the Goods are sold under a consumer transaction (as defined by the Consumer Transactions (Restrictions on Statements) Order 1976) the statutory rights of the Purchaser are not affected by these Conditions of Sale.

Unpacking Your Product

Each product is shipped in protective packaging and should be inspected for damage before use. If there is any transit damage take pictures of the product packaging and notify the carrier immediately with all the relevant

details of the shipment. Packing materials should be kept for inspection and also for if the product needs to be returned.

The product is shipped with the following equipment so please check to ensure that you have all of the items below. If anything is missing, please contact the supplier of your equipment immediately.

Item	Quantity
Product unit	1
IEC mains lead fitted with moulded mains plug	1
Handbook and warranty card	1

If you require a different power lead, please let us know when ordering the product.

Repairs & Returns

Please contact Sonifex or your supplier if you have any problems with your Sonifex product. Email technical.support@sonifex.co.uk for the repair/upgrade/returns procedure, or for support & questions regarding the product operation.

CE Conformity

The products in this manual comply with the essential requirements of the relevant European health, safety and environmental protection legislation.

The technical justification file for this product is available at Sonifex Ltd.

The declaration of conformity can be found at:
<http://www.sonifex.co.uk/declarations>

Safety & Installation of Mains Operated Equipment

There are no user serviceable parts inside the equipment. If you should ever need to look inside the unit, always disconnect the mains supply before removing the equipment covers. The cover is connected to earth by means of the fixing screws. It is essential to maintain this earth/ground connection to ensure a safe operating environment and provide electromagnetic shielding.

Voltage Setting Checks

Ensure that the machine operating voltage is correct for your mains power supply by checking the box in which your product was supplied. The voltage is shown on the box label. The available voltage settings are 115V, or 230V. Please note that all products are either switchable between 115V and 230V, or have a universal power supply.

Fuse Rating





The product is supplied with a single fuse in the live conducting path of the mains power input. For reasons of safety it is important that the correct rating and type of fuse is used. Incorrectly rated fuses could present a possible fire hazard, under equipment fault conditions. The active fuse is fitted on the outside rear panel of the unit.

Power Cable & Connection

An IEC power connector is supplied with the product which has a moulded plug attached.

The mains plug or IEC power connector is used as the disconnect device. The mains plug and IEC power connector shall remain readily operable to disconnect the apparatus in case of a fault or emergency.

The mains lead is automatically configured for the country that the product is being sent to, from one of:

Territory	Voltage	IEC Lead Type	Image
UK & Middle East	230V	UK 3 pin to IEC lead	
Europe	230V	European Schuko round 2 pin to IEC lead	
USA, Canada and South America	115V	3 flat pin to IEC lead	
Australia & New Zealand	230V	Australasian 3 flat pin to IEC lead	

Connect the equipment in accordance with the connection details and before applying power to the unit, check that the machine has the correct operating voltage for your mains power supply.

This apparatus is of a class I construction. It must be connected to a mains socket outlet with a protective earthing connection.

Important note: If there is an earth/ground terminal on the rear panel of the product then it must be connected to Earth.

WEEE Directive



The Waste Electrical and Electronic Equipment (WEEE) Directive was agreed on 13 February 2003, along with the related Directive 2002/95/EC on Restrictions of the use of certain Hazardous Substances in electrical and electronic equipment (RoHS). The Waste Electrical and Electronic Equipment Directive (WEEE) aims to minimise the impacts of electrical and electronic equipment on the environment during their life times and when they become waste. All products manufactured by Sonifex Ltd have the WEEE directive label placed on the case. Sonifex Ltd will be happy to give you information about local organisations that can reprocess the product when it reaches its “end of use”, or alternatively all products that have reached “end of use” can be returned to Sonifex and will be reprocessed correctly free of charge.

Atmosphere/Environment

This apparatus should be installed in an area that is not subject to excessive temperature variation (<0°C, >50°C), moisture, dust or vibration.

This apparatus shall not be exposed to dripping or splashing, and no objects filled with water, such as vases shall be placed on the apparatus.

1 CM-CU1 Commentator Unit

Introduction



Fig 1-1: CM-CU1 Commentator Unit

The CM-CU1 Commentator Unit is a high quality, portable broadcast mixer and 4-wire talkback unit. Its sturdy construction and flexibility of features make it suitable for use in a wide variety of environments.

It provides a fully featured commentator position with both limited, transformer balanced, and non-limited, electronically balanced outputs. A limit indicator on the main panel shows when the adjustable limiter on the mix output is active, and a bright 21 segment LED PPM meter, which can be disabled, shows the main output level.

The line input can be configured to remain present at the mix output even if the commentator is off air, making it useful for routing crowd effects or pre-recorded material to the programme feed. Its presence in the commentator’s headphones is also configurable to suit the application.

Four talkback output channels, with a built in limiter, are available to the commentator. They have adjustable gain and can be linked to provide simultaneous operation.

A wide input gain range and switchable phantom power provides support for a variety of microphone types, from high output phantom units to low output ribbon microphones.

There are 5 transformer balanced return audio inputs which, along with the commentator input, are routed to the headphone monitor controls. With these headphone controls, any input can be level adjusted, and sent to either the left, right or both ears.

A GPIO port gives an open-collector driven output indication of any active on air or talkback channels, and four remote inputs provide an external call/alert to each of the talkback controls.

The Commentator Unit has a built in line-up tone generator for easy channel identification and cabling checks, and a flexible range of options allow the unit to be customised to better suit the operational and users’ personal requirements.

1 CM-CU1 System Diagram

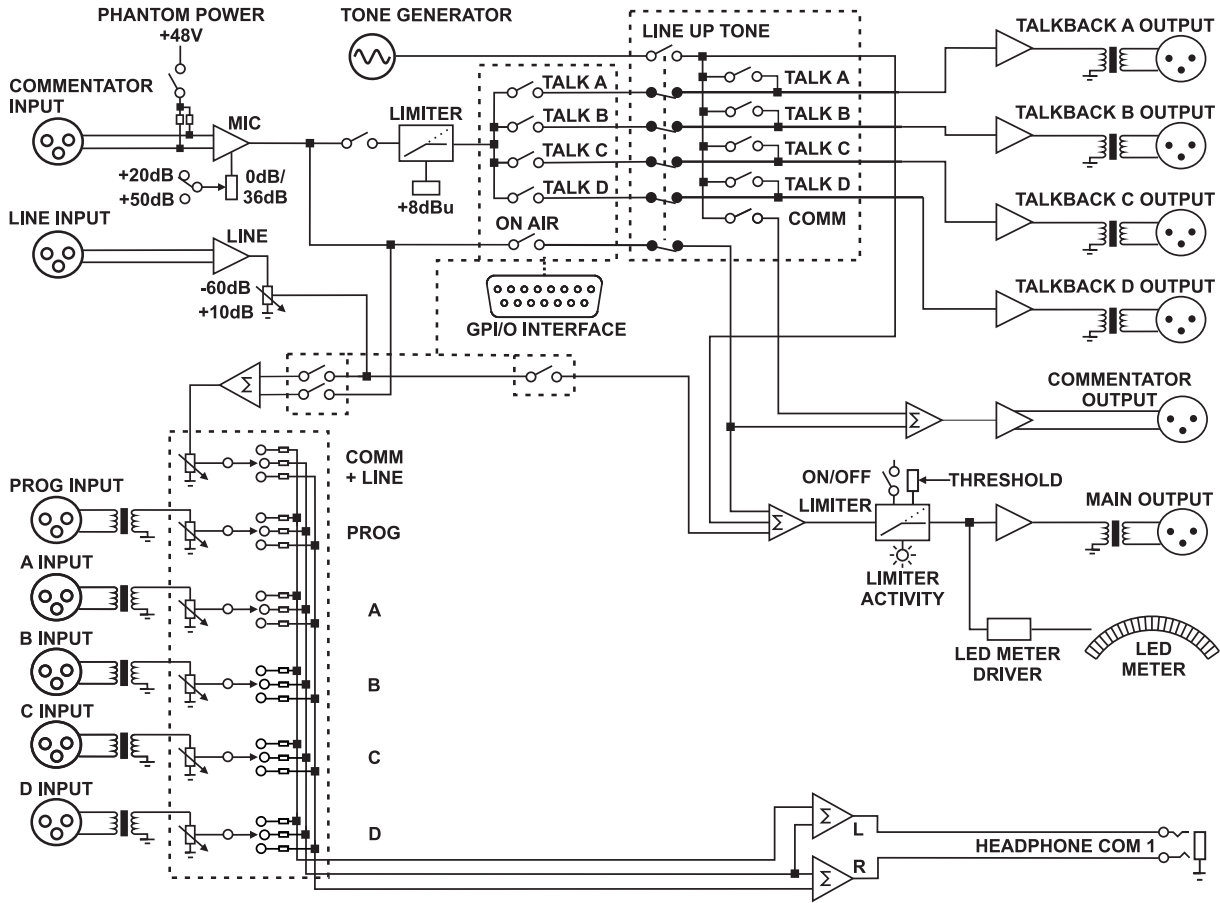

Fig 1-2: CM-CU1 Commentator Unit Block Diagram

CM-CU1 Main Panel Controls & Indicators



Fig 1-3: Top Panel View Of CM-CU1

The main panel of the Commentator Unit is split into two areas. At the top are the mix output PPM meter display, mix output limiter active indicator and the power indicator LED. Below this are the main commentator position controls, with the TALKBACK and ON AIR buttons located towards the bottom.

ON AIR Button

The ON AIR button routes the commentator microphone input signal to the Comm Output and to the Mix Output. This button has a latching action; press to activate and press again to deactivate. When the On Air control is active, the button illuminates red and the corresponding open collector driver output on the GPIO port is activated.

The line input signal is permanently routed to the mix output by default.

It is possible to configure the line input signal to be routed only when the ON AIR button is active. See Page 10 'Config Page 2 - Line Input Routing to Output' for details.

TALKBACK Buttons

The TALKBACK A, B, C and D buttons allow the commentator's microphone signal to be redirected to the corresponding Talkback Output. The commentator output is muted and the commentator's signal is removed from the Mix Output.

The five return audio inputs Prog, A, B, C and D function normally when a Talkback channel is active, allowing full-duplex communication between the commentator and a third party. These buttons have a momentary action by default; press to activate, release to deactivate. See Page 9 'Config Page 1 - ON AIR Button Enable/Disable & TALKBACK Button Latching Modes' for details of how to change the button action. When a Talkback control is active, the button illuminates green and the corresponding open collector driver output on the GPIO port is activated.

Headphone Monitor Controls

The commentator position has a set of six headphone controls which allows it to monitor all of the units' return audio and the commentator and line inputs, if active. Each available input has an associated level adjustment potentiometer and a headphone channel selector switch. Each potentiometer provides a level adjustment from "full off" to "full on", and the headphone channel selector determines which ear the associated signal is routed to; either the left, the right or to both ears when the switch is in the centre position. By default, the commentator input signal is only routed to the headphone monitor controls when the On Air control is active. It is possible to route this signal to the headphones permanently, regardless of

the state of the On Air control line input. See Page 10 'Config Page 3 - Commentator Mic & Line Input Routing to Headphones' for details.

It is also possible to configure the presence of the line input signal in the headphones using Config Page 3 too. By default, the line input signal is permanently routed to the headphone monitor controls.

PPM Meter Display

The 21 segment LED PPM meter display indicates the level of the signal on the Mix Output. The PPM scale conforms to IEC60268-10 11a and a dB scale is also shown. There are options to set the brightness level of the PPM meter, or it can be disabled if it is not required. See Page 10 'Config Page 5 - Limit LED Colour & Limit/Power LED Brightness' for details.

Limit LED

The limit LED illuminates when the adjustable limiter on the Mix Output is enabled and active. See Page 6 for information on the Limiter controls. The colour and brightness level of the limit LED can be changed if required. See Page 10 'Config Page 5 - Limit LED Colour & Limit/Power LED Brightness' for details.

Power LED

The power LED illuminates red to indicate that the unit has power from either of its mains or DC inputs. If this indicator is not on when mains power is connected to the unit, this may indicate a ruptured mains fuse or a problem with the internal power supply module. The power LED also indicates when the unit is in setup mode by flashing amber/red.

CM-CU1 Front Panel Controls & Connections

The front panel of the Commentator Unit has the commentator input and headphone output as well as the microphone power and gain controls.

Phantom Power Select Switch

The commentator input supports phantom powered microphones. The commentator position has a dedicated phantom power switch that enables the 48V supply.

Microphone Input Gain Controls

The commentator microphone input has an adjustable gain setting. The total gain range of +20dB to +86dB is split into two, to provide greater accuracy of adjustment. The mic gain switch sets the base gain value of either +20dB or +50dB for the input. The mic gain potentiometer can then be adjusted to add up to 36dB of additional gain.

Headphone Output

The front panel mounted headphone output is via a ¼" stereo jack socket, which is locking to prevent the headphone plug from being accidentally pulled out.

Microphone Input

The microphone input is via a 3 pin female XLR-3 connector with the following connections:

- Pin 1: Ground
- Pin 2: Phase
- Pin 3: Non-phase

Line Input

The line input is via a 3 pin female XLR-3 connector with the following connections:

- Pin 1: Ground
- Pin 2: Phase
- Pin 3: Non-phase



Fig 1-4: Front Panel View Of CM-CU1

CM-CU1 Rear Panel Controls & Connections

The rear panel of the Commentator Unit carries the five return audio inputs and commentator, talkback and mix output connectors. Four additional controls are located on the rear panel; On Air Lock, Talkback Gang, Limiter and Test Tone.

On Air Lock Controls

The On Air Lock prevents the commentator's ON AIR button from being deactivated accidentally. When the On Air Lock is enabled, the on air channel can only be deactivated by first pressing the pushbutton located next to the On Air Lock switch. A slot in the rear panel makes locating the On Air Lock pushbutton easy; simply position your finger in the slot in the rear panel, indicated by the "ON AIR LOCK" text on the top panel, then slide your finger down the slot until you reach the pushbutton.

Talkback Controls

The TALKBACK GANG switch links the operation of each of the commentator's TALKBACK A, B, C and D buttons. When this switch is on, pressing one of the TALKBACK buttons automatically activates the other TALKBACK buttons. Up to an additional 12dB of gain is available on all talkback outputs, if required. This is applied prior to the limiter and is adjusted using the rear panel GAIN potentiometer.

Limiter Controls

The LIMITER ON/OFF switch and LEVEL potentiometer control the limiter that is applied to the Mix Output. The potentiometer sets the threshold level at which the limiter becomes active, and has a range of between -13dB to the maximum output level of +25dB.



Fig 1-5: Rear Panel View Of CM-CU1

Test Tone Switch

The CM-CU1 has a built in test tone generator which selectively routes a line-up tone to all outputs to assist channel identification and cabling checks. There are two test tone modes; manual and auto. Regardless of mode, a 1kHz tone is permanently routed to the Mix Output and the PPM meter will indicate that the signal level is 0dBu. The test tone is enabled by sliding the TEST TONE switch to the upper "ON" position. To change the test tone mode; keep the Talkback B and Talkback C buttons pressed for 2.5 seconds.

Test Tone Manual Mode

With the test tone in manual mode, the ON AIR and TALKBACK buttons flash amber. The test tone can be routed to the Comm and Talkback Outputs by pressing the ON AIR or corresponding TALKBACK buttons. The ON AIR button illuminates red when pressed and the TALKBACK buttons illuminate green. When the button is released, the tone on that output is muted.

Test Tone Auto Mode

With the test tone in auto mode, each of the Comm and Talkback outputs are automatically identified by a unique number of short tone bursts, lasting 0.25 seconds each, which are repeated every 3 seconds. Each button flashes when tone is being routed to the corresponding output. The number of pulses on each output is shown below:

Comm	1 pulse
Talkback A	2 pulses
Talkback B	3 pulses
Talkback C	4 pulses
Talkback D	5 pulses

The 5 return audio inputs function normally when the test tone is enabled. This could be useful in allowing the user to receive instructions on which channel to output tone to when using the test tone in manual mode. When the test tone is disabled, normal operating mode is resumed and the On Air

and Talkback buttons return to the state they were in prior to entering test tone mode.

Return Audio Inputs

The five transformer balanced return audio inputs, Prog, A, B, C and D are via 3 pin female XLR-3 connectors with the following connections:

- Pin 1: Ground
- Pin 2: Phase
- Pin 3: Non-phase

Audio Outputs

The electronically balanced commentator output, and the transformer balanced talkback A, B, C and D and mix outputs are all via 3 pin male XLR-3 connectors with the following connections:

- Pin 1: Ground
- Pin 2: Phase
- Pin 3: Non-phase

DC Supply Input

The commentator unit can be powered from an external, regulated 12V or 24V DC power source. The DC input is via a 4 pin male XLR-4 connector with the following connections:

- Pin 1: 0V
- Pin 2: No connection
- Pin 3: No connection
- Pin 4: +VE (12-24 Volt DC)

When powering the CM-CU1 via the DC supply input, it is important to ensure that the unit is suitably earthed. An earth connection point is provided on the rear panel in the form of a M4 stud and screw and this should be connected directly to a technical earth.

GPIO Port

The CM-CU1's GPIO port has 5 open-collector driven outputs and 4 active low inputs. The open-collector outputs, which are low (conducting) when active, indicate which of the On Air or Talkback channels are active.

Each of the 4 active low inputs drives a call/alert signal on the corresponding Talkback button. When an input is active, the associated TALKBACK button flash amber.

The GPIO port connector is a 15-way female D-type with the following pin assignments:

Pin Number	I/O	Function
1	O	Commentator ON AIR active – open collector output
2	O	TALKBACK A active – open collector output
3	O	TALKBACK B active – open collector output
4	O	TALKBACK C active – open collector output
5	O	TALKBACK D active – open collector output
6	-	Digital ground (0V)
7	-	Digital ground (0V)
8	-	No connection
9	-	Digital ground (0V)
10	I	TALKBACK A call/alert – active low input
11	I	TALKBACK B call/alert – active low input
12	-	Digital ground (0V)
13	I	TALKBACK C call/alert – active low input
14	I	TALKBACK D call/alert – active low input
15	-	Digital ground (0V)

Mains Power

Mains power is applied via a standard three-pin IEC male socket. Mains voltages between 85V and 264V AC at frequencies between 47 and 63Hz are accepted without adjustment.

A 1A, 5 x 20mm SB fuse is used. The Earth pin MUST be connected to ensure safety.

CM-CU1 Configuration Options

The CM-CU1 has several user configurable options that can be changed to suit specific operational or personal requirements. These options can only be changed by entering a setup mode, which is accessible when the unit is powered-up.

Entering Setup Mode

Apply power to the unit whilst keeping the TALKBACK A and TALKBACK B buttons pressed for 5 seconds. The power indicator LED will flash red and amber to indicate that Setup Mode has been entered. The TALKBACK A and TALKBACK B buttons can now be released.

The configuration options are arranged in 7 pages, with up to 5 options in each page. The current page number is indicated on the PPM display by a single illuminated segment, e.g. segment 5 illuminated means that you are on Page 5.

Each option within the selected page is associated with one of the 5 main control buttons on the top panel of the unit. Each button flashes in a recurring sequence to indicate the current mode setting of the associated option. One flash equals mode 1, two flashes equals mode 2 etc. Buttons that do not have an associated option in the current page do not flash.

Please Note: when Page 6 is selected, all the segments in the PPM display are enabled to indicate the current PPM illumination level setting.

Changing The Current Page

Press and hold the ON AIR button for at least 1 second. The PPM display will change to indicate the new page.

Changing The Option Mode Setting

Press the appropriate button once. The number of flashes increases to indicate the new mode setting. Once the maximum option mode setting has been reached, the value wraps around to mode 1.

The configuration option settings for each page are listed below. The factory default settings for each option are shown in brackets:

Config Page 1 - ON AIR Button Enable/Disable & TALKBACK Button Latching Modes

ON AIR button:

- Mode 1 ON AIR is permanently disabled and cannot be selected.
- Mode 2 ON AIR can be selected as normal (default).
- Mode 3 ON AIR is permanently selected and cannot be disabled.

TALKBACK A button:

- Mode 1 TALKBACK A button momentary mode enabled (default).
- Mode 2 TALKBACK A button latching mode enabled.
- Mode 3 TALKBACK A button momentary and latching modes enabled.

TALKBACK B button:

- Mode 1 TALKBACK B button momentary mode enabled (default).
- Mode 2 TALKBACK B button latching mode enabled.
- Mode 3 TALKBACK B button momentary and latching modes enabled.

TALKBACK C button:

- Mode 1 TALKBACK C button momentary mode enabled (default).
- Mode 2 TALKBACK C button latching mode enabled.
- Mode 3 TALKBACK C button momentary and latching modes enabled.

TALKBACK D button:

- Mode 1 TALKBACK D button momentary mode enabled (default).
- Mode 2 TALKBACK D button latching mode enabled.
- Mode 3 TALKBACK D button momentary and latching modes enabled.

Please Note:

Momentary mode button operation – press to activate, release to deactivate. Latching mode button operation – press once to activate, press again to deactivate. Momentary and latching mode button operation - for momentary press the button for less than 0.25 sec, for latching press for more than 0.25 sec.

Config Page 2 - Line Input Routing to Output

ON AIR button:

- Mode 1 Line input permanently routed to Mix Output (default).
- Mode 2 Line input is permanently unrouted to Mix Output.
- Mode 3 Line input routed to Mix Output only when ON AIR is active.

TALKBACK A, B, C & D buttons:

No associated option on this page.

Config Page 3 - Commentator Mic & Line Input Routing to Headphones

ON AIR button:

- Mode 1 Commentator input permanently routed to Commentator headphones.
- Mode 2 Commentator input routed to Commentator headphones only when ON AIR is active (default).

TALKBACK A button:

- Mode 1 Line input routed to Commentator headphones only when ON AIR is active (provided line input is not permanently unrouted to mix output).
- Mode 2 Line input permanently routed to Commentator headphones (default).

TALKBACK B, C & D buttons:

No associated option on this page.

Config Page 4 - No Function

ON AIR button & TALKBACK A, B, C & D buttons:

No associated option on this page.

Config Page 5 - Limit LED Colour & Limit/Power LED Brightness

ON AIR button:

- Mode 1 Limit indicator illuminates blue when active (default).
- Mode 2 Limit indicator illuminates green when active.
- Mode 3 Limit indicator illuminates red when active.
- Mode 4 Limit indicator illuminates white when active. This setting can be used when a brighter limit indication is required.

TALKBACK A button:

- Mode 1 Power and limit indicator brightness level 1 (minimum brightness).
- Mode 2 Power and limit indicator brightness level 2.
- Mode 3 Power and limit indicator brightness level 3 (default).
- Mode 4 Power and limit indicator brightness level 4.
- Mode 5 Power and limit indicator brightness level 5.
- Mode 6 Power and limit indicator brightness level 6.
- Mode 7 Power and limit indicator brightness level 7.
- Mode 8 Power and limit indicator brightness level 8 (maximum brightness).

TALKBACK B, C & D buttons:

No associated option on this page.

Config Page 6 - ON AIR/TALKBACK Button & PPM Brightness

ON AIR button:

- Mode 1 ON AIR and TALKBACK button brightness level 1 (minimum brightness).
- Mode 2 ON AIR and TALKBACK button brightness level 2.
- Mode 3 ON AIR and TALKBACK button brightness level 3.
- Mode 4 ON AIR and TALKBACK button brightness level 4.
- Mode 5 ON AIR and TALKBACK button brightness level 5.
- Mode 6 ON AIR and TALKBACK button brightness level 6.
- Mode 7 ON AIR and TALKBACK button brightness level 7 (maximum brightness) (default).

TALKBACK A button:

Mode 1	PPM display brightness level 1 (minimum brightness).
Mode 2	PPM display brightness level 2.
Mode 3	PPM display brightness level 3.
Mode 4	PPM display brightness level 4.
Mode 5	PPM display brightness level 5 (default).
Mode 6	PPM display brightness level 6.
Mode 7	PPM display brightness level 7 (maximum brightness).
Mode 8	PPM display disabled.

TALKBACK B button:

No associated option on this page. This button illuminates red to indicate button brightness level.

TALKBACK C button:

No associated option on this page. This button illuminates amber to indicate button brightness level.

TALKBACK D button:

No associated option on this page. This button illuminates green to indicate button brightness level.

Config Page 7 - Save/Load Configurations & Firmware Version

The last page allows you to save the current option settings to either of two available backup sets that are unaffected by subsequent changes to the option settings. The backup sets can then be reloaded when required. The load/save functions only work whilst in Config Page 7.

Version Firmware

Config Page 7 shows the current firmware version by flashing the Limit LED in a recurring sequence i.e. 1 flash for version 1, 2 flashes for version 2, etc.

To Save The Current Option Settings to Backup Set 1

Press and hold the ON AIR and TALKBACK B buttons for 2 seconds. These buttons will then illuminate red to verify that the options have been saved to backup set 1.

To Save The Current Option Settings to Backup Set 2

Press and hold the ON AIR and TALKBACK D buttons for 2 seconds. These buttons will then illuminate red to verify that the options have been saved to backup set 2.

To Load Backup Set 1 & Overwrite The Current Option Settings

Press and hold the ON AIR and TALKBACK A buttons for 2 seconds. These buttons will then illuminate red to verify that backup set 1 has been loaded.

To Load Backup Set 2 & Overwrite The Current Option Settings

Press and hold the ON AIR and TALKBACK C buttons for 2 seconds. These buttons will then illuminate red to verify that backup set 2 has been loaded.

To Exit Setup Mode

Press and hold the TALKBACK A and TALKBACK B buttons for 3 seconds. When the power indicator stops flashing, the On Air buttons can be released and the unit enters normal operating mode.

In addition to being able to load and save options, it is also possible to return the setup options to their factory default settings. Please note: all changes made to the options settings will be lost. Loading of the factory defaults does not affect the options stored in the backup sets.

To Return The Current Option Settings to Factory Defaults

Apply power to the unit whilst keeping TALKBACK C and TALKBACK D buttons pressed for 5 seconds. These buttons then illuminate red to verify that the default options have been loaded. After the default options have been restored, the unit returns to normal operating mode.

CM-CU1 Technical Specification

Microphone Input

Gain Range: +20dB to +86dB

Maximum Input Level: -6dBu

Equivalent Input Noise: 130dB Ref. 80dB gain with 150Ω termination

Equivalent Input Noise: 128dB Ref. 50dB gain with 150Ω termination

C.M.R.R. >60dB

Frequency Response: ±0.5dB 20Hz to 22kHz
Ref 50dB gain @ 1kHz

Electronically Balanced Line Input

Gain Range: -83dB to +10dB

Maximum Input Level: +25dBu

C.M.R.R. >70dB

Frequency Response: ±0.2dB 20Hz to 22kHz
Ref 0dBu @ 1kHz

Transformer Balanced Monitor Inputs

Gain Range: -66dB to +11dB measured @ Headphone
output

Maximum Input Level: +21dBu

C.M.R.R. >55dB

Frequency Response: ±0.5dB 20Hz to 22kHz
Ref 0dBu @ 1kHz

Transformer Balanced Mix Output

Maximum Output Level +24dBu
(Limiter Off):

Frequency Response: ±0.5dB 20Hz to 22kHz
Ref 0dBu @ 1kHz

Noise: -94dB Average weighting
Ref +8dBu

THD & N: <0.02% Ref. 1kHz @ +8dBu

THD & N: <0.065% Ref. 1kHz @ +18dBu

1% Distortion Point: +18dBu @ 24Hz

Transformer Balanced Talkback Outputs

Maximum Output Level +8dBu
Limited:

Frequency Response: ±0.5dB 20Hz to 22kHz
Ref 0dBu @ 1kHz

Noise: -94dB Average weighting
Ref +8dBu

THD & N: <0.02% Ref. 1kHz @ +8dBu

Gain Adjustment: 0dB to +12dB

Electronically Balanced Comm Output

Maximum Output Level: +25dBu

Frequency Response: ±0.2dB 20Hz to 22kHz
Ref 0dBu @ 1kHz

Noise: -98dB Average weighting
Ref+8dBu

THD & N: <0.002% Ref. 1kHz @ +8dBu

Headphone Output

Gain Range: -66dB to +11dB

Maximum Output Level:	+19dBu
Frequency Response:	±0.5dB 20Hz to 22kHz Ref 0dBu @ 1kHz
Noise:	-85dB Average weighting Ref +8dBu
THD & N:	<0.005% Ref. 1kHz @ +8dBu

Main Panel Operational Controls & Indicators

On-Air Button:	Illuminated button with latching action
Talkback A, B, C & D Buttons:	Illuminated buttons with selectable momentary and/or latching action
Headphone Monitor Controls:	Input source level adjustment potentiometers Headphone channel selection switches
Line Input Level:	Line input mode level potentiometer
PPM Meter:	21 segment display showing mix output level, brightness level is selectable
Limit LED:	Indicates main output limiter is active, colour & brightness level is selectable
Power LED:	Indicates operating mode; normal or setup

Front Panel Operational Controls

Phantom:	Switch to enable 48V microphone phantom power
Mic Gain:	Microphone gain potentiometer and range select switch selects +20dB to +56dB or +50 to +86dB

Rear Panel Operational Controls

On Air Lock:	Switch to prevent On Air control from being deactivated Momentary push-button to override on air lock
T/B Gang:	Switch to link operation of talkbacks A, B, C & D
T/B Gain:	0dB to +12dB
Limiter:	Switch to enable limiter on mix output Limit level adjustment potentiometer
Test Tone:	Switch to enable 1 kHz line-up tone

Configuration Options – Accessible via Setup Mode

On Air Control Mode:	Disabled, normal or permanently on
Talkback Button Action:	Momentary, latching or both
Headphone Routing:	Line-level input permanently routed/routed if on air to Commentator headphones Commentator input permanently routed/not routed to headphone monitors
Line Level Input Routing:	Line-level input permanently routed/not routed/routed if on air to main output
Display Preferences:	Limit LED colour and brightness Button LED brightness PPM meter LED brightness/disable
Permanent Option Backup:	Save/load options to/from Permanent backup or return to factory defaults

Front Panel Connections

Headphone Output:	1 x locking headphone jack socket
Microphone Input:	1 x XLR-3 pin latching female
Line Input:	1 x XLR-3 pin latching female

Rear Panel Connections

Prog, A, B, C & D Inputs: 5 x XLR-3 pin female (transformer balanced)

Comm Output: 1 x XLR-3 pin male (electronic balanced)

Talkback A, B, C & D Outputs: 4 x XLR-3 pin male (transformer balanced)

Mix Output: 1 x XLR-3 pin male (transformer balanced)

GPIO Port: 15-way 'D'-type socket

Mains Input: Universal filtered IEC, continuously rated 85-264VAC, 47-63Hz, 10W

Fuse Rating: Anti-surge fuse 1A 20 x 5mm

DC Input: XLR-4 pin male 12V DC, 650mA Typical, 850mA Maximum
24V DC, 325mA Typical, 425mA Maximum

Earth Point: M4 stud.

Equipment Type

CM-CU1 Commentator Unit, 1 Presenter

Physical Specification

Dimensions (Raw): 270mm (W) x 230mm (D) x 70mm (H - front) x 95mm (H - rear)
10.6" (W) x 9" (D) x 2.8" (H - front) x 3.7" (H - rear)

Dimensions (Boxed): 380mm (W) x 350mm (D) x 200mm (H)
15" (W) x 13.8" (D) x 7.8" (H)

Weight: Nett: 3.3kg Gross: 4.3kg
Nett: 7.3lbs Gross: 9.4lbs

Accessories

CM-CU21TP Commentator Unit Transport Case

Dimensions (Raw): 530mm (W) x 210mm (D) x 415mm (H)
20.9" (W) x 8.3" (D) x 16.3" (H)

Dimensions (Boxed): 600mm (W) x 260 (D) x 420 (H)
23.6" (W) x 10.2" (D) x 16.5" (H)

Weight: Net: 4.0kg Gross: 5.0kg
Net: 8.8lbs Gross: 11.0lbs

2 CM-CU21 Commentator Unit

Introduction



Fig 2-1: CM-CU21 Commentator Unit

The CM-CU21 Commentator Unit is a high quality, portable broadcast mixer and 4-wire talkback unit. Its sturdy construction and flexibility of features make it suitable for use in a wide variety of environments.

It provides two fully featured commentator positions and a third guest position that can alternatively be used as a line-level input, allowing program idents/effects to be mixed with the commentator inputs. Each position has an individual output, with two additional outputs providing a mix of all active commentary channels. A limit indicator on the main panel shows when the adjustable limiter on the mix outputs is active, and a bright 21 segment LED PPM meter, which can be disabled, shows the main output level.

Two talkback output channels, with a built in limiter, are available to each of the two main commentators. They have adjustable gain and can be linked to provide simultaneous operation.

A wide input gain range and switchable phantom power on each commentary position provides supports for a variety of microphone types, from high output phantom units to low output ribbon microphones.

There are 4 transformer balanced return audio inputs which, along with the commentator inputs, are routed to the headphone monitor controls. With these headphone controls, any input can be level adjusted, and sent to either the left, right or both ears.

A GPIO port gives an open-collector driven output indication of any active on-air or talkback channels, and four remote inputs can be configured to provide either an external call/alert to each of the talkback controls, or external control of the talkback function. See Configuration Options on page 23 for details of the available settings.

The Commentator Unit has a built in line-up tone generator for easy channel identification and cabling checks, and a flexible range of options allow the unit to be customised to better suit the operational and users' personal requirements.

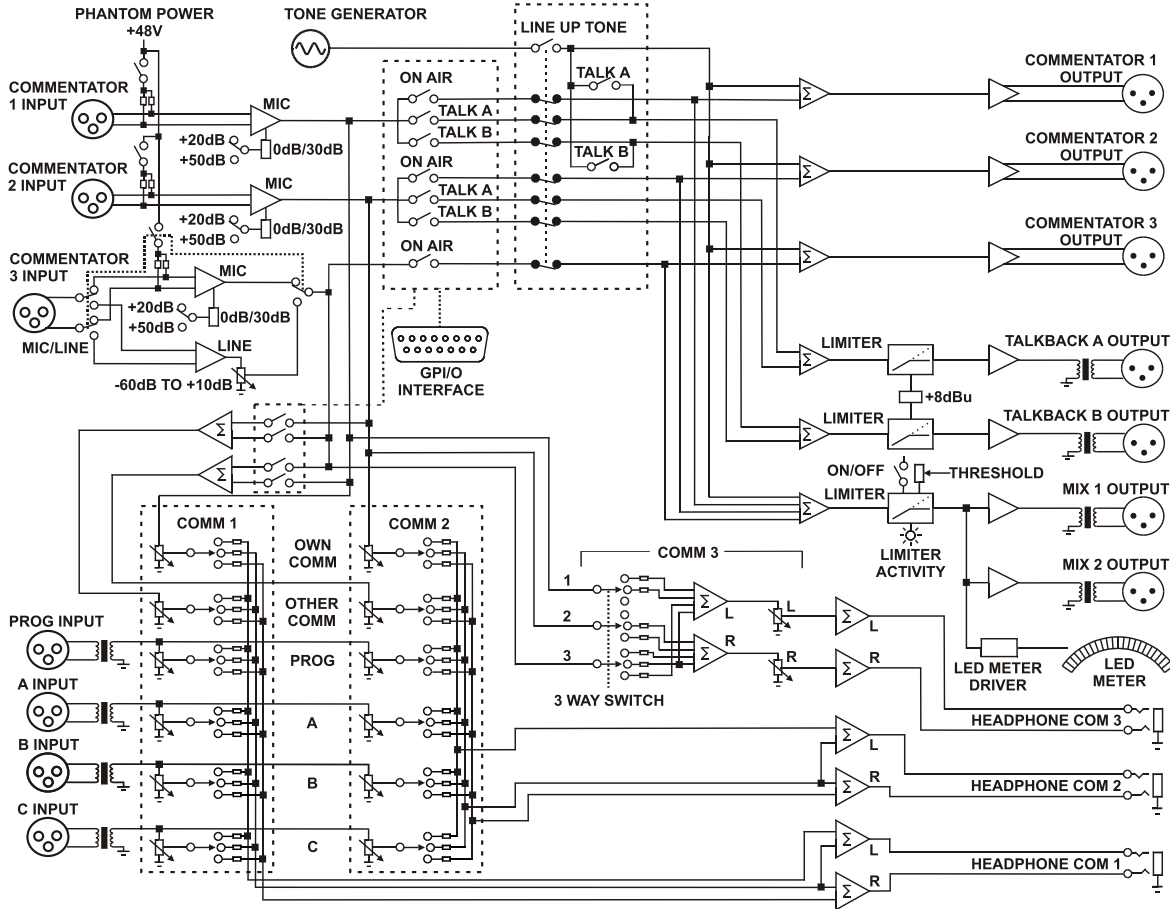

Fig 2-2: CM-CU21 Commentator Unit Block Diagram

CM-CU21 Main Panel Controls & Indicators

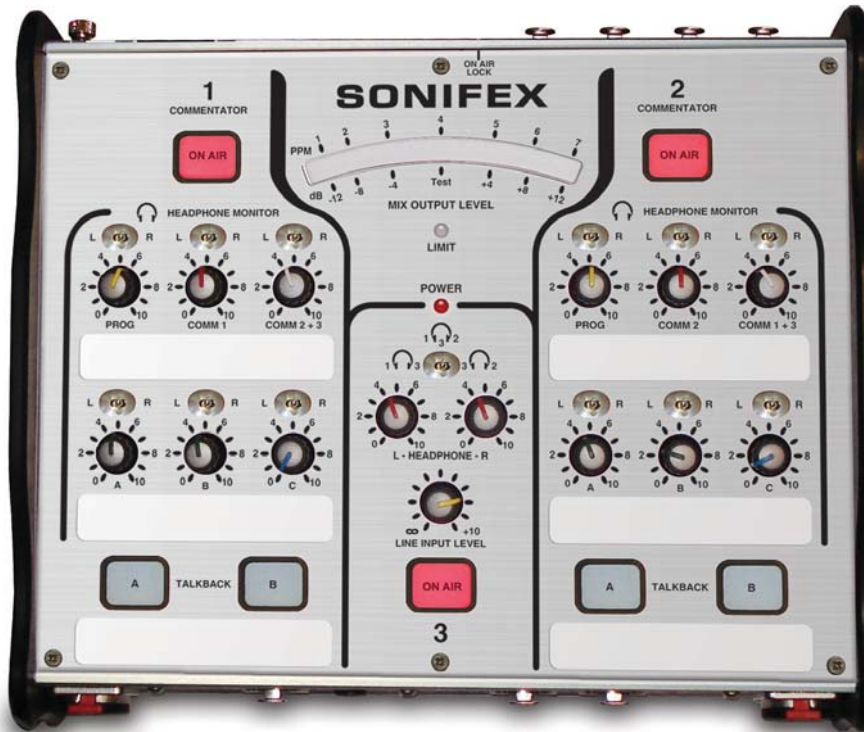

Fig 2-3: Top Panel View Of CM-CU21

The main or top panel of the Commentator Unit is split into four areas. To the left and right are the main commentator position controls, with the third commentator/guest position controls located in the centre, below the power indicator, mix output limiter active indicator and the PPM meter display.

On Air Buttons

The On Air buttons route the commentator microphone input signal to the corresponding Comm output and to both of the Mix Outputs, where it is mixed with all other active commentator signals. These buttons have a latching action; press to activate and press again to deactivate. When an On Air control is active, the button illuminates red and the corresponding open collector driver output on the GPIO port is activated.

A temporary mute function is available which can be used to interrupt the microphone signal on an active On Air channel. By pressing the active On Air button, any unwanted noises such as coughing, can be removed from the audio outputs. Please note: for this function to be available on a specific commentator position, the associated On Air button configuration mode must not be set to permanently disabled or selected, the temporary mute configuration option must be enabled and the On Air lock switch on the rear panel must be in the on position. See Configuration Options on Page 23 for details of how to change these settings.

Talkback Buttons

The Talkback A and B buttons allow either of the two main commentators' microphone signals to be redirected to the corresponding Talkback output. The associated Comm output is muted and the commentators' signal is removed from the Mix Outputs. The four return audio inputs Prog, A, B and C function normally when a Talkback channel is active, allowing full-duplex communication between the commentator and a third party.

An alternative operating mode allows the Talkback B buttons to act as a temporary mute control for the Comm1, Comm2 and Talkback A outputs. The Talkback B buttons are ganged and the status of any active On Air or Talkback A channels is restored once both of the Talkback B buttons are returned to the off state. The Talkback B output is not used in this mode. See Configuration Options on Page 23 for details of how to change these settings.

These buttons have a momentary action by default; press to activate, release to deactivate. See Configuration Options on page 25 for details of how to change the button action. When a Talkback control is active, the button illuminates green and the corresponding open collector driver output on the GPIO port is activated.

Headphone Monitor Controls

The two main commentator positions have six sets of headphones controls which allow them to monitor all of units' return audio and active commentator inputs. Each available input has an associated level adjustment potentiometer and a headphone channel selector switch. Each potentiometer provides a level adjustment from "full off" to "full on", and the headphone channel selector determines which ear the associated signal is routed to; either the left, the right or to both ears when the switch is in the centre position. By default, the commentator input signals are only routed to the headphone monitor controls when the corresponding On Air control is active. It is possible to route each of these signals to the

headphones permanently, regardless of the state of the corresponding On Air control. See Configuration Options on Page 24 for details.

The guest position, commentator 3, can be set to accept a line level input, and an additional option can be configured to prevent this signal from being routed to the commentator 1 and 2 headphone monitors.

The headphone controls for the third commentator position consist of left and right level adjustment potentiometers, and a switch to select the routing for the commentator input signals. With the switch in the left position, commentator 1 is heard in the left ear and commentator 3 is heard in the right ear. With the switch in the right position, commentator 2 is heard in the right ear and commentator 3 is heard in the left ear. When the switch is in the centre position, commentator 1 is heard in the left ear, commentator 2 is heard in the right ear and commentator 3's own signal is heard in both ears.

Commentator 3 Line Input Level Control

When the third commentator input is set to accept a line input, this potentiometer sets the gain applied to the signal prior to being routed to the headphone monitor and main output channels. The gain range is -83dB to +10dB with a maximum input level of +25dBu.

PPM Meter Display

The 21 segment LED PPM meter display indicates the level of the signal on the mix outputs. The PPM scale conforms to IEC60268-10 11a and a dB scale is also shown. There are options to set the brightness level of the PPM meter, or it can be disabled if it is not required. See Configuration Options on Page 26 for details.

Limit LED

The limit LED illuminates when the adjustable limiter on the mix outputs is enabled and active. See Rear Panel Controls on Page 20 for details of how to enable and adjust the limiter. The colour and brightness level of the limit LED can be changed if required, see Configuration Options on Page 25 for details.

Power LED

The power LED indicates that the unit has power from either of its mains or DC inputs when it illuminates red. If this indicator is not on when mains power is connected to the unit, this may indicate a ruptured mains fuse or a problem with the internal power supply module. The power LED also indicates when the unit is in setup mode by flashing amber/red.

The power LED brightness is adjusted using the same method as for the Limit LED.

CM-CU21 Front Panel Controls & Connections

The front panel of the Commentator Unit has all of the commentator inputs and headphone outputs as well as the microphone power and gain controls.

Phantom Power Select Switches

Each of the three commentator inputs support phantom powered microphones. The two main commentator positions have dedicated phantom power switches that enable the 48V supply. The third

commentator position has a three way switch that sets the input type. When the switch is in the bottom position, the input is a line level input. With the switch in the centre position, the input is for microphones not requiring phantom power. The top switch position enables the microphone input phantom power.

Microphone Input Gain Controls

Each of the commentator microphone inputs has an individually adjustable gain setting. The total gain range of +20dB to +86dB is split into two, to provide greater accuracy of adjustment. The mic gain switch sets the base gain value of either +20dB or +50dB for the corresponding input. The associated mic gain potentiometer can then be adjusted to add up to 36dB of additional gain.

Headphone Outputs

The front panel mounted headphone outputs are via ¼" stereo jack sockets. The two main commentator positions have locking sockets to prevent the headphone plug from being accidentally pulled out.



Fig 2-4: Front Panel View Of CM-CU21

Microphone/Line Inputs

The microphone inputs for the two main commentators and the microphone/line level input for the third position are via 3 pin female XLR-3 connectors with the following connections:

- Pin 1: Ground
- Pin 2: Phase
- Pin 3: Non-phase

CM-CU21 Rear Panel Controls & Connections

The rear panel of the Commentator Unit carries the four return audio inputs and all comm., talkback and mix output connectors. Four additional controls are located on the rear panel; On Air Lock, Limiter, Test Tone and Talkback Gang.

On Air Lock Controls

The On Air lock prevents any of the commentators On Air buttons from being deactivated accidentally. When the On Air lock is enabled, an On Air channel can only be deactivated by first pressing the pushbutton located next to the On Air lock switch. A slot in the rear panel makes locating the On Air lock pushbutton easy; simply position your finger in the slot in the rear panel, indicated by the "ON AIR LOCK" text on the top panel, then slide your finger down the slot until you reach the pushbutton.

Limiter Controls

The limiter enable switch and level potentiometer control the limiter that is applied to the main mix outputs. The potentiometer sets the threshold level at which the limiter becomes active, and has a range of between -13dB to the maximum output level of +25dB.

Test Tone Switch

The Commentator Unit has a built in Test Tone generator which selectively routes a line-up tone to all outputs to assist channel identification and cabling checks. There are two test tone modes; manual and auto. Regardless of mode, a 1 kHz tone is permanently routed to the mix outputs and the PPM meter will indicate that the signal level is 0dBu. The test tone is enabled by sliding the switch to the upper "ON" position. To change the test tone mode; keep the Commentator 1 and Commentator 2 On Air buttons pressed for 2.5 seconds.



Fig 2-5: Rear Panel View Of CM-CU21

Test Tone Manual Mode

With the test tone in manual mode, all On Air and Talkback buttons will flash amber. The test tone can be routed to the Comm and Talkback outputs by pressing the corresponding On Air or Talkback buttons. The On Air buttons will illuminate red when pressed and the Talkback buttons will illuminate green. When the button is released, the tone on that output will be muted.

Test Tone Auto Mode

With the test tone in auto mode, each of the Comm and Talkback outputs are automatically identified by a unique number of short tone bursts, lasting 0.25 seconds each, which are repeated every 3 seconds. Each button flashes when tone is being routed to the corresponding output. The number of pulses on each output is shown below:

Comm 1	1 pulse
Comm 2	2 pulses
Comm 3	3 pulses
Talkback A	4 pulses
Talkback B	5 pulses

The 4 return audio inputs function normally when the test tone is enabled. This could be useful in allowing the user to receive instructions on which channel to output tone to when using the test tone in manual mode. When the test tone is disabled, normal operating mode is resumed and the On Air and Talkback buttons will be returned to the state they were in prior to entering test tone mode.

Talkback Controls

The TALKBACK GANG switch links the operation of each of the commentator's TALKBACK A and B buttons. When this switch is on, pressing one of the TALKBACK buttons automatically activates the commentators' other TALKBACK button. Up to an additional 12dB of gain is available on

all talkback outputs, if required. This is applied prior to the limiter and is adjusted using the rear panel GAIN potentiometer.

Return Audio Inputs

The four transformer balanced return audio inputs, Prog, A, B and C are via 3 pin female XLR-3 connectors with the following connections:

- Pin 1: Ground
- Pin 2: Phase
- Pin 3: Non-phase

Audio Outputs

The three electronically balanced commentator outputs Comm1-3, and the transformer balanced talkback A and B and mix outputs are all via 3 pin male XLR-3 connectors with the following connections:

- Pin 1: Ground
- Pin 2: Phase
- Pin 3: Non-phase

DC Supply Input

The commentator unit can be powered from an external, regulated 12V or 24V DC power source. The DC input is via a 4 pin male XLR-4 connector with the following connections:

- Pin 1: 0V
- Pin 2: No connection
- Pin 3: No connection
- Pin 4: +VE (12-24 Volt DC)

When powering the Commentator Unit via the DC supply input, it is important to ensure the unit is suitably earthed. An earth connection point is provided on the rear panel in the form of a M4 stud and screw and this should be connected directly to a technical earth.

GPIO Port

The Commentator Unit’s GPIO port has 7 open-collector driven outputs and 4 active low inputs. The 7 open-collector outputs, which are low (conducting) when active, indicate which of the On Air or Talkback channels are active.

The 4 active low inputs can be configured to provide 2 different functions. In the default mode, these inputs drive a call/alert signal on the corresponding Talkback button. When an input is active, the associated Talkback button will flash amber. In the second mode, these inputs control the talkback function and the effect is similar to pressing the corresponding talkback button.

The GPIO port connector is a 15-way female D-type with the following pin assignments:

Pin Number	I/O	Function
1	O	Commentator 1 ON AIR active – open collector output
2	O	Commentator 1 TALKBACK A active – open collector output
3	O	Commentator 1 TALKBACK B active – open collector output
4	O	Commentator 2 ON AIR active – open collector output
5	O	Commentator 2 TALKBACK A active – open collector output
6	O	Commentator 2 TALKBACK B active – open collector output
7	O	Commentator 3 ON AIR active – open collector output
8	-	No connection
9	-	Digital ground (0V)
10	I	Commentator 1 TALKBACK A call/alert or activate – active low input
11	I	Commentator 1 TALKBACK B call/alert or activate – active low input
12	-	Digital ground (0V)
13	I	Commentator 2 TALKBACK A call/alert or activate – active low input
14	I	Commentator 2 TALKBACK B call/alert or activate – active low input
15	-	Digital ground (0V)

Mains Power

Mains power is applied via a standard three-pin IEC male socket. Mains voltages between 85V and 264V AC at frequencies between 47 and 63Hz are accepted without adjustment.

A 1A, 5 x 20mm SB fuse is used. The Earth pin MUST be connected to ensure safety.

CM-CU21 Configuration Options

The Commentator Unit has several user configurable options that can be changed to suit specific operational or personal requirements. These options can only be changed by entering a setup mode, which is accessible when the unit is powered-up.

Entering Setup Mode

Apply power to the unit whilst keeping the Commentator 1 and Commentator 2 On Air buttons pressed for 5 seconds. The power indicator LED will flash red and amber to indicate setup mode has been entered. The Commentator 1 and Commentator 2 On Air buttons can now be released.

The configuration options are arranged in 7 Pages, with up to 7 options in each Page. The current Page number is indicated on the PPM display by a single illuminated segment. Please note, when Page 6 is selected, all the segments in the PPM display are enabled to indicate the current PPM illumination level setting. Each option within the selected page is associated with one of the 7 main control buttons on the top panel of the unit. Each button flashes in a recurring sequence to indicate the current mode setting of the associated option. One flash equals mode 1, two flashes equals mode 2 etc. Buttons that do not have an associated option in the current page do not flash.

Please Note: when Page 6 is selected, all the segments in the PPM display are enabled to indicate the current PPM illumination level setting.

Changing The Current Page

Press and hold the Commentator 3 On Air button for at least 1 second. The PPM display will change to indicate the new page.

Changing The Option Mode Setting

Press the appropriate button once. The number of flashes will increase to indicate the new mode setting. Once the maximum option mode setting has been reached, the value will wrap around to mode 1.

The configuration option settings for each page are listed below. The factory default settings for each option are shown in brackets:

Config Page 1 - ON AIR Button Enable/Disable & TALKBACK Button Latching Modes

Commentator 1 ON AIR button:

- Mode 1 Commentator 1 ON AIR is permanently disabled and cannot be selected.
- Mode 2 Commentator 1 ON AIR can be selected as normal (default).
- Mode 3 Commentator 1 ON AIR is permanently selected and cannot be disabled.

Commentator 1 TALKBACK A button:

- Mode 1 Commentator 1 TALKBACK A button momentary mode enabled (default).
- Mode 2 Commentator 1 TALKBACK A button latching mode enabled.
- Mode 3 Commentator 1 TALKBACK A button momentary and latching modes enabled.

Commentator 1 TALKBACK B button:

- Mode 1 Commentator 1 TALKBACK B button momentary mode enabled (default).
- Mode 2 Commentator 1 TALKBACK B button latching mode enabled.
- Mode 3 Commentator 1 TALKBACK B button momentary and latching modes enabled.

Commentator 2 ON AIR button:

- Mode 1 Commentator 2 ON AIR is permanently disabled and cannot be selected.
- Mode 2 Commentator 2 ON AIR can be selected as normal (default).
- Mode 3 Commentator 2 ON AIR is permanently selected and cannot be disabled.

Commentator 2 TALKBACK A button:

- Mode 1 Commentator 2 TALKBACK A button momentary mode enabled (default).
- Mode 2 Commentator 2 TALKBACK A button latching mode enabled.
- Mode 3 Commentator 2 TALKBACK A button momentary and latching modes enabled.

Commentator 2 TALKBACK B button:

- Mode 1 Commentator 2 TALKBACK B button momentary mode enabled (default).
- Mode 2 Commentator 2 TALKBACK B button latching mode enabled.
- Mode 3 Commentator 2 TALKBACK B button momentary and latching modes enabled.

Commentator 3 ON AIR button:

- Mode 1 Commentator 3 ON AIR is permanently disabled and cannot be selected.
- Mode 2 Commentator 3 ON AIR can be selected as normal (default).
- Mode 3 Commentator 3 ON AIR is permanently selected and cannot be disabled.

Please note: Momentary mode button operation – press to activate, release to deactivate. Latching mode button operation – press once to activate, press again to deactivate.

Config Page 2 - Line Input Routing to Output

Commentator 1 ON AIR button:

- Mode 1 Commentator 3 line mode input is routed to Commentator 1 headphones (default).
- Mode 2 Commentator 3 line mode input is not routed to Commentator 1 headphones.

Commentator 1 TALKBACK A button:

No associated option on this page.

Commentator 1 TALKBACK B button:

No associated option on this page.

Commentator 2 ON AIR button:

- Mode 1 Commentator 3 line mode input is routed to Commentator 2 headphones (default).
- Mode 2 Commentator 3 line mode input is not routed to Commentator 2 headphones.

Commentator 2 TALKBACK A button:

No associated option on this page.

Commentator 2 TALKBACK B button:

No associated option on this page.

Commentator 3 ON AIR button:

No associated option on this page.

Config Page 3 - Commentator Mic & Line Input Routing to Headphones

Commentator 1 ON AIR button:

- Mode 1 Commentator 1 input permanently routed to Commentator 1 headphones.
- Mode 2 Commentator 1 input routed to Commentator 1 headphones only when Commentator 1 ON AIR is active (default).

Commentator 1 TALKBACK A button:

- Mode 1 Commentator 2 input permanently routed to Commentator 1 headphones.
- Mode 2 Commentator 2 input routed to Commentator 1 headphones only when Commentator 2 ON AIR is active (default).

Commentator 1 TALKBACK B button:

- Mode 1 Commentator 3 input permanently routed to Commentator 1 headphones.

Mode 2 Commentator 3 input routed to Commentator 1 headphones only when Commentator 3 ON AIR is active (default).

Commentator 2 ON AIR button:

Mode 1 Commentator 2 input permanently routed to Commentator 2 headphones.

Mode 2 Commentator 2 input routed to Commentator 2 headphones only when Commentator 2 ON AIR is active (default).

Commentator 2 TALKBACK A button:

Mode 1 Commentator 1 input permanently routed to Commentator 2 headphones.

Mode 2 Commentator 1 input routed to Commentator 2 headphones only when Commentator 1 ON AIR is active (default).

Commentator 2 TALKBACK B button:

Mode 1 Commentator 3 input permanently routed to Commentator 2 headphones.

Mode 2 Commentator 3 input routed to Commentator 2 headphones only when Commentator 3 ON AIR is active (default).

Commentator 3 ON AIR button:

No associated option on this page.

Config Page 4 – Miscellaneous

Commentator 1 ON AIR button:

Mode 1 GPIO port inputs drive TALKBACK call/alert signal (default).

Mode 2 GPIO port inputs control TALKBACK function.

Commentator 1 TALKBACK A button:

No associated option on this page.

Commentator 1 TALKBACK B button:

No associated option on this page.

Commentator 2 ON AIR button:

Mode 1 Temporary muting of enabled ON AIR channels is disabled (default).

Mode 2 Temporary muting of enabled ON AIR channels is enabled. For this setting to be available on a specific ON AIR channel, the corresponding Commentator ON AIR button option on Config Page 1 must be set to Mode 2, and the ON AIR LOCK must be enabled.

Commentator 2 TALKBACK A button:

No associated option on this page.

Commentator 2 TALKBACK B button:

No associated option on this page.

Commentator 3 ON AIR button:

Mode 1 Talkback cough mode using TALKBACK B buttons is disabled (default).

Mode 2 Talkback cough mode using TALKBACK B buttons is enabled. The two TALKBACK B buttons are ganged and they temporarily mute enabled ON AIR and TALKBACK A outputs for commentators 1 and 2 when active. The signals are also removed from the Mix Outputs. There is no audio routed to the TALKBACK B output in this mode and the TALKBACK GANG function on the rear panel is disabled.

Config Page 5 - Limit LED Colour & Limit/Power LED Brightness

Commentator 1 ON AIR button:

Mode 1 Limit indicator illuminates blue when active (default).

Mode 2 Limit indicator illuminates green when active.

Mode 3 Limit indicator illuminates red when active.

Mode 4 Limit indicator illuminates white when active. This setting can be used when a brighter limit indication is required.

Commentator 1 TALKBACK A button:
No associated option on this page.

Commentator 1 TALKBACK B button:
No associated option on this page.

Commentator 2 ON AIR button:

- Mode 1 Power and limit indicator brightness level 1 (minimum brightness).
- Mode 2 Power and limit indicator brightness level 2.
- Mode 3 Power and limit indicator brightness level 3 (default).
- Mode 4 Power and limit indicator brightness level 4.
- Mode 5 Power and limit indicator brightness level 5.
- Mode 6 Power and limit indicator brightness level 6.
- Mode 7 Power and limit indicator brightness level 7.
- Mode 8 Power and limit indicator brightness level 8 (maximum brightness).

Commentator 2 TALKBACK A button:
No associated option on this page.

Commentator 2 TALKBACK B button:
No associated option on this page.

Commentator 3 ON AIR button:
No associated option on this page.

Config Page 6 - ON AIR/TALKBACK Button & PPM Brightness

Commentator 1 ON AIR button:

- Mode 1 ON AIR and TALKBACK button brightness level 1 (minimum brightness).
- Mode 2 ON AIR and TALKBACK button brightness level 2.
- Mode 3 ON AIR and TALKBACK button brightness level 3.
- Mode 4 ON AIR and TALKBACK button brightness level 4.
- Mode 5 ON AIR and TALKBACK button brightness level 5.

- Mode 6 ON AIR and TALKBACK button brightness level 6.
- Mode 7 ON AIR and TALKBACK button brightness level 7 (maximum brightness) (default).

Commentator 1 TALKBACK A button:

No associated option on this page. This button illuminates green to indicate button brightness level.

Commentator 1 TALKBACK B button:

No associated option on this page. This button illuminates amber to indicate button brightness level.

Commentator 2 ON AIR button:

- Mode 1 PPM display brightness level 1 (minimum brightness).
- Mode 2 PPM display brightness level 2.
- Mode 3 PPM display brightness level 3.
- Mode 4 PPM display brightness level 4.
- Mode 5 PPM display brightness level 5 (default).
- Mode 6 PPM display brightness level 6.
- Mode 7 PPM display brightness level 7 (maximum brightness).
- Mode 8 PPM display disabled.

Commentator 2 TALKBACK A button:

No associated option on this page. This button illuminates amber to indicate button brightness level.

Commentator 2 TALKBACK B button:

No associated option on this page. This button illuminates green to indicate button brightness level.

Commentator 3 ON AIR button:

No associated option on this page. This button illuminates red to indicate button brightness level.

Config Page 7 - Save/Load Configurations & Firmware Version

The last page allows you to save the current option settings to either of two available backup sets that are unaffected by subsequent changes to the option settings. The backup sets can then be reloaded when required. The load/save functions will only work whilst in Page 7. Page 7 also shows the current firmware version by flashing the Limit LED in a recurring sequence i.e. 1 flash for version 1, 2 flashes for version2 etc.

To Save The Current Option Settings To Backup Set 1

Press and hold the Commentator 1 On Air and Talkback B buttons for 2 seconds. These buttons will then illuminate red to verify that the options have been saved to backup set 1.

To Save The Current Option Settings To Backup Set 2

Press and hold the Commentator 2 On Air and Talkback B buttons for 2 seconds. These buttons will then illuminate red to verify that the options have been saved to backup set 2.

To Load Backup Set 1 And Overwrite The Current Option Settings

Press and hold the Commentator 1 On Air and Talkback A buttons for 2 seconds. These buttons will then illuminate red to verify that backup set 1 has been loaded.

To Load Backup Set 2 And Overwrite The Current Option Settings

Press and hold the Commentator 2 On Air and Talkback A buttons for 2 seconds. These buttons will then illuminate red to verify that backup set 2 has been loaded.

To Exit Setup Mode

Press and hold the Commentator 1 and Commentator 2 On Air buttons for 3 seconds. When the power indicator stops flashing, the On Air buttons can be released and the unit will enter normal operating mode.

In addition to being able to load and save options, it is also possible to return the setup options to their factory default settings. Please note: all changes made to the options settings will be lost. Loading of the factory defaults does not affect the options stored in the backup sets.

To Return The Current Option Settings To Factory Defaults

Apply power to the unit whilst keeping Commentator 1 Talkback B and Commentator 2 Talkback A buttons pressed for 5 seconds. These buttons will then illuminate red to verify that the default options have been loaded. After the default options have been restored, the unit will return to normal operating mode.

CM-CU21 Technical Specification

Microphone Input

Gain Range:	+20dB to +86dB.
Maximum Input Level:	-6dBu.
Equivalent Input Noise:	130dB Ref. 80dB gain with 150Ω termination.
Equivalent Input Noise:	128dB Ref. 50dB gain with 150Ω termination.
C.M.R.R.:	>60dB.
Frequency Response:	±0.5dB 20Hz to 22kHz Ref 50dB gain @ 1kHz.

Electronically Balanced Line Input

Gain Range:	-83dB to +10dB.
Maximum Input Level:	+25dBu.
C.M.R.R.:	>70dB.
Frequency Response:	±0.2dB 20Hz to 22kHz Ref 0dB @ 1kHz.

Transformer Balanced Monitor Inputs

Gain Range:	-70dB to +7dB measured @ Headphone output.
Maximum Input Level:	+25dBu.
C.M.R.R.:	>60dB.
Frequency Response:	±0.5dB 20Hz to 22kHz Ref 0dB @ 1kHz.

Transformer Balanced Main Outputs

Maximum Output Level (limiter off):	+24dBu.
Frequency Response:	±0.5dB 20Hz to 22kHz Ref 0dB @ 1kHz.
Noise:	-94dB Average weighting Ref +8dB Line input.
THD & N:	<0.02% Ref. 1kHz @ +8dBu.
THD & N:	<0.065% Ref. 1kHz @ +18dBu.
1% Distortion Point:	+18dBu @ 24Hz.

Transformer Balanced Talkback Outputs

Maximum Output Level Limited:	+8dBu.
Frequency Response:	±0.5dB 20Hz to 22kHz Ref 0dB @ 1kHz.
Noise:	-94dB Average weighting Ref +8dB Line input.
THD & N:	<0.02% Ref. 1kHz @ +8dBu.
Gain Adjustment:	0-12dB

Electronically Balanced Comm Outputs

Maximum Output Level Limited:	+25dBu.
Frequency Response:	±0.2dB 20Hz to 22kHz Ref 0dB @ 1kHz.
Noise:	-98dB Average weighting Ref +8dB Line input.
THD & N:	<0.002% Ref. 1kHz @ +8dBu.

Headphone Outputs

Gain Range:	-66dB to +11dB.
Maximum Output Level:	+19dBu.
Frequency Response:	±0.5dB 20Hz to 22kHz Ref 0dB @ 1kHz.
Noise:	-85dB Average weighting Ref +8dB Line input.
THD & N:	<0.005% Ref. 1kHz @ +8dBu.

Main Panel Operational Controls & Indicators

On-Air 1-3 Buttons:	Illuminated buttons with latching action
Talkback A & B Buttons:	Illuminated buttons with selectable momentary and/or latching action
Headphone Monitor Controls:	Input source level adjustment potentiometers Headphone channel selection switches
Line Input Level:	Guest line input mode level potentiometer

PPM Meter:	21 segment display showing mix output level, brightness level is selectable
Limit LED:	Indicates main output limiter is active, colour & brightness level is selectable
Power LED:	Indicates operating mode; normal or setup

Front Panel Operational Controls

Phantom:	Switch to enable 48V microphone phantom power for positions 1 & 2
Mic Gain:	Microphone gain potentiometer and range select switch selects +20dB to +56dB or +50 to +86dB

Rear Panel Operational Controls

On Air Lock:	Switch to prevent On Air control from being deactivated Momentary push-button to override On Air lock
T/B Gang:	Switch to link operation of talkbacks A & B
T/B Gain:	0dB to +12dB
Limiter:	Switch to enable limiter on mix output Limit level adjustment potentiometer
Test Tone:	Switch to enable 1 kHz line-up tone

Configuration Options – Accessible via Setup Mode

On Air Control Mode:	Disabled, normal or permanently on
Talkback Button Action:	Momentary, latching or both
Headphone Routing:	Commentator inputs 1-3 permanently routed to Commentator 1-2 headphones Commentator inputs 1-3 permanently routed to Commentator 1-2 headphones when respective input is On Air

Display Preferences:	Limit LED colour and brightness Button LED brightness PPM meter LED brightness/disable
Permanent Option Backup:	Save/load options to/from Permanent backup or return to factory defaults

Connections

Headphone Outputs:	3 x 1/4" (6.35mm) A/B gauge 3-pole stereo jack socket - locking for positions 1 and 2.
Microphone/Line Inputs:	3 x XLR-3 pin female latching (electronic balanced).
Return Audio Inputs (Prog, A, B & C):	4 x XLR-3 pin female latching (transformer balanced).
Commentator Outputs (Comm1-3):	3 x XLR-3 pin male (electronic balanced).
Talkback A & B Outputs:	2 x XLR-3 pin male (transformer balanced).
Mix 1 & 2 Outputs:	2 x XLR-3 pin male (transformer balanced).
GPIO Port:	15-way 'D'-type socket.
Mains Input:	Universal filtered IEC, continuously rated 85-264VAC, 47-63Hz, 10W.
Fuse Rating:	Anti-surge fuse 1A 20 x 5mm.
DC Input:	XLR-4 pin male. 12V DC, 650mA Typical, 850mA Maximum. 24V DC, 325mA Typical, 425mA Maximum.
Earth Point:	M4 stud.

Dimensions

Dimensions:	270mm (W) x 230mm (D) x 70mm (H - front) x 95mm (H - rear) 10.6" (W) x 9" (D) x 2.8" (H - front) x 3.74" (H - rear)
-------------	--

3 Accessories

Weight:	Nett: 3.34kg	Gross: 4.32kg
	Nett: 7.35lbs	Gross: 9.5lbs

Accessories

CM-CU21CP	Commentator Unit Front Cover Plate
-----------	------------------------------------

CM-CU21TP	Commentator Unit Transport Case
-----------	---------------------------------

Dimensions (Raw):	530mm (W) x 210mm (D) x 415mm (H)
(CM-CU21TP)	20.9" (W) x 8.3" (D) x 16.3" (H)

Dimensions (Boxed):	600mm (W) x 260 (D) x 420 (H)
(CM-CU21TP)	23.6" (W) x 10.2" (D) x 16.5" (H)

Weight:	Net: 4.0kg	Gross: 5.0kg
(CM-CU21TP)	Net: 8.8lbs	Gross: 11.0lbs

Accessories

Transport Case

For both the CM-CU1 and CM-CU21 there is a transport case, (CM-CU21TP), which is supplied empty. The illustrations below show the case empty (Fig 3-1a), and also with a commentator unit and accessories inside, (Fig 3-1b).



Fig 3-1a: CM-CU21TP Commentator Unit Transport Case (empty)



Fig 3-1b: CM-CU21TP Commentator Unit Transport Case (filled)

Accessories *continued...*

Commentator Front Cover Plate

For the CM-CU21 there is a front cover plate (CM-CU21CP) which is used to cover the adjustments available on the front of the CM-CU21 commentator unit with the exception of the MIC INPUT 1, jack socket, MIC/LINE INPUT and the MIC INPUT 2.



Fig 3-2: CM-CU21CP Commentator Unit Front Cover Plate

SONIFEX

www.sonifex.co.uk

t:+44 (0)1933 650 700

f:+44 (0)1933 650 726

sales@sonifex.co.uk