



CM-BHA Beltpack
Headphone Amplifier with
Limiter & Loudspeaker
User Handbook





CM-BHA HANDBOOK



CM-BHA HANDBOOK

This handbook is for use with the following product:
CM-BHA Belt Pack Headphone Amplifier with Limiter & Loudspeaker.

©Sonifex Ltd, 2013
All Rights Reserved
Revision 1.00, November 2013

Sonifex Ltd, 61, Station Road, Irthlingborough,
Northants, NN9 5QE, England.
Tel: +44 (0)1933 650 700
Fax: +44 (0)1933 650 726
Email: sales@sonifex.co.uk
Website: <http://www.sonifex.co.uk>

Information in this document is subject to change without notice and does not represent a commitment on the part of the vendor. Sonifex Ltd shall not be liable for any loss or damage whatsoever arising from the use of information or any error contained in this manual.

No part of this manual may be reproduced or transmitted in any form or by any means, electronic or mechanical, including photocopying, recording, information storage and retrieval systems, for any purpose other than the purchaser's personal use, without the express written permission of Sonifex Ltd. Unless otherwise noted, all names of companies, products and persons contained herein are part of a completely fictitious adaptation and are designed solely to document the use of Sonifex product.

Made in the UK by **SONIFEX**



Warranty	i
Warranty and Liability	i
Unpacking the Passive Digital Splitters	iii
Returning the Warranty Card	iii
Installation Information	iv
Atmosphere	iv
WEEE & RoHS Directives - Sonifex Statement	iv
1. CM-BHA Belt Pack Headphone Amplifier	1
Introduction	1
2 Top Panel Controls & Indicators	2
Headphone/Earpiece Socket	2
Gain/Volume Control	2
Low Battery Indicator	2
Limit Level Control and Indicator	2
3 Side Panel Controls	2
Limiter On/Off Switch	3
4 Bottom Panel Connections	3
Loop Through	3
5 Technical Specification For CM-BHA Belt Pack Headphone Amplifier	4



CONTENTS

CONTENTS & FIGURES

Figures

Fig A: Packing List	iii
Fig 1-1: CM-BHA Belt Pack Headphone Amplifier	1
Fig 1-2: CM-BHA Block Diagram	1
Fig 2-1: Top Panel View of CM-BHA	2
Fig 3-1: Side Panel View of CM-BHA	2
Fig 3-2: Bottom Panel View of CM-BHA	3

FIGURES



Warranty

Warranty and Liability

Important: the purchaser is advised to read this clause

- (a) The Company agrees to repair or (at its discretion) replace Goods which are found to be defective (fair wear and tear excepted) and which are returned to the Company within 12 months of the date of despatch provided that each of the following are satisfied:
 - (i) notification of any defect is given to the Company immediately upon its becoming apparent to the Purchaser;
 - (ii) the Goods have only been operated under normal operating conditions and have only been subject to normal use (and in particular the Goods must have been correctly connected and must not have been subject to high voltage or to ionising radiation and must not have been used contrary to the Company's technical recommendations);
 - (iii) the Goods are returned to the Company's premises at the Purchaser's expense;
 - (iv) any Goods or parts of Goods replaced shall become the property of the Company;
 - (v) no work whatsoever (other than normal and proper maintenance) has been carried out to the Goods or any part of the Goods without the Company's prior written consent;
 - (vi) the defect has not arisen from a design made, furnished or specified by the Purchaser;
 - (vii) the Goods have been assembled or incorporated into other goods only in accordance with any instructions issued by the Company;
 - (viii) the defect has not arisen from a design modified by the Purchaser;
 - (ix) the defect has not arisen from an item manufactured by a person other than the Company.

In respect of any item manufactured by a person other than the Company, the Purchaser shall only be entitled to the benefit of any warranty or guarantee provided by such manufacturer to the Company.

- (b) In respect of computer software supplied by the Company the Company does not warrant that the use of the software will be uninterrupted or error free.
- (c) The Company accepts liability:
 - (i) for death or personal injury to the extent that it results from the negligence of the Company, its employees (whilst in the course of their employment) or its agents (in the course of the agency);



WARRANTY



WARRANTY

- (ii) for any breach by the Company of any statutory undertaking as to title, quiet possession and freedom from encumbrance.
- (d) Subject to conditions (a) and (c) from the time of despatch of the Goods from the Company's premises the Purchaser shall be responsible for any defect in the Goods or loss, damage, nuisance or interference whatsoever consequential economic or otherwise or wastage of material resulting from or caused by or to the Goods. In particular the Company shall not be liable for any loss of profits or other economic losses. The Company accordingly excludes all liability for the same.
- (e) At the request and expense of the Purchaser the Company will test the Goods to ascertain performance levels and provide a report of the results of that test. The report will be accurate at the time of the test, to the best of the belief and knowledge of the Company, and the Company accepts no liability in respect of its accuracy beyond that set out in Condition (a).
- (f) Subject to Condition (e) no representation, condition, warranty or other term, express or implied (by statute or otherwise) is given by the Company that the Goods are of any particular quality or standard or will enable the Purchaser to attain any particular performance or result, or will be suitable for any particular purpose or use under specific conditions or will provide any particular capacity, notwithstanding that the requirement for such performance, result or capacity or that such particular purpose or conditions may have been known (or ought to have been known) to the Company, its employees or agents.
- (g)
 - (i) To the extent that the Company is held legally liable to the Purchaser for any single breach of contract, tort, representation or other act or default, the Company's liability for the same shall not exceed the Price of the Goods.
 - (ii) The restriction of liability in Condition (g)(i) shall not apply to any liability accepted by the Seller in Condition (c).
- (h) Where the Goods are sold under a consumer transaction (as defined by the Consumer Transactions (Restrictions on Statements) Order 1976) the statutory rights of the Purchaser are not affected by these Conditions of Sale.



Unpacking the CM-BHA

The CM-BHA is shipped with the following equipment. Please check your packaging to ensure that you have all of the items below. If anything is missing, please contact the supplier of your equipment immediately.

Item	Quantity
CM-BHA	1
Handbook and warranty card	1

Fig A: Packing List

The CM-BHA is shipped in protective packaging and should be inspected for damage before use. Where an item is found to have transit damage, notify the carrier immediately with all the relevant details of the shipment. Packing materials should be kept for inspection and also for if the product needs to be returned.

Returning the Warranty Card

In order to register the date of purchase so that we can keep you informed of any design improvements or modifications, it is important to complete the warranty registration document that is enclosed and return it to Sonifex Ltd in the UK, or register online at www.sonifex.co.uk/register

For your own records you should write down the serial number (which can be found on the rear of the CM-BHA).

Serial Number
---------------	-------



WARRANTY

WEEE & ROHS DIRECTIVE

Installation Information

Atmosphere

The units should be installed in an area that is not subject to excessive temperature variation (<0°C, >50°C), moisture, dust or vibration.

WEEE & RoHS Directives - Sonifex Statement



The Waste Electrical and Electronic Equipment (WEEE) Directive was agreed on 13 February 2003, along with the related Directive 2002/95/EC on Restrictions of the use of certain Hazardous Substances in electrical and electronic equipment (RoHS).

The **Waste Electrical and Electronic Equipment Directive (WEEE)** aims to minimise the impacts of electrical and electronic equipment on the environment during their life times and when they become waste. It applies to a huge spectrum of products. It encourages and sets criteria for the collection, treatment, recycling and recovery of waste electrical and electronic equipment. All products manufactured by Sonifex Ltd have the WEEE directive label placed on the case. It gives a contact for individuals who are unsure about the correct procedure when the product has reached its "end of use".

Sonifex Ltd will be happy to give you information about local organisations that can reprocess the products, or alternatively all products that have reached "end of use" can be returned to Sonifex and will be reprocessed correctly free of charge.

Sonifex Ltd has phased out the use of certain hazardous substances identified in the European Union's **Restriction of Hazardous Substances (RoHS)** directive. The RoHS directive limits the use of certain hazardous substances currently used in EEE manufacture, including lead, mercury, cadmium, hexavalent chromium, and halide-containing compounds PBB (polybrominated biphenyl) and PBDE (polybrominated diphenyl ether). Elimination of these substances will result in more environmentally friendly recycling of electronic equipment. For the products which Sonifex manufacture, the main area where products were affected was in the use of lead for manufacturing and assembling electronics circuit boards.

Sonifex Ltd practices lead-free (LF) manufacturing processes. LF solder is used on the surface-mount PCB manufacturing processes and for hand soldering. The printed circuit boards (PCBs) used are either gold plated, or immersion tin plated, both of which use no lead. Historically the PCBs were hot air solder levelled (HASL) PCBs which used tin/lead based solder.

The manufacturing processes include the assembly of purchased components from various sources. Product is offered as RoHS compliant, or LF, only after sufficient evidence is received from the component manufacturers that their components are RoHS compliant. Sonifex Ltd relies solely on the distributor, or manufacturer, of the components for identification of RoHS compliance. Thus whilst every effort is made to ensure compliance, Sonifex Ltd makes no warranty, or certification, or declaration of compliance concerning said components.

Sonifex Ltd defines "Lead Free" as pertaining to any product, which has been manufactured by Sonifex Ltd using components which have been declared by the manufacturers as "Lead Free". All statements by Sonifex Ltd of RoHS compliance are based on component manufacturer documentation.

1. CM-BHA Belt Pack Headphone Amplifier

Introduction



Fig 1-1: CM-BHA Belt Pack Headphone Amplifier

The CM-BHA is a portable, battery powered headphone amplifier for use in live applications such as in-the-field news reports, providing audio feed monitoring by headphones, earpiece, or built-in speaker.

Up to +20dB of gain can be applied to the incoming signal. The volume control simultaneously modifies the output volume and the input gain, allowing input signals in excess of +24dBu to be reproduced without distortion.

An adjustable limiter protects the listener from excessive levels. The limiter is only enabled when an earpiece or headphones are used, and when it is enabled by the toggle switch. It is disabled when no jack is inserted, allowing a higher volume to be passed to the speaker for “squawk mode” use.

A low battery warning LED flashes when the 9V PP3 battery has depleted to 6V, giving plenty of notice to swap the battery. The low power circuitry of the CM-BHA gives up to 200 hours use from a single alkaline 9V PP3 battery.

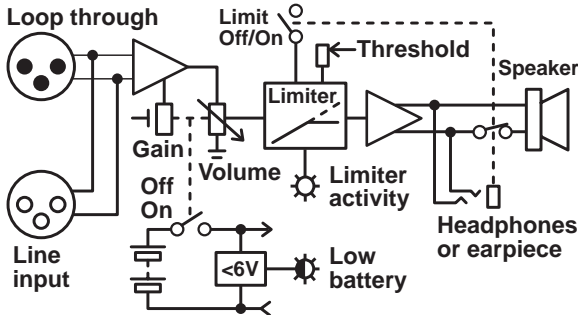

Fig 1-2: CM-BHA Block Diagram

2 CM-BHA CONTROLS & INDICATORS



CM-BHA CONTROLS & INDICATORS

2 Top Panel Controls & Indicators



Fig 2-1: Top Panel View of CM-BHA

Headphone/Earpiece Socket

The headphone/earpiece connector is a 1/4" jack socket that provides a differential signal to a mono earpiece, or to stereo headphones. When using stereo headphones, the right ear will be anti-phase, however speech will be perfectly discernible.

Gain/Volume Control

The gain/volume control simultaneously modifies input gain and output volume, allowing the user to connect high level signals (up-to +24dBu) without distorting.

Low Battery Indicator

Should the battery voltage fall below 6V, the 3mm red low battery indicator will flash, warning the user that the battery should be changed as soon as possible to prevent failure.

Limit Level Control and Indicator

The output level limiter (when enabled) prevents large signals from damaging the user's ears. The limit level is adjusted between -6dBu and +6dBu using the recessed potentiometer, and limiter activity is indicated by a blue LED. Persistent illumination informs the user that the volume should be reduced.

3 Side Panel Controls



Fig 3-1: Side Panel View of CM-BHA

Limiter On/Off Switch

The output level limiter is enabled/disabled using the toggle switch on the side panel. The limiter is disabled when the built-in speaker is active.

4 Bottom Panel Connections



Fig 3-2: Bottom Panel View of CM-BHA

The audio connections are found on the bottom panel, and both have the following connections:

Pin 1: Ground

Pin 2: Phase

Pin 3: Non-phase

Line Input

The line input is an electronically balanced audio input with 200k Ω input impedance, allowing multiple units to be daisy-chained together, without causing noticeable loss of signal level. The line input can accept input levels of upto +24dBu.

Loop Through

The loop through is a non-driven, parallel connection of the line input, allowing multiple units to be daisy-chained together without specialist audio cables.



5 Technical Specification For CM-BHA Belt Pack Headphone Amplifier

Line Input Impedance:	200k Ω Electronically Balanced	
Input Liiter Threshold:	Adjustable -6Bu to +6dBu	
Maximum Input Level:	+24dBu	
Input Gain/Volume:	Adjustable -70dB to +20dB	
Frequency Response:	\pm 0.5dB (ref 0dBu 1kHz)	
Noise:	<-75dBu A-weighted (ref 0dB gain)	
Distortion:	<0.015% (ref +8dBu input, 0dB gain, 10k Ω load)	
Maximum HP Output Level:	+16dBu (ref 9V battery voltage, <1% THD, 2k Ω load) +12dBu (ref 6V battery voltage, <1% THD, 2k Ω load)	
Minimum HP impedance:	32 Ω	
Maximum Speaker Level:	+12dBu (ref 9V battery voltage, <1% THD) +6dBu (ref 6V battery voltage, <1% THD)	
Dimensions (Raw):	12.5cm (W) x 6.7cm (D) x 4.8cm (H) 4.9" (W) x 2.6" (D) x 1.9" (H)	
Dimensions (Boxed):	23cm (W) x 13cm (D) x 8cm (H) 9.1" (W) x 5.1" (D) x 3.1" (H)	
Weight:	Nett: 0.3kg	Gross: 0.4kg
	Nett: 0.7lbs	Gross: 0.9lbs



NOTES



NOTES



NOTES

SONIFEX

www.sonifex.co.uk

t:+44 (0)1933 650 700

f:+44 (0)1933 650 726

sales@sonifex.co.uk

